

LOC/DME I-GSP <b>109.3</b> Chan <b>30</b>	APP CRS <b>038°</b>	Rwy Idg <b>11001</b> TDZE <b>947</b> Apt Elev <b>964</b>
---	------------------------	--

# ILS RWY 4 (SA CAT I)

GREENVILLE SPARTANBURG INTL (GSP)

DME required.			ALSF-2		
Requires specific OPSPEC, MSPEC, or LOA approval and use of HUD to DH. Procedure NA when control tower closed.			MISSED APPROACH: Climb to 3000 then right turn direct SPA VORTAC and hold.		
ATIS <b>134.25</b>	GREER APP CON* <b>118.8 270.275</b>	GREER TOWER* <b>120.1(CTAF) 251.15</b>	GND CON <b>121.9</b>	CLNC DEL <b>121.9</b>	UNICOM <b>122.95</b>

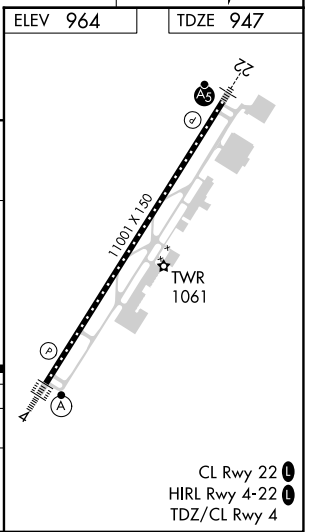
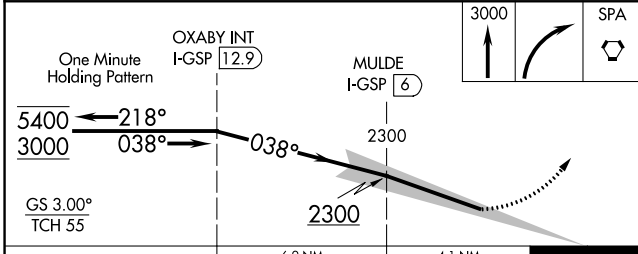
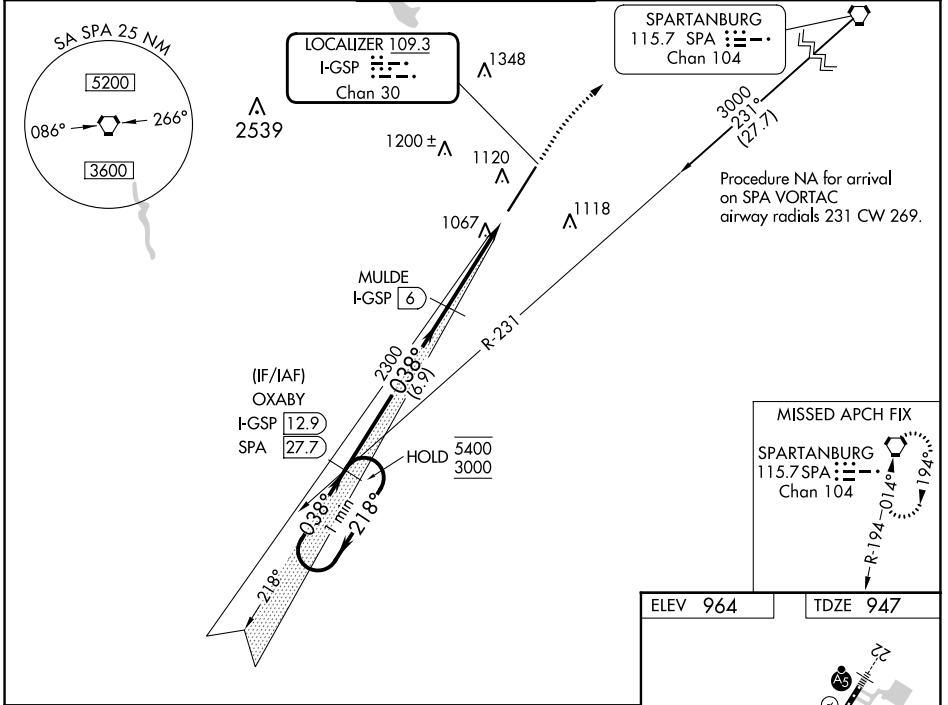

CATEGORY	A	B	C	D
S-ILS 4	RA 258/14 150 DA 1097			

**SA CATEGORY I ILS - SPECIAL AIRCREW & AIRCRAFT CERTIFICATION REQUIRED**

SE-2, 05 SEP 2024 to 03 OCT 2024

SE-2, 05 SEP 2024 to 03 OCT 2024