

WAAS CH 40233 W25A	APP CRS 251°	Rwy Idg TDZE Apt Elev	3268 840 840
--	------------------------	-----------------------------	---

RNAV (GPS) RWY 25

AKRON/JESSON FLD (9G3)

RNP APCH.	MISSED APPROACH: Climbing left turn to 4000 direct IGRUH and hold, continue climb-in-hold to 4000.
<p>▼ Rwy 25 helicopter visibility reduction below 1 SM NA.</p> <p>▲ NA Use Buffalo altimeter setting. Procedure NA at night.</p>	

BUF ASOS 135.35	BUFFALO APP CON 126.15 263.125	UNICOM 122.725 (CTAF)
---------------------------	--	---------------------------------

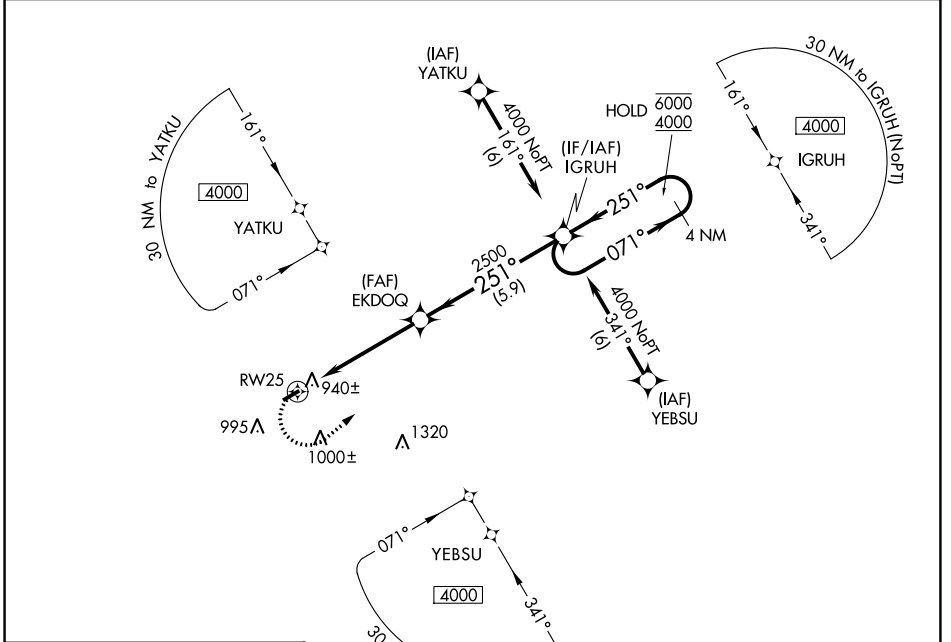

NE-2, 05 SEP 2024 to 03 OCT 2024

NE-2, 05 SEP 2024 to 03 OCT 2024

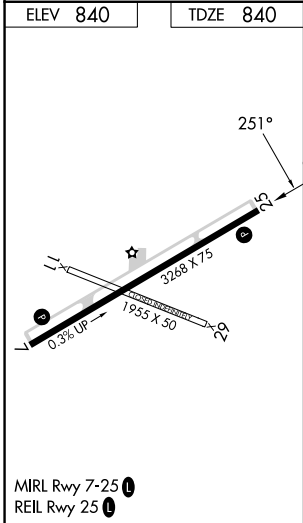

<p>▲ 2448</p> <p>4000 IGRUH Visual Segment - Obstacles.</p>	4 NM Holding Pattern			
	<p>IGRUH</p> <p>EKDOQ</p> <p>RW25</p> <p>2500</p> <p>5.1 NM 5.9 NM</p> <p>071° → 6000</p> <p>← 251° 4000</p>			
CATEGORY	A	B	C	D
LP MDA	1240-1	400 (400-1)	NA	
LNAV MDA	1300-1	460 (500-1)	NA	
CIRCLING	1380-1	540 (600-1)	NA	