

WAAS CH 86438 W32A	APP CRS 324°	Rwy Ldg TDZE 4546 Apt Elev 4595
----------------------------------------	------------------------	-----------------------------------------------------

RNAV (GPS) RWY 32

FORT MORGAN MUNI (FMM)

⚠ DME/DME RNP-0.3 NA. When local altimeter setting not received, use Akron altimeter setting: increase all DA to 4879 feet and all visibilities 1/8 mile; increase all MDA 100 feet and all Cat C and D visibilities 1/4 mile. Night landing: Rwy 8, 17, 26, 32, 35 NA. Helicopter visibility reduction below 1 SM NA.

MISSED APPROACH:
Climb to 7400 direct ECUDI and hold.

AWOS-3PT 132.95	DENVER CENTER 118.475 225.4	UNICOM 123.05 (CTAF) 0
---------------------------	---------------------------------------	----------------------------------

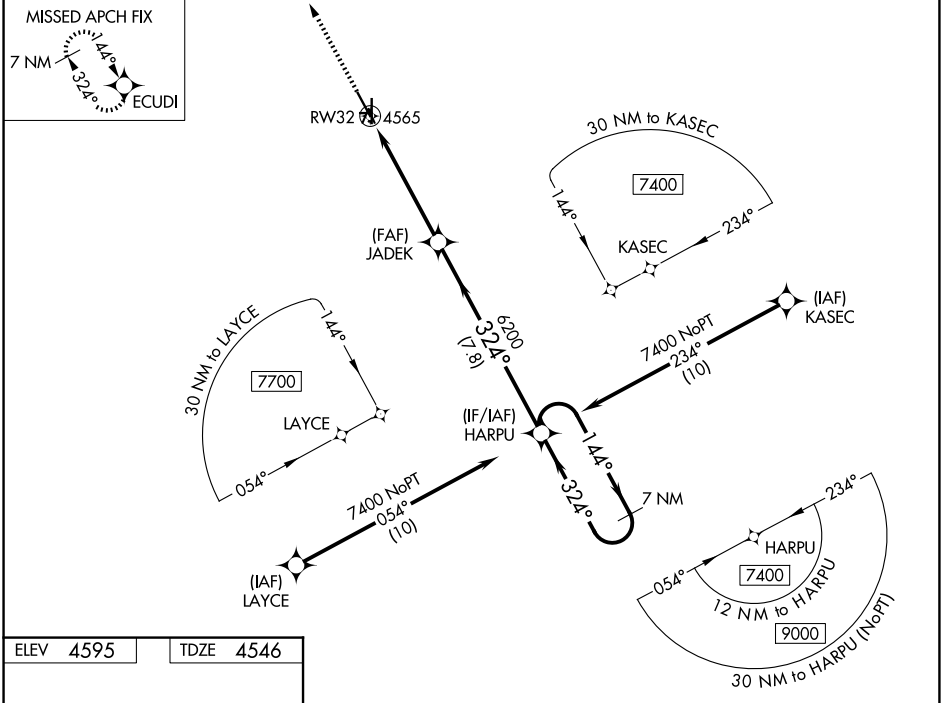

ELEV 4595	TDZE 4546
------------------	------------------

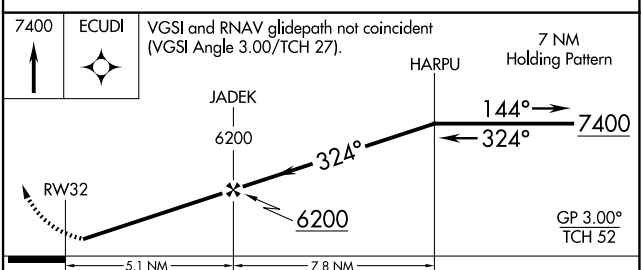
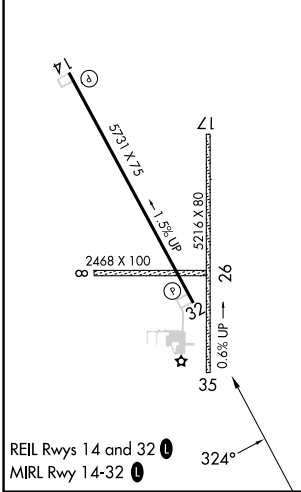

CATEGORY	A	B	C	D
LPV DA		4796-1	250 (300-1)	
LNAV/VNAV DA		4796-1	250 (300-1)	
LNAV MDA		4820-1	274 (300-1)	
CIRCLING	5040-1 445 (500-1)	5080-1 485 (500-1)	5120-1½ 525 (600-1½)	5340-2½ 745 (800-2½)

SW-1, 30 OCT 2025 to 27 NOV 2025

SW-1, 30 OCT 2025 to 27 NOV 2025