

LOC I-IWD 111.5	APP CRS 270°	Rwy Ldg 6501
		TDZE 1230
		Apt Elev 1230

ILS or LOC RWY 27

GOGEBIC/IRON COUNTY (IWD)

When local altimeter setting not received, use ASX altimeter setting: increase DA to 1562 feet; increase all MDAs 140 feet and S-LOC 27 visibility Cats C and D 1/2 SM and Circling visibility Cat B 1/4 SM. For inop ALS when using ASX altimeter setting, increase S-ILS 27 all Cats visibility to 1 SM.

NA
-26°C

MALSR
AS

MISSED APPROACH:
Climb to 3300 then right turn direct IWD VOR/DME and hold.

AWOS-3PT 125.175	MINNEAPOLIS CENTER 133.55	UNICOM 122.8 (CTAF)
----------------------------	-------------------------------------	-------------------------------

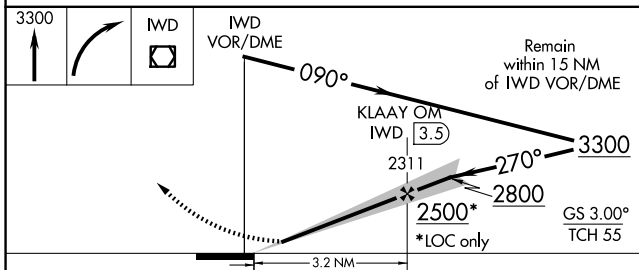
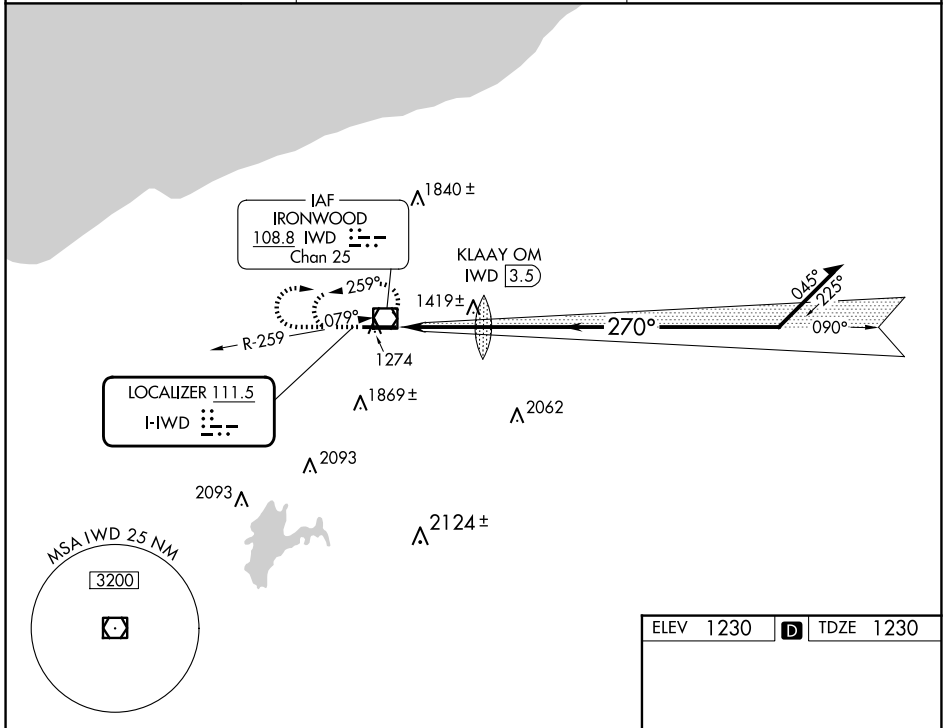

ELEV 1230	D	TDZE 1230
-----------	---	-----------

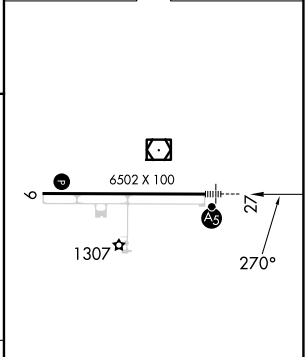

CATEGORY	A	B	C	D
S-ILS 27		1430-1/2	200 (200-1/2)	
S-LOC 27	1720-1/2	490 (500-1/2)	1720-1	490 (500-1)
CIRCLING	2100-1/4	870 (900-1/4)	2200-3 970 (1000-3)	2220-3 990 (1000-3)

REIL Rwy 9

HIRL Rwy 9-27

FAF to MAP 3.2 NM

Knots	60	90	120	150	180
Min:Sec	3:12	2:08	1:36	1:17	1:04

EC-1, 16 APR 2026 to 14 MAY 2026

EC-1, 16 APR 2026 to 14 MAY 2026