

# ICONS FIVE DEPARTURE (RNAV)

MID-CAROLINA RGNL (RUQ)  
SALISBURY, NORTH CAROLINA

CHARLOTTE DEP CON  
128.325 307.8  
AWOS-3  
118.175  
CLNC DEL  
127.35  
UNICOM  
122.725

RNAV - 1 DME/DME/IRU or GPS.

RADAR required.

**TOP ALTITUDE:  
3000**

### TAKEOFF MINIMUMS

Rwy 2: Standard.

Rwy 20: 400-2<sup>3</sup>/<sub>4</sub> or standard with minimum climb of 205' per NM to 1300, or alternatively, with standard takeoff minimums and a normal 200' per NM climb gradient, takeoff must occur no later than 1200' prior to DER.

- NOTE: For turbo jets only.
- NOTE: If unable to accept climb rates, advise ATC on initial contact.
- NOTE: Transponder code will be issued via PDC or Charlotte CLNC DEL.
- NOTE: Upon reaching 10000 MSL, accelerate to and maintain 280K, if unable advise ATC.

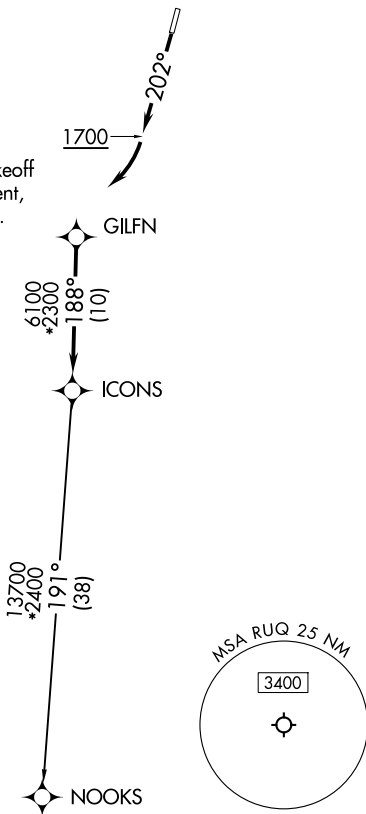

NOTE: Chart not to scale.



### DEPARTURE ROUTE DESCRIPTION

TAKEOFF RUNWAY 2: Climb on heading assigned by ATC, thence. . . .

TAKEOFF RUNWAY 20: Climb on heading 202° to 1700 before turning right, then on heading assigned by ATC, thence. . . .

. . . .on RADAR vectors to GILFN, then on track 188° to ICONS. Then on NOOKS Transition. Maintain 3000, expect filed altitude within 10 minutes after departure.

NOOKS TRANSITION (ICONS5.NOOKS)

# ICONS FIVE DEPARTURE (RNAV)