



**Federal Aviation
Administration**

UNITED STATES GOVERNMENT SPECIFICATIONS

**FLIGHT INFORMATION PUBLICATION
STANDARD TERMINAL ARRIVAL (STAR)
CHARTS**

IAC 14
25 April 2026

Prepared by the Interagency Air Committee (IAC)

**UNITED STATES GOVERNMENT SPECIFICATIONS
FOR THE
FLIGHT INFORMATION PUBLICATION
STANDARD TERMINAL ARRIVAL (STAR) CHARTS**

25 April 2026

These specifications have been developed by the Interagency Air Committee (IAC), composed of representatives of the Department of Defense and the Federal Aviation Administration, for use in the preparation of the United States Government Flight Information Publication Standard Terminal Arrival (STAR) Charts. These specifications shall be complied with, without deviation, until such time as they are amended by formal IAC action.

Changes to these specifications will be provided when necessitated by new requirements or through development action of the IAC.

Questions of interpretation that arise in the use of these specifications shall be referred to the Chair, Interagency Air Committee.

Page Intentionally Left Blank

CHANGES APPLIED TO CURRENT EDITION

REQUIREMENT DOCUMENTS

- a. RD 902 - Communication Data on Departure Procedures (DPs) and Standard Terminal Arrival (STAR) Charts

EDITORIAL CHANGES

- a. None applied this edition.

CHANGES APPLIED 7 OCTOBER 2025

REQUIREMENT DOCUMENTS

- a. RD 899 - Documenting DoD Exceptions and Differences to IAC Specifications

EDITORIAL CHANGES

- a. None applied this edition.

CHANGES APPLIED 18 SEPTEMBER 2025

REQUIREMENT DOCUMENTS

- a. None applied this edition.

EDITORIAL CHANGES

- a. EC 25-10 Localizer Fans on RNAV DPs and STARs
- b. EC 25-11 Transition Text Location on STARs
- c. EC 25-12 Part-Time Frequency Depiction in TPP

CHANGES APPLIED 10 JULY 2025

REQUIREMENT DOCUMENTS

- a. None applied this edition.

EDITORIAL CHANGES

- a. EC 25-02 Clarification of DP & STAR Communications

CHANGES APPLIED 6 MAY 2025

REQUIREMENT DOCUMENTS

- a. RD 889 - Airport Location Identifiers on Terminal Chart Products

EDITORIAL CHANGES

- a. None applied this edition.

CHANGES APPLIED 4 SEPTEMBER 2024

REQUIREMENT DOCUMENTS

- a. None applied to this edition.

EDITORIAL CHANGES

- a. EC 24-05 NAVAID Leaders on RNAV Charts

AMENDMENT OF SPECIFICATIONS

1. PROCEDURE

- a. Recommendations for amendments to specifications from the Department of Defense shall be directed to:

National Geospatial-Intelligence Agency
7500 GEOINT Drive
Springfield, VA 22150-7500

- b. Recommendations for amendments to specifications from the Federal Aviation Administration shall be directed to:

Federal Aviation Administration /
Aeronautical Information Services
SSMC-4 Sta # 4445
1305 East-West Highway
Silver Spring, MD 20910

2. AMENDMENT SYSTEM

- a. Change to the specifications will be issued at the effective date of the latest Requirement Document (RD) and / or Editorial Change (EC).
- b. The Specification will be dated, indicated along the upper margin of each page, to reflect the most current change.

Page Intentionally Left Blank

TABLE OF CONTENTS

CHAPTER 1 – GENERAL

1.1 PURPOSE AND SCOPE..... 1-1

 1.1.1 Purpose 1-1

 1.1.2 Scope 1-1

1.2 REQUIREMENTS 1-1

 1.2.1 General 1-1

 1.2.2 Quality and Accuracy 1-1

 1.2.3 Color 1-1

 1.2.4 Scale 1-1

 1.2.5 Projection..... 1-1

 1.2.6 Horizontal Reference 1-2

 1.2.7 Symbolization..... 1-2

 1.2.8 Type Styles 1-2

 1.2.9 Department of Defense (DoD) Exceptions and Differences 1-2

 Figure 1.1 DoD Exception 1-2

1.3 SPECIFICATION APPENDICES..... 1-2

CHAPTER 2 – FORMAT AND LAYOUT

2.1 Format..... 2-1

 Figure 2.1 North Arrow..... 2-1

2.2 Layout 2-1

CHAPTER 3 – CONTENT

3.1 GENERAL..... 3-1

3.2 COMPILATION..... 3-1

 3.2.1 Relative Positioning..... 3-1

 3.2.2 Scale 3-1

 Figure 3.1 Chart Not to Scale Note 3-1

 3.2.3 Displacement 3-1

 3.2.4 Alignment 3-1

 3.2.5 Placement of Identification and Notes 3-1

3.3 MARGIN DATA..... 3-2

 Figure 3.2 Margin Information - Single Airport (Top and Bottom) 3-2

 Figure 3.3 Margin Information - Area STAR (Top and Bottom) 3-2

3.3.1	Procedural Designation.....	3-2
3.3.1.1	Multipage Graphics.....	3-2
3.3.2	Julian Date	3-3
3.3.3	Procedure Effective Date.....	3-3
3.3.4	Chart Reference Number	3-3
3.3.5	Airport Name and Identifier	3-3
3.3.6	Location	3-3
3.4	Plan View.....	3-3
3.4.1	General.....	3-3
	Figure 3.4 Lightning Leader	3-4
3.4.2	Communications	3-4
3.4.2.1	General	3-4
3.4.2.2	Standard Communications	3-4
3.4.2.2.1	Approach Control (APP CON).....	3-5
3.4.2.2.2	Automatic Terminal Information Service (ATIS)	3-5
3.4.2.2.3	(AK) Automated Flight Information Service (AFIS)	3-5
3.4.2.2.4	Area STAR Communications	3-5
	Figure 3.5 Area STAR Communications.....	3-5
3.4.2.2.5	Hours of Operation	3-5
	Figure 3.6 Part-time Operation Depiction	3-5
3.4.2.3	Additional Communications	3-6
3.4.2.4	Automated Weather Systems (ASOS/AWOS)	3-6
3.4.3	Fly-over Symbology	3-6
3.4.4	Compulsory Reporting Points	3-6
3.4.5	Airports.....	3-6
3.4.6	Radio Aids to Navigation (NAVAIDs)	3-7
3.4.6.1	General	3-7
3.4.6.2	Frequencies Without Voice.....	3-7
3.4.6.3	Symbolization and Identification of NAVAIDS.....	3-7
	Figure 3.7 NAVAID Symbolization.....	3-7
3.4.6.3.1	Frequency Protection Range (T).....	3-7
3.4.6.3.2	Leader Lines	3-7
3.4.6.3.3	Line Weight	3-8
3.4.6.3.4	NAVAID Boxes.....	3-8
3.4.6.4	“Y” Mode NAVAIDs.....	3-8
3.4.6.5	Instrument Landing System (ILS) Localizer Course	3-8
	Figure 3.8 ILS Localizer Course	3-8

- 3.4.6.5.1 Localizers on RNAV STARs..... 3-8
 - Figure 3.9 Localizer on RNAV STAR.....3-8
- 3.4.7 RNAV STARs 3-9
 - 3.4.7.1 NAVAIDs 3-9
 - 3.4.7.2 Leg Types..... 3-9
 - Table 3.1 Leg Types3-9
 - Figure 3.10 Waypoint Depiction.....3-9
- 3.4.8 Named DME Fixes, Unnamed DME Fixes, Intersections, Computer Navigation Fixes (CNF) and Waypoints 3-10
 - 3.4.8.1 General 3-10
 - 3.4.8.2 Named DME Fixes..... 3-10
 - Figure 3.11 Named DME Fix.....3-10
 - 3.4.8.3 Unnamed DME 3-10
 - Figure 3.12 Unnamed DME Fix.....3-10
 - Figure 3.13 Unnamed DME Fix with Colocated CNF3-11
 - 3.4.8.4 Intersections 3-11
 - Figure 3.14 Intersections3-11
 - Figure 3.15 Off-Radial DME3-11
 - 3.4.8.5 Computer Navigation Fix (CNF)..... 3-11
 - Figure 3.16 CNF Example3-11
 - 3.4.8.6 Waypoints 3-12
- 3.4.9 Routes 3-12
 - Figure 3.17 Route Symbology3-12
- 3.4.10 Route Data 3-12
 - 3.4.10.1 Magnetic Bearing/RNAV Track Values 3-12
 - 3.4.10.2 Mileages 3-12
 - Figure 3.18 Bearing Values, Track Angles and Mileages3-12
 - 3.4.10.3 MEA, MOCA, etc 3-13
 - Figure 3.19 MEA and MOCA Depiction.....3-13
 - Figure 3.20 MEA Change Depiction3-13
 - 3.4.10.4 Route Data Stacking Order 3-13
 - Figure 3.21 Route Data Stacking Order.....3-13
 - 3.4.10.5 Changeover Points (COPs) 3-13
 - Figure 3.22 Changeover Point.....3-13
 - 3.4.10.5.1 Colocated Changeover Point and Fix 3-14
 - Figure 3.23 Changeover Point Located at a Reporting Point.....3-14
 - 3.4.10.5.2 Mileages on COP 3-14
 - 3.4.10.6 Airways/Routes (Coincidental and Noncoincidental)..... 3-14
 - Figure 3.24 Coincidental Routes.....3-14
 - Figure 3.25 Non-Coincidental Routes.....3-15

3.4.10.7	Restrictive Altitudes.....	3-15
	Table 3.2 Minimum, Maximum and Mandatory Altitudes	3-15
3.4.10.8	Restrictive Airspeeds	3-16
	Table 3.3 Restrictive Airspeeds	3-16
3.4.10.9	Paired Restrictive Airspeeds and Altitudes.....	3-16
3.4.10.10	Explanatory Notes.....	3-16
3.4.10.11	Holding Patterns.....	3-16
	Figure 3.26 Holding Patterns.....	3-16
	Figure 3.27 RNAV Holding Patterns	3-17
	Figure 3.28 Non-RNAV Holding Patterns	3-17
	Figure 3.29 Holding Patterns with Leg Length	3-17
	Figure 3.30 Lost Communication Holding Pattern	3-17
	Figure 3.31 Holding Patterns with Maximum Restricted Airspeeds.....	3-17
3.4.10.12	Terminus Identification Box	3-18
	Figure 3.32 Terminus Identification Box	3-18
3.4.11	Radial Lines.....	3-18
3.4.12	Bearing Lines.....	3-18
	Figure 3.33 Bearing Lines	3-19
3.4.13	Special Use Airspace (SUA)	3-19
	Figure 3.34 Special Use Airspace.....	3-19
3.4.14	Air Defense Identification Zone (ADIZ).....	3-19
	Figure 3.35 Air Defense Identification Zone (ADIZ) Boundary.....	3-20
3.4.15	Notes.....	3-20
3.4.15.1	PBN/Equipment Requirements Note Box.....	3-20
	Figure 3.36 PBN Requirements Note Box	3-20
	Figure 3.37 PBN/Equipment Requirements Note Box.....	3-20
3.4.16	Continued Arrival Route	3-21
	Figure 3.38 Graphic Continuation Box	3-21
3.5	Arrival Route Textual Description	3-21
3.5.1	General.....	3-21
3.5.2	Text.....	3-22
3.5.2.1	Transition Text (RNAV and non-RNAV)	3-22
	Figure 3.39 RNAV Transition Text.....	3-22
	Figure 3.40 Non-RNAV Transition Text	3-22
3.5.2.2	Arrival Text.....	3-22
3.5.2.3	Lost Communication Text	3-23
Appendix 1	Legend	A-1

Appendix 2	Page Layout	A-2
Appendix 3	East West Page layout	A-3
Appendix 4	Margin Data	A-4
Appendix 5	STAR with Transitions	A-5
Appendix 6	STAR with Arrival Only	A-6
Appendix 7	STAR with East-West Orientation	A-7
Appendix 8	Area STAR	A-8
Appendix 9	RNAV STAR	A-9
Appendix 10	STAR with Continued Page	A-10
Appendix 11	Conventional STAR with RNAV Waypoints	A-12
Appendix 12	STAR with CAUTION Note	A-13
Appendix 13	STAR with Offset Text Box	A-14
Appendix 14	PBN/Equipment Requirements Note Box	A-15
Appendix 15	Multiple Graphic STAR (2 Pages)	A-16
Appendix 16	Multiple Graphic STAR (3 Pages)	A-18
Appendix 17	Terminus Identification Box - Runway Terminus	A-21
Appendix 18	Terminus Identification Box - Airport Terminus	A-22

CHAPTER 1 GENERAL

1.1 PURPOSE AND SCOPE

1.1.1 Purpose

The purpose of these specifications is to provide appropriate guidelines to effect uniformity and standardization of content and portrayal techniques in the preparation and production of charts for use by both civil and military pilots operating in the National Airspace System.

1.1.2 Scope

A Standard Terminal Arrival (STAR) is a preplanned instrument flight rule (IFR) air traffic control arrival procedure published for pilot use in graphic and textual form. STARs reduce pilot/controller workload and air-ground communications, minimizing error potential in delivery and receipt of clearances. These specifications shall be used in the preparation of STAR Charts.

1.2 REQUIREMENTS

1.2.1 General

STAR Charts shall be prepared for all civil, military, and civil/military airports for which STAR procedures have been established and designated.

1.2.2 Quality and Accuracy

The highest standard of accuracy in plotting, reproduction, and currency of information contained therein, shall be maintained.

Although the digital chart files are compiled in accordance with these specifications, the final product may vary slightly in appearance due to differences in printing techniques/processes and/or digital display technique.

1.2.3 Color

STAR Chart information and supplemental textual material, as required, shall be prepared for a one color presentation. All information, textual and graphics, shall be in solid color, unless otherwise specified.

1.2.4 Scale

STAR charts generally shall be depicted 'not to scale' due to the great distances involved on many procedures and route segments. The portrayal may be distorted, but angular integrity should be maintained whenever possible. A 'to scale' depiction may be used only if the layout permits and readability is assured.

1.2.5 Projection

Projection shall be Lambert Conformal Conic or Polyconic.

1.2.6 Horizontal Reference

Charts referenced to horizontal datum other than North American Datum 1983 (NAD 83) will show a note; e.g., Horizontal Datum: WGS 72, indicating the datum used, in 7 pt. type, centered above the bottom neatline in the planview.

1.2.7 Symbolization

Symbolization shall be in accordance with the Aeronautical Information/Chart Symbols included in [Appendix 1](#).

The symbols contained in these specifications have been developed for use in the preparation of U.S. Government Aeronautical Charts.

These symbols have been developed through the United States Government Interagency Air Committee (IAC) and its supporting technical groups for the purpose of standardization of the aeronautical symbols portrayed on charts and publications used by both military and civil aviation.

The configuration of the symbols contained herein shall be adhered to. The size and line weights, specified and/or indicated herein, should also be adhered to, but may be varied when absolutely necessary.

1.2.8 Type Styles

The use of capital letters is intended, unless otherwise stated as C/L (capital and lower case letters).

All type, unless otherwise specified, shall be Futura Medium, as indicated on the various Appendices.

Type sizes specified herein shall be adhered to. However, and only in those areas of extreme congestion, or where a specified type size would create unnecessary congestion, the size of type may be reduced to the next smaller size.

1.2.9 Department of Defense (DoD) Exceptions and Differences

The National Geospatial-Intelligence Agency (NGA), as the DoD member of the Interagency Air Committee, has authority to take exception to any specified charting requirement. A footnote may be used to identify when NGA has taken an exception to a requirement in this specification. The footnote will be placed at the bottom left of the applicable page. Clarifying remarks may be added to the footnote, as applicable.

Figure 1.1 DoD Exception

3.5.2.14 Landing Direction Indicator

Wind cone, landing tee, and/or tetrahedron shall be shown in proper location.¹

1. RD 862 - NGA will not depict Landing Direction Indicators.

Minor charting differences will be indicated in the specification text with the agency to which it applies, i.e., (FAA) or (NGA).

1.3 SPECIFICATION APPENDICES

Appendices are included within these specifications for use in layout, format and content. Appendices do not necessarily reflect all possible operational content.

CHAPTER 2 FORMAT AND LAYOUT

2.1 FORMAT

The STAR procedure, including all textual and type data, shall normally be aligned with true North at the top of the page. Predominantly extensive East-West procedures shall be depicted in a landscape format in which North shall be toward the left side of the page. In such cases, the text will be oriented consistent with the geographic procedure and a North arrow shall be shown. The North arrow may be placed in any open space.

Figure 2.1 North Arrow



STAR Charts shall be arranged so that the planview of procedure is shown in the upper portion of the chart with the remaining lower portion containing the textual description of the procedure. These sections will be separated by a 6 weight (.012") line, so that the textual description will be “boxed” as illustrated in [Appendix 6](#). The box can be adjusted to accommodate the size of the description.

2.2 LAYOUT

Size and dimensions shall be annotated in [Appendix 2](#) and [Appendix 3](#).

Information shall be presented in textual, tabulated and graphic form, normally printed to read parallel to the top edge of the publication.

Page Intentionally Left Blank

CHAPTER 3 CONTENT

3.1 GENERAL

A STAR is a preplanned instrument flight rule (IFR) air traffic control arrival procedure. STAR Charts are designed to provide the pilot with all electronic aid information, together with procedural and other pertinent data required to execute the procedure. The chart portrayal shall be limited to one procedure.

3.2 COMPILATION

3.2.1 Relative Positioning

Cartographic judgment must be exercised in plotting the STAR procedure, mindful of the intent of the STAR program and the needs of the user. All turns, altitudes, NAVAIDs, including radio aids used in the formation of fixes germane to the procedure, shall be positioned on the graphic in their relative geographic location.

3.2.2 Scale

Every effort should be made to chart in relative geographic position. A ‘to scale’ graphic may be possible but, due to distances involved on some route segments, such a depiction may be the exception rather than the rule. On each chart so affected, a general statement as follows shall be shown along the bottom border line of the planview, using 7 pt. type. "NOTE: Chart not to scale."

Figure 3.1 Chart Not to Scale Note

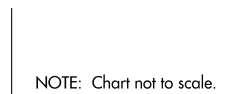

3.2.3 Displacement

All information shall be plotted to indicate its true (or relative in not-to-scale presentation) geographic location. If a NAVAID symbol is found to obliterate an airport symbol, the airport symbol shall be shifted enough to be completely clear of the NAVAID.

3.2.4 Alignment

The STAR procedure shall normally be aligned with true north at the top of the page. Exceptions to this shall be for predominately extensive east/west procedures which may be aligned with north to the left of the page. In such cases, the textual descriptions or type data shall read with the graphic procedure. East/West textual descriptions will be “boxed” wherever they are positioned in the planview. The box may be adjusted to accommodate the size of the description.

3.2.5 Placement of Identification and Notes

Identification and data notes shall be positioned adjacent to, or as near the symbol as possible, except when such placement would result in the obliteration of other detail, the information may be leadered.

3.3 MARGIN DATA

Margin data is defined as that information required to be shown between the borderline of the STAR Chart and the trim. The margin data below is required to be shown positioned as illustrated.

Figure 3.2 Margin Information - Single Airport (Top and Bottom)

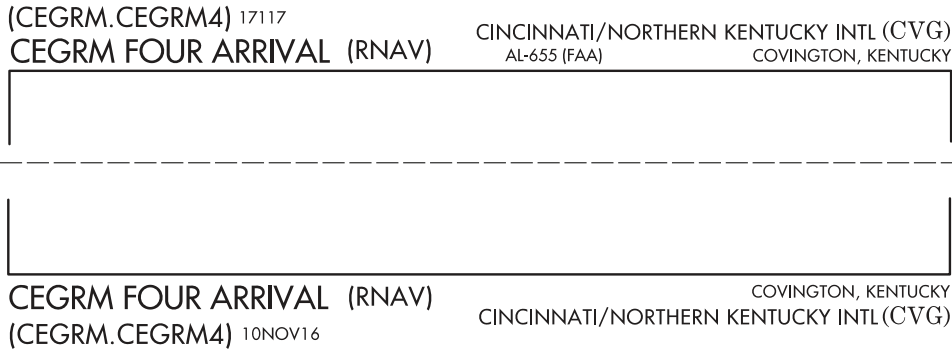
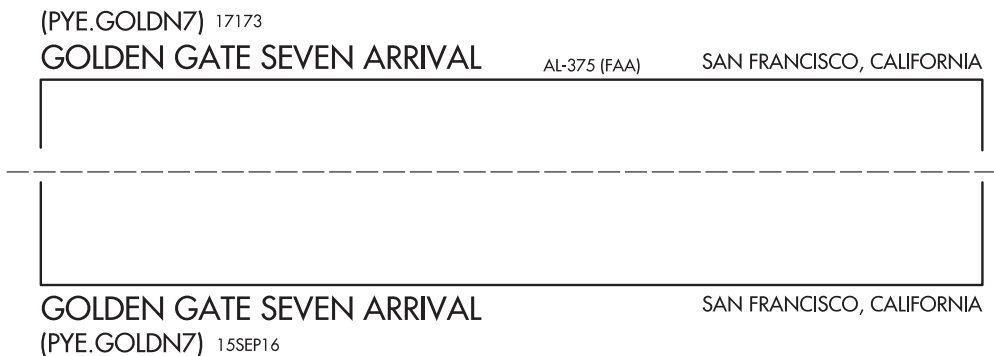

Figure 3.3 Margin Information - Area STAR (Top and Bottom)



References:

[Appendix 4 - Margin Data](#)

3.3.1 Procedural Designation

The arrival procedure name, number, and computer code assigned by the authority establishing the procedure, e.g. CEGRM ONE ARRIVAL (RNAV)(CEGRM.CEGRM1) shall be shown.

If indicated, RNAV will be shown in the chart title in parentheses after the word ARRIVAL.

To distinguish between the number zero and the letter “O” within the computer code, a slash shall be shown through the zero.

3.3.1.1 Multipage Graphics

If deemed appropriate to break a STAR into a two page graphic, the STAR name and type will be followed by a subtitle identifying the area being depicted, e.g., Transition Routes, Arrival Routes. The subtitle will be 10 pt. C/L.

Each individual graphic page for a multipage graphic will be in the layout that best accommodates the routing, i.e. east-west landscape or north-south portrait, and each graphic page does not have to be in the same orientation.

References:

[Appendix 15](#) - Multiple Graphic STAR (2 Pages)

3.3.2 Julian Date

The Julian date, which reflects a chart revision of any type, will be placed above the top neatline, adjacent and to the right of the computer code. If no computer code exists, the Julian date will be left justified above the procedure name.

3.3.3 Procedure Effective Date

The AIRAC date of the last procedural revision will be placed below the bottom neatline, adjacent and to the right of the computer code. If no computer code exists, the procedure effective date will be left justified below the procedure name.

3.3.4 Chart Reference Number

The chart reference number shall be preceded by the series code “AL” and dash followed by the abbreviated name of the appropriate authority for the procedure, placed inside parenthesis; e.g.; AL-000(FAA); AL-000(FAA-O). Military procedures do not show a chart reference number, but do show the appropriate authority for the procedure, e.g., (USN).

3.3.5 Airport Name and Identifier

The airport name, extracted verbatim from the authoritative database, immediately followed by the airport location identifier shown in parenthesis, shall be shown at the top and bottom margins. Civil and joint-use airports will be shown with the FAA airport location identifier. Airports outside the contiguous United States will be shown with the FAA airport location identifier followed by the ICAO location indicator. Military airports that are not joint-use will be shown with only the ICAO location indicator. When more than one airport is served by the STAR procedure, the airport/s name and identifier shall be omitted.

3.3.6 Location

The geographic location, consisting of the city and state name associated with the airport/s.

3.4 PLAN VIEW

References:

[Appendix 2](#) - Page Layout

[Appendix 3](#) - East West Page layout

3.4.1 General

The chart shall encompass the area required to effectively show the arrival routing, including transitions from the appropriate enroute structure.

One procedure shall be shown on each chart.

All routes, turns, altitudes, NAVAIDs, facilities forming intersections and fixes, and those facilities/fixes terminating or beginning the arrival route shall be shown in the graphic depiction.

In congested areas the lightning bolt type leader lines may be used to reference a fix/intersection/way-point to its correlating point.

Figure 3.4 Lightning Leader

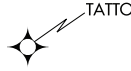

Ideally, both the graphic and textual description will be depicted on a single page. However, when not feasible, the textual description can be published on an additional page(s) as shown on [Appendix 10](#).

When the graphic cannot fit entirely on one page, the first page typically will show the Transition Routes up to and including the common point which commences the Arrival Route segments. The arrival routes will be shown on the following page.

When utilizing continuation page(s), each preceding page will include the note “(CONTINUED ON FOLLOWING PAGE)” in 9 pt type shown preferably at the bottom of the chart directing users to the next page.

References:

[Appendix 10](#) - STAR with Continued Page

[Appendix 15](#) - Multiple Graphic STAR (2 Pages)

[Appendix 16](#) - Multiple Graphic STAR (3 Pages)

3.4.2 Communications

3.4.2.1 General

Communications information, when available, shall be shown in the upper left corner, as indicated on the Appendices, in such a manner so as not to interfere with significant items of the procedure. When necessary, communications information may be shown in the upper right corner. Type size shall be 7 pt.

The typical format for communications is the name on one line followed by the frequency(ies) underneath it. All data shall be justified left or right as appropriate to the corner placement.

On a multipage graphic STAR, all communications will be charted on every page that contains graphics.

When published in the source database, frequencies may be sectorized. The sectors can be listed by cardinal or ordinal directions (e.g., N, NE), bearings (e.g., 090°-224°) and runways (e.g., 16R-34L, 16C). The sectorized information will be indicated within parentheses to the right of the appropriate frequency.

3.4.2.2 Standard Communications

APP CON and ATIS or AFIS (AK) will always be charted with APP CON, listed before ATIS/AFIS.

3.4.2.2.1 Approach Control (APP CON)

Approach Control shall be shown by name and abbreviated; e.g., “Name APP CON”. Multiple APP CON frequencies may be charted when published in the source database.

3.4.2.2.2 Automatic Terminal Information Service (ATIS)

Automatic Terminal Information Service shall be shown by the letters “ATIS” followed by the specific frequency. If the service is digital and listed as D-ATIS in the authoritative source database, “D-ATIS” shall be shown followed by the specific frequency.

When the service provided is either arrival and/or departure on different frequencies, only the arrival frequencies shall be shown.

3.4.2.2.3 (AK) Automated Flight Information Service (AFIS)

Automated Flight Information Service shall be shown by the letters “AFIS” followed by the specific frequencies.

3.4.2.2.4 Area STAR Communications

When more than one airport is served by the STAR procedure, the airport location identifier of the civil airport/s providing ATIS shall be shown, and for military airports, only the ICAO identifier shall be shown. When requested on the procedure source form, the airport location identifier of the civil airport/s providing AWOS or ASOS shall be shown, e.g., HGR ASOS 118.325. Civil airports located outside the contiguous U.S. will also include the ICAO identifier, e.g., MRI/PAMR. Multiple ATIS/AFIS/AWOS/ASOS will be ordered alphabetically by identifier.

Figure 3.5 Area STAR Communications

MIAMI APP CON	ANCHORAGE APP CON
124.85 263.025	126.4 270.25
KHST ATIS★	ANC/PANC D-ATIS
132.275 269.9	135.5
MIA D-ATIS	MRI/PAMR ATIS
119.15	124.25
TMB ATIS	PAED ATIS★
124.0	124.3 273.5
X51 AWOS-3	
118.375	

3.4.2.2.5 Hours of Operation

Hours of operation shall not be shown. Part-time frequencies will be annotated with a star.

Figure 3.6 Part-time Operation Depiction

JUNEAU TOWER★
118.7 (CTAF) 278.3

3.4.2.3 Additional Communications

Additional Communications will only be shown when specifically requested on the procedure source form and preceded with the command CHART and will be listed in the below sequence. Additional communications, as identified, shall not exceed one VHF and one UHF primary frequency for each of the following:

- CENTER
- APP CON
- ATIS (D-ATIS) (AFIS)
- AWOS/ASOS
- GND CON
- TOWER (CTAF)

3.4.2.4 Automated Weather Systems (ASOS/AWOS)

Automated Weather Systems (AWOS/ASOS) shall be show by the system type, followed by the level and the frequency; e.g., AWOS-3 124.65 or ASOS 118.975.

3.4.3 Fly-over Symbology

Enroute fixes/intersections, waypoints, and NAVAIDs that are designated as fly-over on RNAV STARs will be shown as indicated in [Appendix 1](#). However, enroute fixes/intersections, waypoints, and NAVAIDs designated as a holding point will be charted as a fly-by, without the circle around the symbol. In the event the holding point is also designated in all other parts of the procedure unrelated to holding with a fly-over function, then the holding point will be charted as a fly-over point.

On STAR procedures serving more than one airport, a point may be designated as a fly-over on one of the arrival routes, and as a fly-by for another. When a point on the same chart has both designations, it will be charted as a fly-by.

3.4.4 Compulsory Reporting Points

Fixes, reporting points, intersections, NAVAIDs, and waypoints designated as compulsory will be designated as indicated in [Appendix 1](#).

3.4.5 Airports

All airport/s of destination shall be shown, symbolized as either civil, military, or civil/military as shown in [Appendix 1](#).

On STAR procedures serving more than one airport, all airports shown shall be identified by name using 7 pt. type. Airport names will be extracted verbatim from the authoritative database.

When an airport(s) not served by the procedure is requested for charting on the procedure source document, it shall be shown using a screened color.

3.4.6 Radio Aids to Navigation (NAVAIDs)

3.4.6.1 General

NAVAIDs used in the procedure, including transitions and those shown only to establish fixes, intersections, etc., shall be shown, positioned in their relative geographical location with the following exception: NAVAIDs that are located beyond the established limits of the chart area shall be brought, or moved within the neatline of the planview, retaining magnetic bearing and distance relationship. Mileage and bearing values, etc., shall, however, be accurate.

In congested areas, where a box depiction is not feasible, NAVAIDs that are located beyond the established limits of the chart area and used to establish fixes, intersections, etc., shall be identified by using a 2 weight (.006") radial line with the facility identifier, frequency and channel number positioned along and parallel to the radial line.

3.4.6.2 Frequencies Without Voice

Frequencies without voice capability, except TACAN and DME, shall be underlined using a 2 weight (.006") line, the length of the frequency numbers.

3.4.6.3 Symbolization and Identification of NAVAIDS

NAVAIDs shall be appropriately symbolized and identified in 7 pt. type. The following information as appropriate for the type of NAVAID in the order listed shall be enclosed within an identification box: name, frequency, identifier, morse code, channel number and paired VHF frequency.

Figure 3.7 NAVAID Symbolization

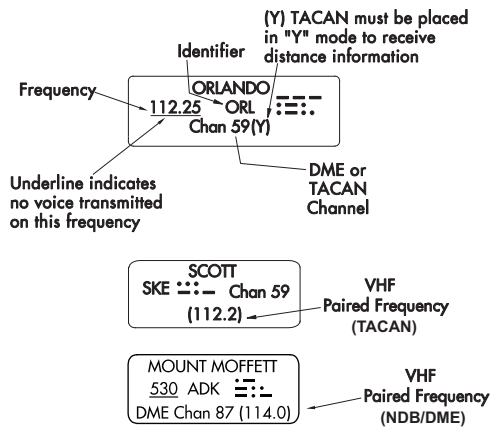

3.4.6.3.1 Frequency Protection Range (T)

A capital letter (T) in parentheses shall be shown within the facility identification box following the frequency to indicate the frequency protection range (usable range at 12,000', 25NM) of such radio aids to navigation.

3.4.6.3.2 Leader Lines

The leader line shall extend from the data box to and without touching the appropriate NAVAID.

3.4.6.3.3 Line Weight

Line weight for boxes and leader lines shall be 3 weight (.006").

3.4.6.3.4 NAVAID Boxes

Boxes shall be of a size consistent with the informational data contained therein.

3.4.6.4 “Y” Mode NAVAIDS

NAVAIDs with a DME, when the DME operates in the “Y” mode, the “Y” will be enclosed in parenthesis and positioned immediately following the channel number, e.g., Chan 00(Y).

3.4.6.5 Instrument Landing System (ILS) Localizer Course

The Instrument Landing System (ILS) Localizer Course, either the front, back, or both courses, shall be shown when identified on the procedure source document. The fan symbol shall emanate from the appropriate airport symbol in its correct magnetic orientation. Since no specific localizer position is being portrayed, the NAVAID box shall point to the fan. The back course, when shown, shall be identified as "BACK COURSE" positioned along and parallel to the course.

Figure 3.8 ILS Localizer Course

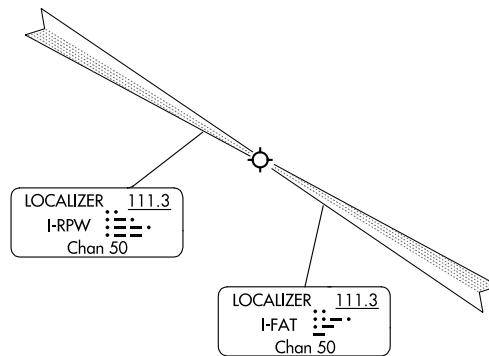

Simplified Directional Facilities (SDF) shall be shown in accordance with the above, as illustrated in [Appendix 1](#).

3.4.6.5.1 Localizers on RNAV STARs

When requested on the procedure source document, a localizer fan will be shown emanating from the appropriate runway end in its magnetic orientation. The fan will be reduced in size to fit the available space. The localizer identifier will be positioned along and parallel to the localizer fan using 7 point type.

Figure 3.9 Localizer on RNAV STAR

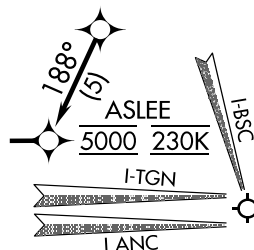

3.4.7 RNAV STARs

3.4.7.1 NAVAIDs

NAVAIDs on RNAV STARs shall show only the applicable NAVAID symbol, with NAVAID name and three letter identifier, in 8 point type. NAVAID data shall not be boxed. When necessary, the NAVAID name and ident may be leadered to the NAVAID symbol by a lightning-type leader.

3.4.7.2 Leg Types

On RNAV STARs, leg type abbreviations VA = Heading (Vector) to Altitude, FM = Fix to Manual Termination, VM = Vector to Manual Termination, DF = Direct to Fix, CF = Course to Fix, TF = Track to Fix, shown on the procedure form will be charted as follows:

Table 3.1 Leg Types

7100-3	7100-4	Charting
VA	Heading	No waypoints and no mileage shown, heading shown (i.e.92), no mileage shown.
FM	Track	No waypoint at termination of leg and no mileage shown, heading (i.e. 92).
VM	Heading	No waypoint at termination of leg and no mileage shown, heading (i.e. 92).
DF	Direct	No course and mileage shown, waypoint at termination of leg
CF	Course	Course shown, mileage shown only if first leg, waypoint at termination of leg
TF	Track	Course and mileage shown, waypoints at beginning and termination of leg

Figure 3.10 Waypoint Depiction

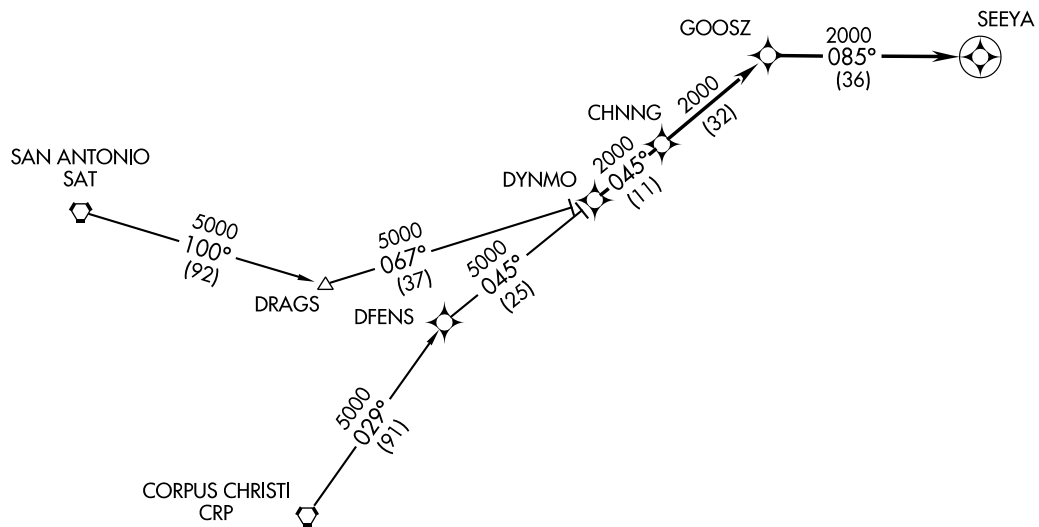

3.4.8 Named DME Fixes, Unnamed DME Fixes, Intersections, Computer Navigation Fixes (CNF) and Waypoints

3.4.8.1 General

DME fixes, intersections, fixes, CNFs and waypoints described in the STAR shall be shown and illustrated as described in [Appendix 1](#). Identification shall be by name in 8 point type.

References:

[Appendix 1](#) - Legend

3.4.8.2 Named DME Fixes

Named DME fixes shall be identified by the placement of small open arrowheads (.12 in length) pointing to the fix from the VHF/UHF NAVAID forming the fix. These open arrowheads shall be positioned adjacent to the fix, along and parallel to the route or radial.

These open arrowheads will be supplemented with an open "D" attached to the shaft of the DME arrowhead, with the DME mileage centered therein when the mileage from the NAVAID is not obvious.

Fixes/Intersections with multiple DMEs will only depict the DMEs from NAVAIDs that also form transition, arrival or lost communication routes.

Type size and style for the DME mileage shall be 7 pt expressed in whole miles except when less than one mile and then specified on the procedure source document.

Figure 3.11 Named DME Fix

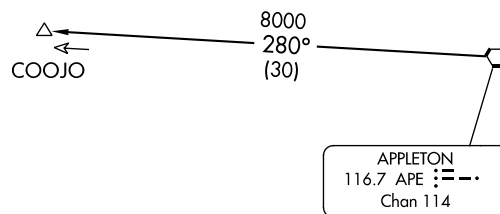

3.4.8.3 Unnamed DME

Unnamed DME fixes shall be shown by a 2 weight (.006"), .2" long, centered across the appropriate radial or route line, supplemented by the open arrow and "D" symbol described above. The associated mileage figure for RADAR fixes shall be positioned adjacent to the line symbol and shall be identified in nautical miles.

Type size and style for the DME mileage shall be 7 point, expressed in whole miles except when less than one mile and when specified by the procedure source document.

Figure 3.12 Unnamed DME Fix

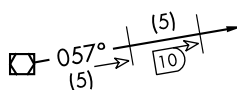

If a CNF is colocated with a DME fix the “x” symbol will not be shown.

Figure 3.13 Unnamed DME Fix with Colocated CNF

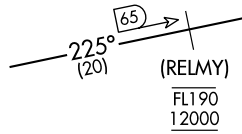

3.4.8.4 Intersections

Intersections are points in space formed by two or more NAVAIDs.

Figure 3.14 Intersections

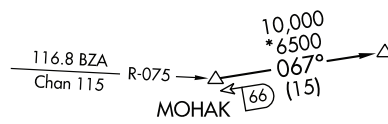

Entry Point Intersection
Used to execute the procedure & originates from the enroute environment

Executing Intersection
Used to execute the procedure

Figure 3.15 Off-Radial DME

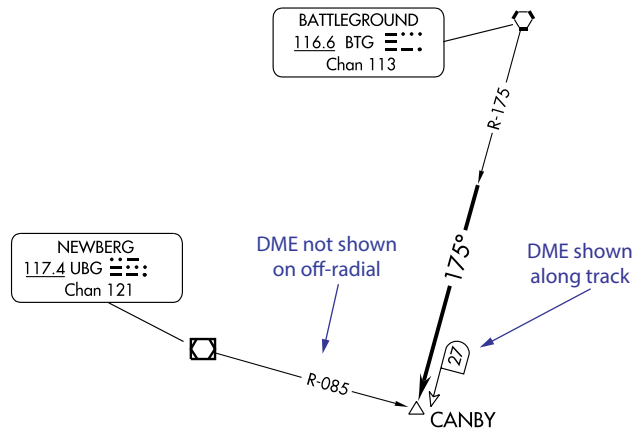

3.4.8.5 Computer Navigation Fix (CNF)

A CNF shall be shown with the symbol “x” at a dog-leg of the route when defined as part of the procedure. The 5-character CNF name shall be shown in parentheses.

Figure 3.16 CNF Example

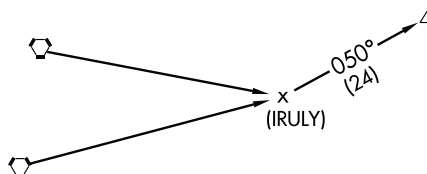

3.4.8.6 Waypoints

Waypoints that are intended only for use by onboard database navigation systems, and have an ATC function shall be charted. The assigned five letter waypoint name will be charted adjacent to the waypoint icon in 8 point type. When a waypoint is created at the same geolocation as an existing fix, NAVAID, or reporting point, the waypoint symbol will not be charted. Only the existing fix, NAVAID, or reporting point and its associated data will be shown.

3.4.9 Routes

Arrival, lost communications and transition routes shall be shown, broken for all symbols and for the insertion of bearing values or RNAV track angles. Directional arrowheads shall be positioned on the routes, near, but not touching the symbol.

Figure 3.17 Route Symbology



Transition routes, as designated, shall be shown emanating from the entry facility/fix to a common point or fix from which a single STAR commences. Transition routes with a name differing from the initial facility/fix, and therefore not identified, shall be identified by name, positioned adjacent to the transition route symbol.

3.4.10 Route Data

All route data shall apply to both RNAV and NAVAID STARs unless otherwise stated.

3.4.10.1 Magnetic Bearing/RNAV Track Values

Magnetic bearing or RNAV track values shall be shown in three digits (to the nearest degree) positioned on and breaking the route or transition line along each segment as space permits, including after the final fix in the arrival. A degree sign shall be shown with all headings. Type size shall be 9 pt. When a route or track line would be obliterated by placement of the heading value, it may be placed above or below the line, as space permits.

3.4.10.2 Mileages

Nautical mile distances (mileages) between primary NAVAIDs, intersections, fixes, and waypoints along the route shall be shown rounded to the nearest whole nautical mile, within parentheses, normally below the route symbol. Type size shall be 8 pt.

Figure 3.18 Bearing Values, Track Angles and Mileages

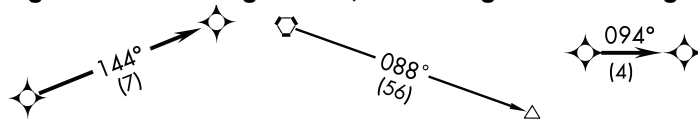

3.4.10.3 MEA, MOCA, etc

MEA, MOCA, etc., as designated and specified on the procedure source document shall be shown, normally above the route heading, using 8 pt. type. MOCA shall be preceded by a 9 pt. asterisk. Altitudes of 18000 feet and above shall be expressed in thousands of feet or as a flight level (e.g. FL180), as provided on the procedure source form. A "T" shaped symbol, as illustrated in the appendices, shall be used to designate a change in MEA when established at points other than NAVAIDs. The transition from a specified MEA to no specified MEA is not considered a change in MEA. In such cases, the "T" symbol will not be used and the route will be charted with a closed arrowhead.

Figure 3.19 MEA and MOCA Depiction

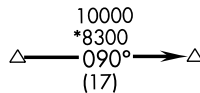
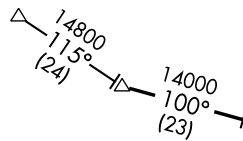

Figure 3.20 MEA Change Depiction



Other requested altitudes such as MAA, MRA, etc., will be shown above the MEA preceding by their identifier, e.g., MAA FL450, MRA18000. Type size shall be 8 pt.

3.4.10.4 Route Data Stacking Order

Route data shall be stacked in the order of preference shown in **Figure 3.21**, depending on the space available.

Figure 3.21 Route Data Stacking Order

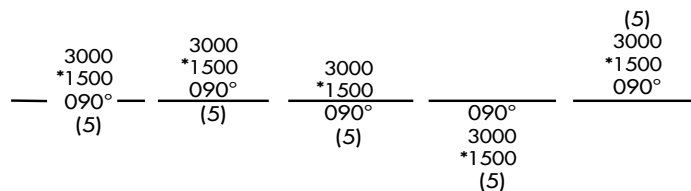

3.4.10.5 Changeover Points (COPs)

Changeover Points shall be shown when specified on the procedure source document.

The heavy bar of the symbol shall be centered on and at a 90° angle to the route. When aligned with the route data, the symbol shall be positioned so that the short top line shall be parallel with the route and "point" to the right; the short bottom line shall also be parallel to the route and "point" to the left.

Figure 3.22 Changeover Point

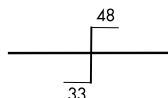

3.4.10.5.1 Colocated Changeover Point and Fix

When a COP is located at a fix, except when colocated with a DME fix, the COP symbol shall be broken for the fix symbol. When colocated with a DME fix, the COP shall be offset from the fix. The COP symbol shall not touch the fix symbol.

Figure 3.23 Changeover Point Located at a Reporting Point

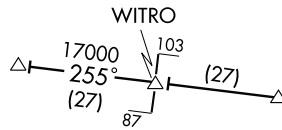

3.4.10.5.2 Mileages on COP

Mileage figures from the COP to the next and preceding VHF/UHF NAVAID shall be positioned .02" above or below the short "pointer lines" of the symbol, parallel with the route using 7 pt. type. However, in areas where this placement is not in the best interest of clarity, the mileage figures may be centered .02" from ends of the short "pointer lines" of the symbol, parallel with the route.

When the COP is located at a reporting point or a DME fix, the changeover mileage figure shall be omitted, provided there is no intervening mileage breakdown point between the changeover point and the NAVAID.

3.4.10.6 Airways/Routes (Coincidental and Noncoincidental)

When the arrival or transition route coincides with an airway/route, and is identified in the procedure, the airway/route identification shall be shown, using 7 point type, enclosed in a 2 weight (.006") box. When an airway/route is requested that is not coincident with an arrival or transition route, it will be shown with a 2 weight (.006") line in the same way, except non-RNAV will provide a radial, RNAV will not.

Figure 3.24 Coincidental Routes

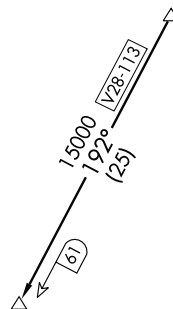
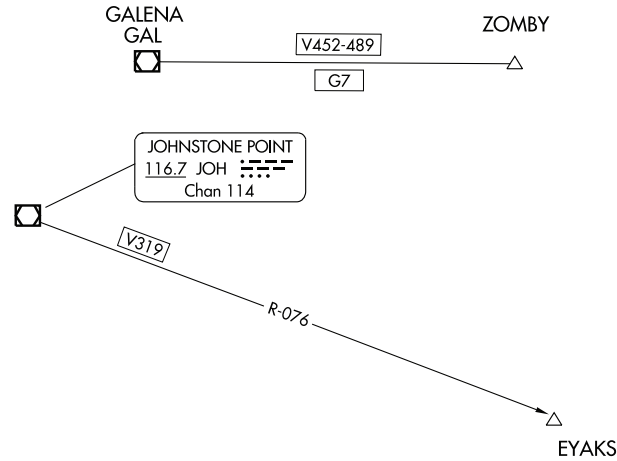

Figure 3.25 Non-Coincidental Routes



3.4.10.7 Restrictive Altitudes

Restrictive altitudes along the arrival route shall be shown using 8 point type.

Altitude values shall not include commas (15000).

Minimum, Maximum and Mandatory Altitudes shall be shown and be clearly identified with the fix to which they apply. The use of a line above the text and a line below the text on altitudes of the procedure shall be as appropriate to the wording of the procedure, as depicted in the **Table 3.2** below.

Restrictive altitudes at NAVAIDs, fixes and waypoints along the arrival/transition route shall be shown, when specified by appropriate authority, without annotation and adjacent to the point with which they are associated and in accordance with established minimum/maximum/mandatory altitude charting conventions.

Table 3.2 Minimum, Maximum and Mandatory Altitudes

Type	Description	Example
Minimum Altitude	Minimum altitudes shall be depicted as an underlined number. This is an MSL altitude, vertical to a geographic location below which an aircraft may not descend. Cross at or above 12000 will be show as depicted. Expect clearance to cross at or above an altitude will be shown as "Expect <u>12000</u> ".	<u>12000</u>
Maximum Altitude	Maximum altitudes shall be depicted with a line above it. This is an MSL altitude, vertical to a geographic location, above which an aircraft may not be flown. Cross at or below 12000 will be show as depicted. Expect clearance to cross at or below an altitude will be shown as "Expect <u>12000</u> ".	<u>12000</u>
Mandatory Altitude	Mandatory altitudes shall be depicted as a number with a line above and below. This is an MSL altitude, vertical to a geographic location which an aircraft must maintain. Cross at an altitude will be shown as depicted. Expect clearance to cross at an altitude will be shown as "Expect <u>12000</u> ".	<u>12000</u>

Table 3.2 Minimum, Maximum and Mandatory Altitudes (Continued)

Type	Description	Example
Block Altitude	Block altitudes shall be depicted as the combination of Minimum and Maximum altitudes as depicted. Expect clearance for a block altitude will be shown as "Expect <u>15000</u> <u>12000</u> Block altitudes may be worded as 'Cross above 12000 and below 15000' or 'Expect clearance to cross above 12000 and below 15000'.	<u>15000</u> <u>12000</u>

3.4.10.8 Restrictive Airspeeds

Restrictive airspeeds along the procedure track shall be shown using 8 point type. The use of a line above the text and a line below the text on airspeeds of the procedure shall be as appropriate to the wording of the procedure, as depicted in [Table 3.3](#) below.

Table 3.3 Restrictive Airspeeds

Type	Description	Example
Minimum Speed	Minimum airspeeds shall be depicted as an underlined number. Cross at or above 170K will be shown as depicted.	<u>170K</u>
Maximum Speed	Maximum airspeeds shall be depicted as a number with a line above it. Cross at or below 170K will be shown as depicted.	<u>170K</u>
Mandatory Speed	Mandatory airspeeds shall be depicted as a number with a line above and below. Cross at 170K will be shown as depicted.	<u>170K</u>

3.4.10.9 Paired Restrictive Airspeeds and Altitudes

Paired restrictive altitudes and airspeeds shall be depicted individually as above. They are positioned side-by-side when space allows.

3.4.10.10 Explanatory Notes

Appropriate explanatory notes may be shown, as required, positioned along the arrival or transition route using 8 point C/L type and punctuations.

3.4.10.11 Holding Patterns

Holding patterns shall be shown using a 2 weight (.006") racetrack-type symbol broken for 7 pt bearings with arrowheads indicating direction of turns. If the inbound leg of the hold is coincident with an arrival or transition track (i.e. same value), the inbound bearing, 2 weight (.006") line, and arrowhead may be eliminated.

Figure 3.26 Holding Patterns



RNAV holding patterns shall include a 2 weight (.006") "tick mark" and 7 pt leg length.

Figure 3.27 RNAV Holding Patterns

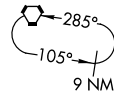

Non-RNAV holding patterns will include a holding radial when the pattern is not coincident with the arrival or transition track. Exception shall be when the holding involves an NDB or LOM which do not provide radials.

Figure 3.28 Non-RNAV Holding Patterns



If a nautical mile leg length or DME leg length is requested on the procedure source document for a non-RNAV hold, they shall be shown as illustrated below.

Figure 3.29 Holding Patterns with Leg Length



Holding patterns associated with lost communications shall be shown using the dotted line pattern instead of a solid line.

Figure 3.30 Lost Communication Holding Pattern

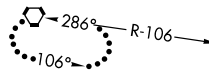

Maximum restricted airspeeds, when requested on the procedure source document, shall be depicted within the holding pattern symbol, with the restricted airspeed in parentheses, as shown in [Appendix 1](#). As restricted airspeeds, 210K applies to altitudes above 6000 feet to and including 14000 feet and 175K applies to all altitudes.

Figure 3.31 Holding Patterns with Maximum Restricted Airspeeds

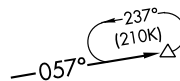

All supplemental information (i.e. distances, speeds, etc) shall be 7 pt.

3.4.10.12 Terminus Identification Box

A Terminus Identification Box will be shown at each of the STAR terminus points when requested on the procedure source document. Type size shall be 8 pt. enclosed in a 3 weight (.006") box.

Figure 3.32 Terminus Identification Box

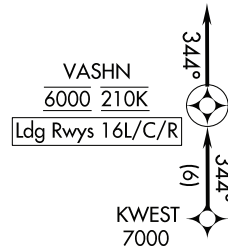

References:

[Appendix 17](#) - Terminus Identification Box - Runway Terminus

[Appendix 18](#) - Terminus Identification Box - Airport Terminus

3.4.11 Radial Lines

Those radials that are associated with the arrival route, intersections, reporting points and mileage fixes shall be shown and identified.

Radial lines shall be shown by 2 weight (.006") arrowed line emanating from the facility with the value positioned on and breaking the arrowed line, preceded by the letter "R". Radial values shall be in three digits; e.g., R-000. A degree sign shall not be shown with radial values. Type size shall be 7 pt. Lead Radials, when identified on the procedure source document, shall be additionally identified from the letters "LR" preceding the numbered value; e.g., LR-053.

Radial lines shall stop just short of the applicable intersection or fix so as not to be in conflict or interfere with the route depiction.

In congested areas, radial values may be placed in a clear area and related to the radial by a 1 weight (.005") arrowed line.

When a radial line overlies a course/route/transition line going to a NAVAID, the radial value (i.e. R-322) shall be shown above the heavier weight line, adjacent to the NAVAID.

3.4.12 Bearing Lines

Those bearings associated with the arrival route, intersections, and mileage fixes shall be shown and identified.

Bearing lines shall be shown by a 2 weight (.006") arrowed line from the fix to the NAVAID, with the value positioned on and breaking the arrowed line. Bearing values shall be in three digits. A degree sign shall be shown with all bearing values. Type size shall be 7 pt.

Bearing lines shall be shown through the applicable reporting point or fix and broken for symbol so as not to be in conflict or interfere with the route depiction.

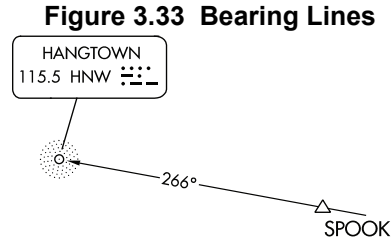

In congested areas, values may be placed in a clear area and related to the bearing line by 1 weight (.005") arrowed line.

3.4.13 Special Use Airspace (SUA)

Special Use Airspace shall be shown only when requested by the formulating agency.

Special Use Airspace shall be portrayed by a 2 weight (.006") diagonal line pattern, .10" in width, positioned so as to have the lines in a NE to SW direction. In no case will the portrayal of Special Use Airspace obliterate the functional procedural data. Should an area be too small to portray the specified width, the width shall be proportionately reduced in size to adequately portray the area. In "not to scale" depictions, SUA may be resized but shall remain in its relative position to the rest of the portrayal.

SUA outer boundaries shall be depicted by a 3 weight (.006") line.

SUA internal boundaries shall be depicted by a 1 weight (.005") line to separate the individual SUA areas.

Special Use Airspace shall be identified by the designated number and/or name of the area; e.g., P-1234, R-1235, YUKON 1 MOA, etc., using 7 point type.

Figure 3.34 Special Use Airspace

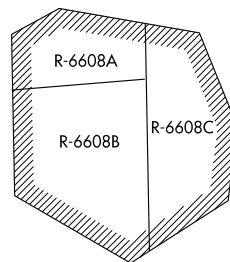

3.4.14 Air Defense Identification Zone (ADIZ)

When designated on the procedure source document, ADIZ boundaries that all within the area of coverage of the STAR chart shall be shown.

ADIZ boundaries shall be portrayed by a 4 weight line (0.010"). The diameter of the dots is .015". The width of the symbol is .05". Identification shall be placed within or along the boundary. In no case, will the portrayal of the ADIZ obliterate the functional procedural data.

Figure 3.35 Air Defense Identification Zone (ADIZ) Boundary

CONTIGUOUS U.S. ADIZ
.....

3.4.15 Notes

Operational notes, when requested by the formulating agency, shall be shown. Notes shall be prefaced with "NOTE:". Exception will be for specific note categories such as TURBOJET VERTICAL NAVIGATION PLANNING INFORMATION, CAUTION, LANDING ALL RUNWAYS, etc. See [Appendix 12](#) for an example.

Type size for notes shall be 8 pt. C/L. Acronyms (DME, RADAR, VORTAC) shall be in all caps. The foot symbol (') will always be used to indicate "feet" or "ft" in all notes, e.g., 500'.

When multiple runway ends are listed for the same line of information, they will be listed in numerical order from 1 to 36. When parallel runways are listed they will be listed in the order left, center, right, e.g., 1R, 16L/C/R, 19L.

Combine and locate notes in a single area to the greatest extent possible. Preferred location shall be in the lower left of the planview, moving clockwise when the lower left is not feasible. Notes that pertain to a specific fix, NAVAID, or waypoint shall be located adjacent to that point.

On a multipage graphic STAR, all planview notes will be charted on every graphic page.

3.4.15.1 PBN/Equipment Requirements Note Box

When indicated on the procedure source document, an Equipment and/or PBN Requirements notes box shall be shown on the top right corner of the planview. When planview configuration does not allow this positioning, placement may vary to the top left corner, then along the top neat-line, and finally to where space allows. Type size shall be 8 point text enclosed in a 3 weight (.006") box. When more than one PBN Requirement Note is specified on the procedure source document, the notes will be stacked within the same box.

Figure 3.36 PBN Requirements Note Box

RNAV 1 - DME/DME/IRU or GPS.

When the procedure source document indicates both a PBN requirement note and an equipment requirement note, two stacked boxes will be shown. PBN Requirements notes will be listed in the first box. Equipment Requirements will be listed in the second box.

Figure 3.37 PBN/Equipment Requirements Note Box

RNAV 1 - DME/DME/IRU or GPS.
RADAR required.

References:

[Appendix 14](#) - PBN/Equipment Requirements Note Box

3.4.16 Continued Arrival Route

When a multipage graphic is being used, the common point and all associated information such as altitudes, speeds and holding patterns, will be depicted in a 2 weight (.006") dashed box with the a 7 point note “See following page for arrival route” directing the user to the graphic on the following page as shown in Figure 3.38. Box size is not fixed but shall be of a size to encompass the standard note, terminating point, and any associated information.

Figure 3.38 Graphic Continuation Box

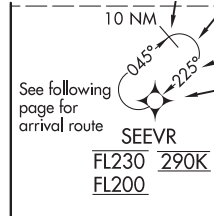

References:

[Appendix 16](#) - Multiple Graphic STAR (3 Pages)

3.5 ARRIVAL ROUTE TEXTUAL DESCRIPTION

3.5.1 General

The heading “ARRIVAL ROUTE DESCRIPTION” and the arrival route text shall be printed within the planview area. The preferred type size of the arrival route text is 9 pt, C/L. If the allotted space does not accommodate the textual route description, 8 pt may be used. Transition, arrival and lost communication description headings shall be in capital letters and underlined.

When the description is of such length that the provisions of the above paragraph cannot be met, then a continuation page(s) may be added for the Arrival Route textual description. On a multipage graphic, the transition text will be charted on the transition graphical page with no textual heading and will not be repeated on the continuation page with the arrival route description. See [Appendix 16](#). If, due to space constraints, the transition text cannot be placed on the transition page, it will be placed on the narrative page before the arrival route text. The continuation page(s) shall have the same marginal information as its associated arrival chart. The heading "ARRIVAL ROUTE DESCRIPTION" shall be centered inside the upper border in 9 pt. type on the first page used. Any additional pages will be titled “(CONTINUED)” and shall be centered inside the upper border in 9 pt. type.

References:

[Appendix 10](#) - STAR with Continued Page

3.5.2 Text

3.5.2.1 Transition Text (RNAV and non-RNAV)

For RNAV charts, transition text will consist of the transition name and associated computer code (caps/underlined). There shall be no following narrative.

Figure 3.39 RNAV Transition Text

ARRIVAL ROUTE DESCRIPTION
KEESH TRANSITION (KEESH.ANTHM3)
KEMAN TRANSITION (KEMAN.ANTHM3)
NUSMM TRANSITION (NUSMM.ANTHM3)

For non-RNAV charts, transition text will begin with the name and computer codes as outlined above. A narrative, created by the charting proponent, will follow. The narrative will describe all turns, altitudes, radials, bearings and facilities/fixes needed to guide the user from the entry point to the common facility/fix. The end of the transition(s) text will use a “Thence....” format to lead into the arrival text.

Figure 3.40 Non-RNAV Transition Text

ARRIVAL ROUTE DESCRIPTION
CYPRS TRANSITION (CYPRS.LEENA4): From over CYPRS INT via MGO R-295 to MCKEY INT, then via BSR R-131 to DAISY INT, and SXC R-287 to SXC VORTAC. Thence....
DAISY TRANSITION (DAISY.LEENA4): From over DAISY INT via SXC R-287 to SXC VORTAC. Thence....
FELLOWS TRANSITION (FLW.LEENA4): From over FLW VORTAC via FLW R-123 to SADDE INT, then via FIM R-148 to PAROL INT, and SXC R-310 to SXC VORTAC. Thence....

When multiple transitions exist, they shall be arranged alphabetically by transition name.

3.5.2.2 Arrival Text

A description of the arrival procedure (common point to the terminating fix/facility/landing area) will be written verbatim as provided by the procedure source document. Exception will be MEAs shown within parentheses and nautical mile distances. These will be considered graphic instructions and not included in the written description.

When Arrival procedures are the same for parallel runways, they will be listed in the order left, center, right, e.g., 18L/C/R. When multiple runway ends are shown for the same arrival procedure, they will be listed in numerical order from 1 to 36.

If transitions exist on the non-RNAV STAR, the arrival text shall begin with “....” to represent a lead-in from the transition text. See [Appendix 5](#).

On both RNAV and non-RNAV charts, if the common arrival text is further broken down into multiple landing descriptions, the “thence....” format may be used if necessary.

3.5.2.3 Lost Communication Text

Lost communication procedure(s) will be written verbatim following the arrival text if provided by the procedure source document. Exception will be holding instructions provided within parentheses (e.g., hold E, right turns, 270 degrees inbound). These will be considered graphic instructions and not included in the written description. See [Appendix 6](#).

When procedures are the same for parallel runways, they will be listed in the order left, center, right, e.g., 18L/C/R. When multiple runway ends are shown for the same procedure, they will be listed in numerical order from 1 to 36.

APPENDIX 1 LEGEND

LEGEND 00000 STANDARD TERMINAL ARRIVAL (STAR) CHARTS

RADIO AIDS TO NAVIGATION

Compulsory:

- VOR VORTAC DME NDB/DME
- VOR/DME TACAN NDB

Non-Compulsory:

- VOR VORTAC DME
- VOR/DME TACAN NDB NDB/DME

LMM, LOM (Compass locator) Marker Beacon

Localizer Front Course Localizer Back Course (Shading on left)

SDF Course

(T) indicates frequency protection range (Y) TACAN must be placed in "Y" mode to receive distance information

Frequency: 112.25 (T) ORL : --- Chan 59(Y)

ORLANDO ORL : --- Chan 59(Y)

Underline indicates no voice transmitted on this frequency DME or TACAN Channel

FIXES/ATC REPORTING REQUIREMENTS

Reporting Points
N00°00.00'
W00°00.00'

- ▲ Fix-Compulsory and → DME fix
- △ Non-Compulsory Position Report
- Obvious DME (DME mileage matches route mileage) 75 → DME Mileage (when not obvious)
- ◆ WAYPOINT (Compulsory) ◆ WAYPOINT (Non-Compulsory)
- ⬠ FLYOVER POINT
- X Computer Navigation Fix (CNF) - No ATC Function (JEHNN)
N00°00.00'
W00°00.00'

AIRPORTS

⊙ Civil ⊙ Military ⊙ Joint (Civil-Military)

Airports not served by the procedure shown in screened color

⊙ Civil ⊙ Military ⊙ Joint (Civil-Military)

ROUTES

MAA FL200 Maximum Authorized Altitude
4500 MEA-Minimum Enroute Altitude
*3500 MOCA-Minimum Obstruction Clearance Altitude

← 270° Arrival Route
(65) Mileage between Radio Aids, Reporting Points, and Route Breaks

← Transition Route

← R-275 Radial line and value

⋯ Lost Communications Track

V12 J80 Airway/Jet Route Identification

(IAS) Holding Pattern ⋯ Lost Comm Holding Pattern

Holding pattern with max. restricted airspeed (175K) applies to all altitudes (210K) applies to altitudes above 6000' to and including 14000'

SPECIAL USE AIRSPACE

R-352 R-Restricted W-Warning
P-Prohibited A-Alert
MOA-Military Operations Area

ALTITUDES

5500 2300 4800
Mandatory Altitude (Cross at) Minimum Altitude (Cross at or above) Maximum Altitude (Cross at or below)

15000 → Altitude change at other than Radio Aids to Navigation
12000
Block Altitude

INDICATED AIRSPEED

175K 120K 250K
Mandatory Airspeed Minimum Airspeed Maximum Airspeed

MISCELLANEOUS

┌ Changeover Point

⋯ Air Defense Identification Zone

N ↑ Indicates True North is not aligned to the top of the page

Ldg KLAS and KHND Terminus identifier
Ldg Rwys 16L/C/R

LEGEND 00000

**APPENDIX 2
PAGE LAYOUT**

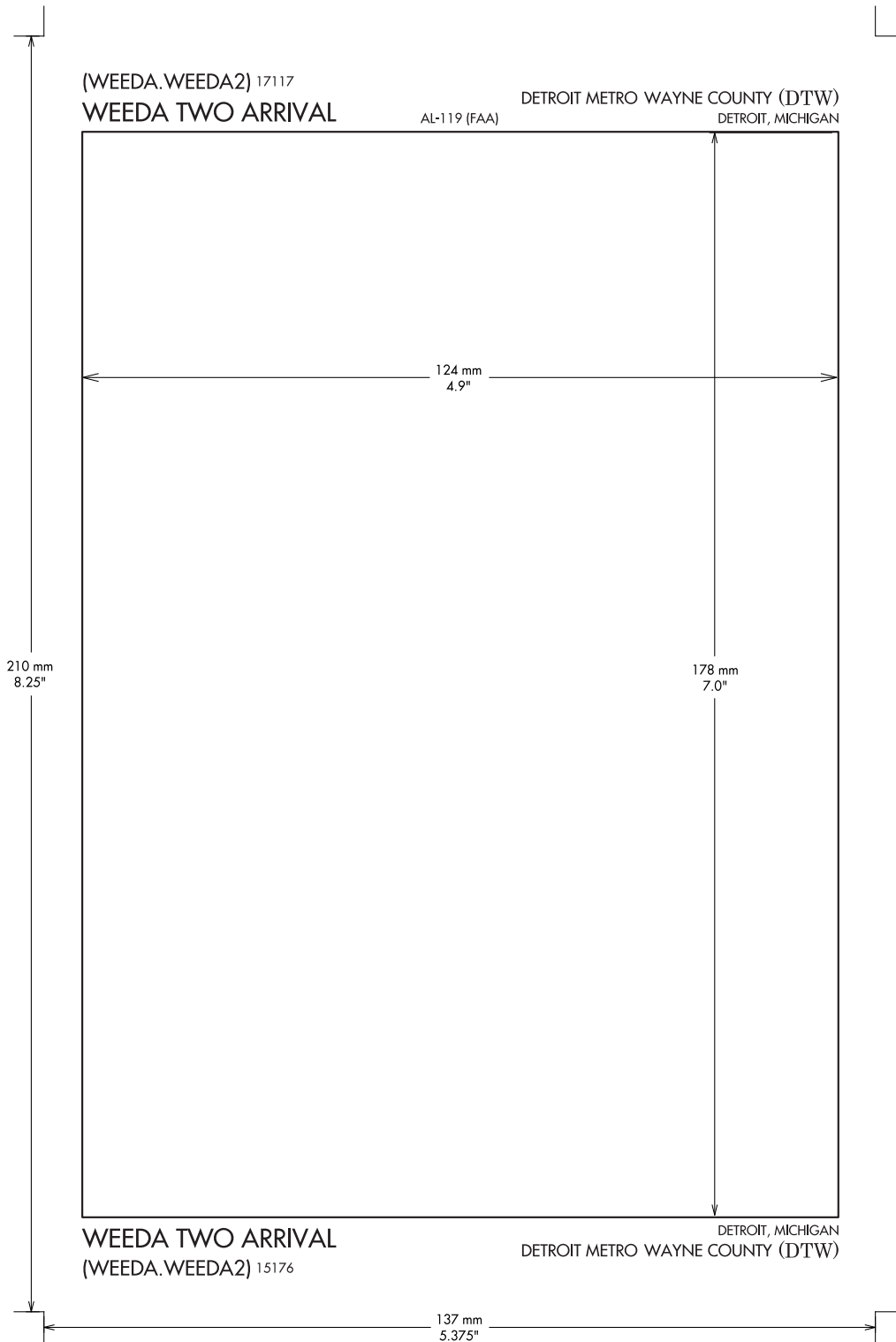

APPENDIX 3 EAST WEST PAGE LAYOUT

(CXR.CXR3) 17117

CHARDON THREE ARRIVAL

AL-84 (FAA)

CLEVELAND, OHIO

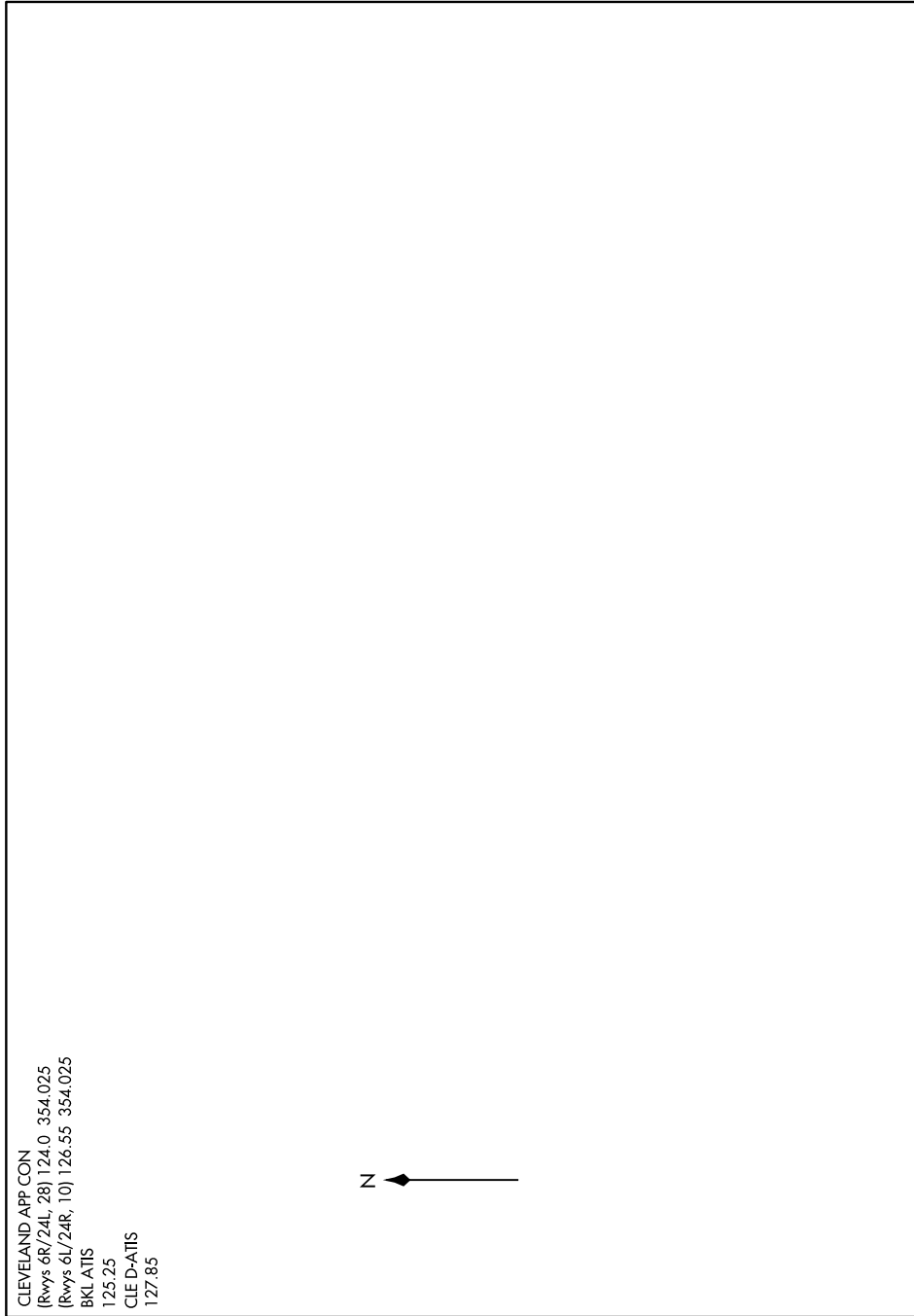

CHARDON THREE ARRIVAL

CLEVELAND, OHIO

(CXR.CXR3) 29MAY14

APPENDIX 4 MARGIN DATA

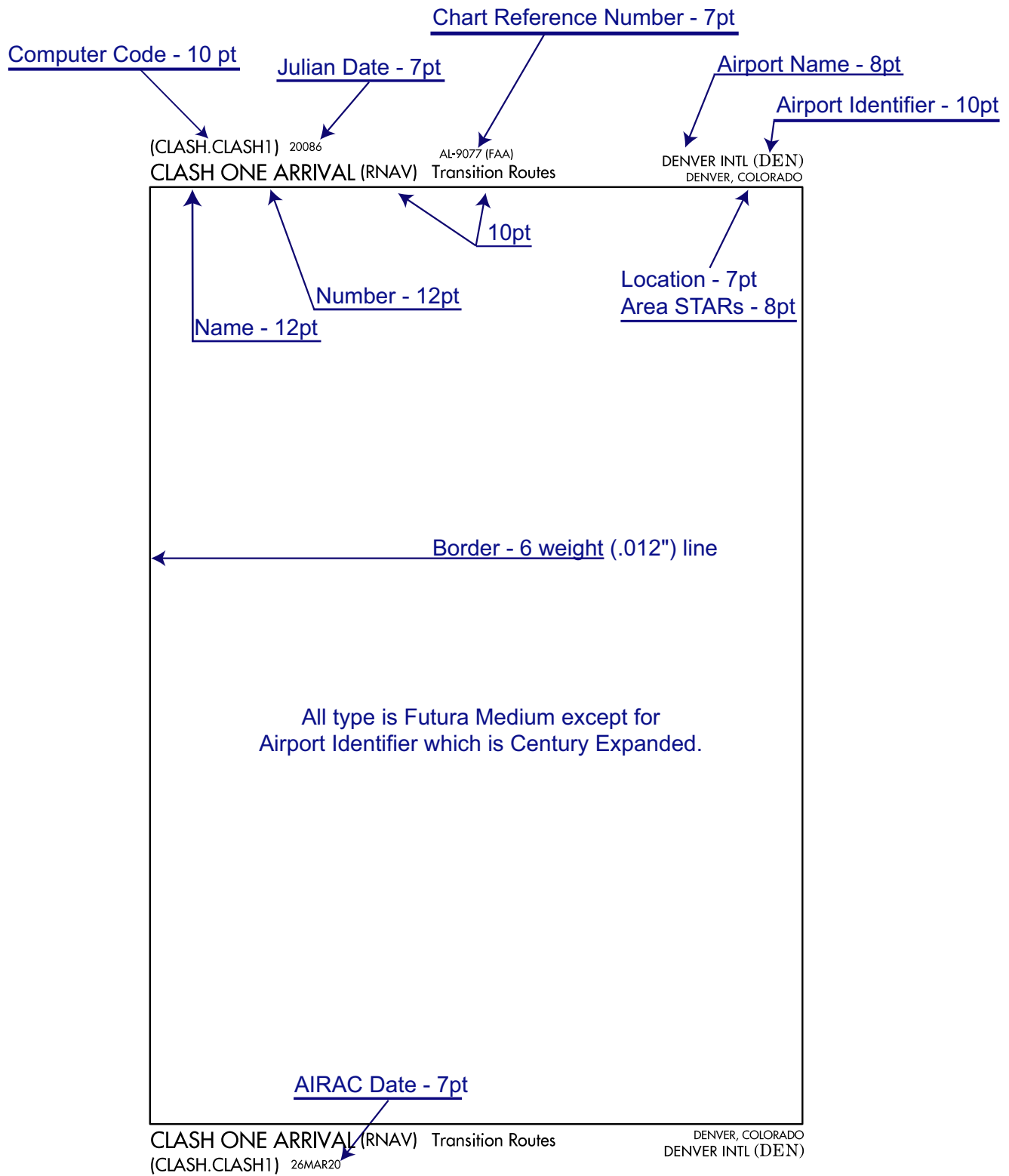

APPENDIX 5 STAR WITH TRANSITIONS

(QUAIL.QUAIL1) 23334

QUAIL ONE ARRIVAL

AL-9077 (FAA)

DENVER, COLORADO

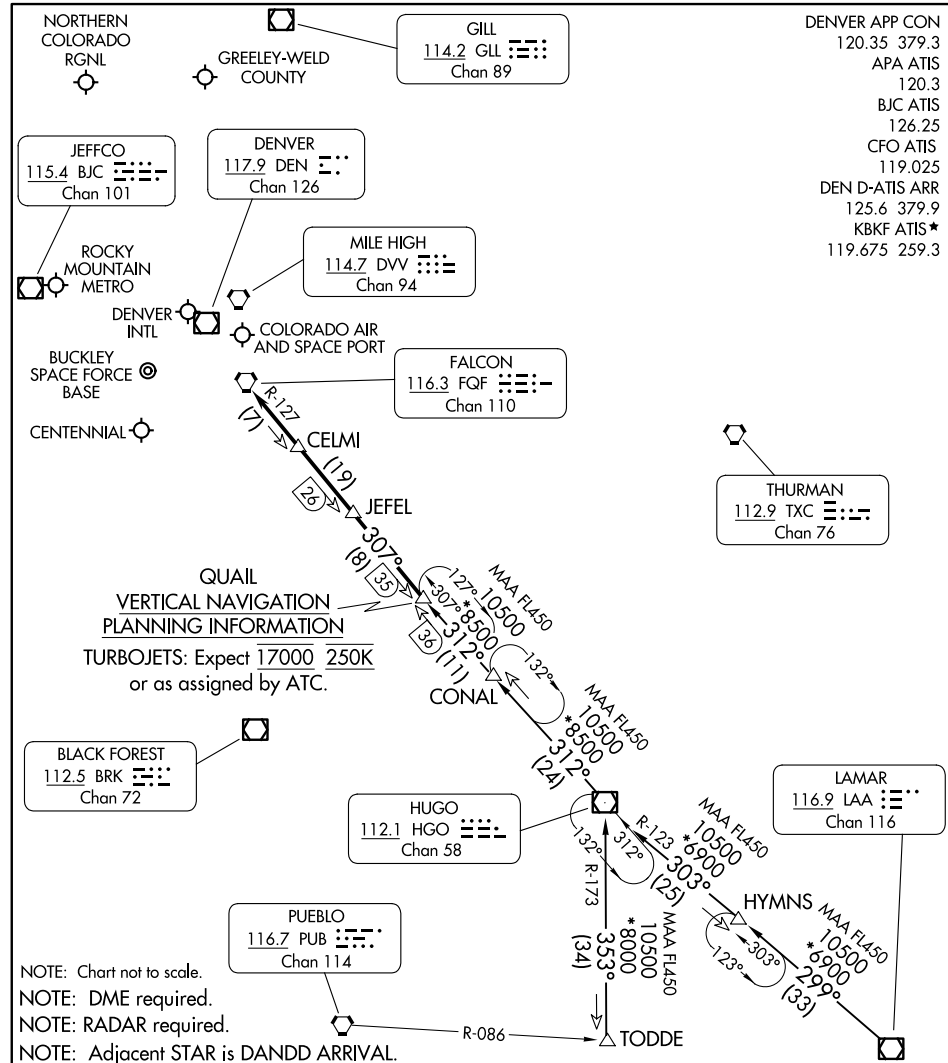

NOTE: Chart not to scale.
 NOTE: DME required.
 NOTE: RADAR required.
 NOTE: Adjacent STAR is DANDD ARRIVAL.

ARRIVAL ROUTE DESCRIPTION

HUGO TRANSITION (HGO.QUAIL1): From over HGO VOR/DME on HGO R-312 to QUAIL. Thence. . . .

LAMAR TRANSITION (LAA.QUAIL1): From over LAA VOR/DME on LAA R-299 and HGO R-123 to HGO VOR/DME, then on HGO R-312 to QUAIL. Thence. . . .

TODDE TRANSITION (TODDE.QUAIL1): From over TODDE on HGO R-173 to HGO VOR/DME, then on HGO R-312 to QUAIL. Thence. . . .

. . . .from over QUAIL on HGO R-312 and FQF R-127 to FQF VORTAC. Expect RADAR vectors to the final approach course at or before FQF VORTAC.

QUAIL ONE ARRIVAL

DENVER, COLORADO

(QUAIL.QUAIL1) 30JAN20

APPENDIX 6 STAR WITH ARRIVAL ONLY

(BVL.BVL2) 24025

BONNEVILLE TWO ARRIVAL

AL-365 (FAA)

SALT LAKE CITY INTL (SLC)
SALT LAKE CITY, UTAH

SALT LAKE CITY APP CON
128.6 322.3
D-ATIS 124.75 125.625

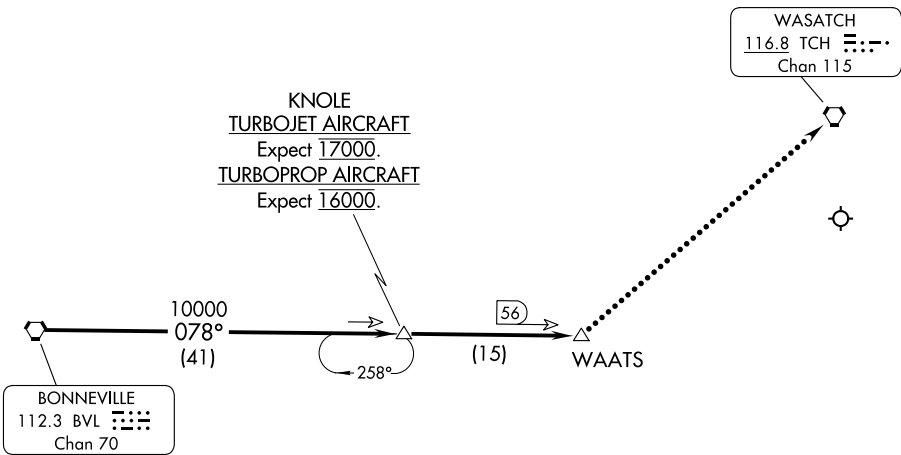

NOTE: DME required.
NOTE: Chart not to scale.

ARRIVAL ROUTE DESCRIPTION

From BVL VORTAC via BVL R-078 to WAATS, thence expect RADAR vectors to final approach course.

LOST COMMUNICATIONS: In the event of lost communications at WAATS, proceed direct TCH VORTAC. Maintain 13000' until TCH VORTAC.

BONNEVILLE TWO ARRIVAL

(BVL.BVL2) 31MAR16

SALT LAKE CITY, UTAH
SALT LAKE CITY INTL (SLC)

APPENDIX 8 AREA STAR

(GEP.GEP9) 17173

GOPHER NINE ARRIVAL

AL-264 (FAA)

MINNEAPOLIS, MINNESOTA

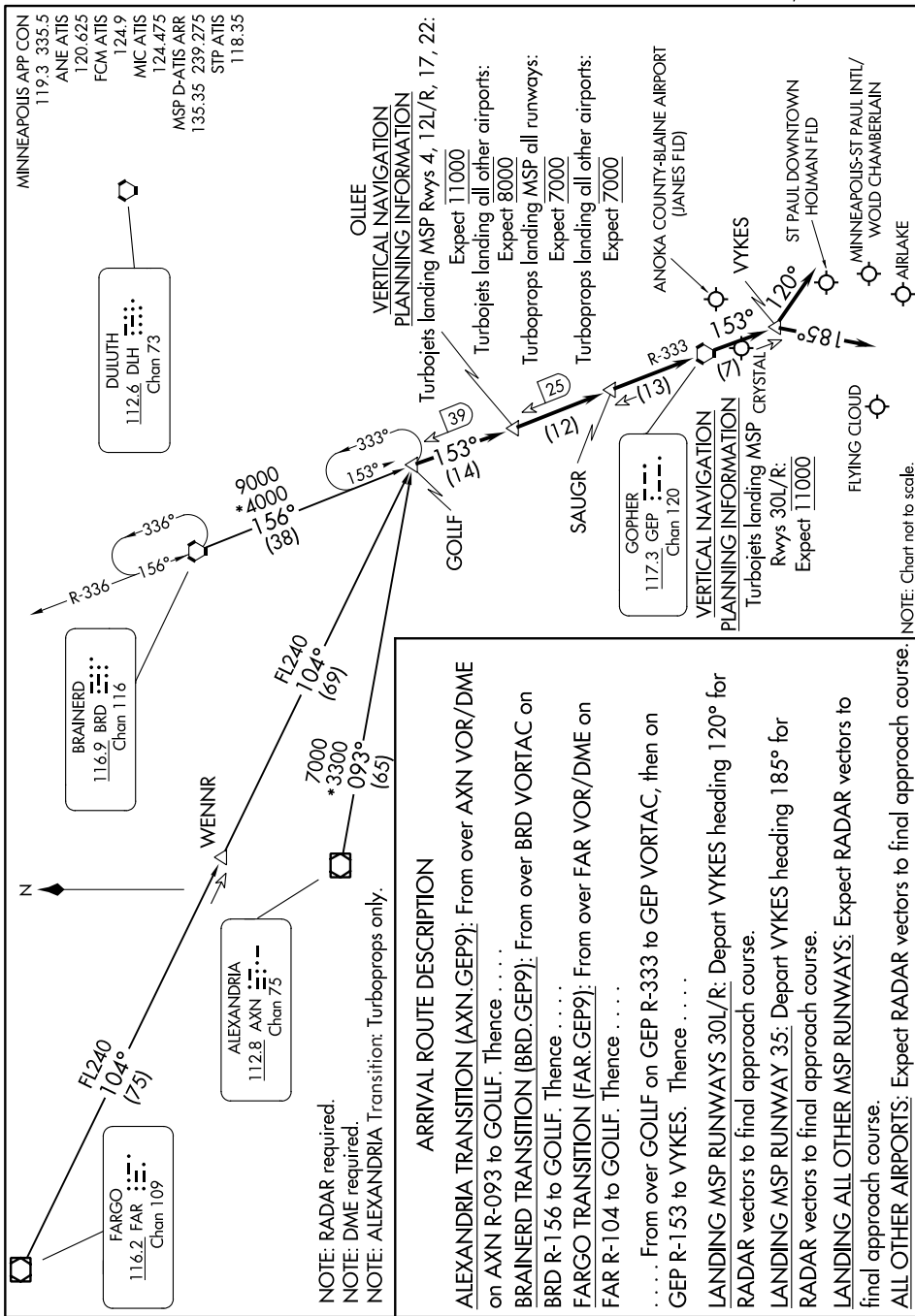

GOPHER NINE ARRIVAL

MINNEAPOLIS, MINNESOTA

(GEP.GEP9) 10NOV16

**APPENDIX 9
RNAV STAR**

(CEEME.CEEME5) 17117

CEEME FIVE ARRIVAL (RNAV)

AL-67 (FAA)

BOB HOPE (BUR)
BURBANK, CALIFORNIA

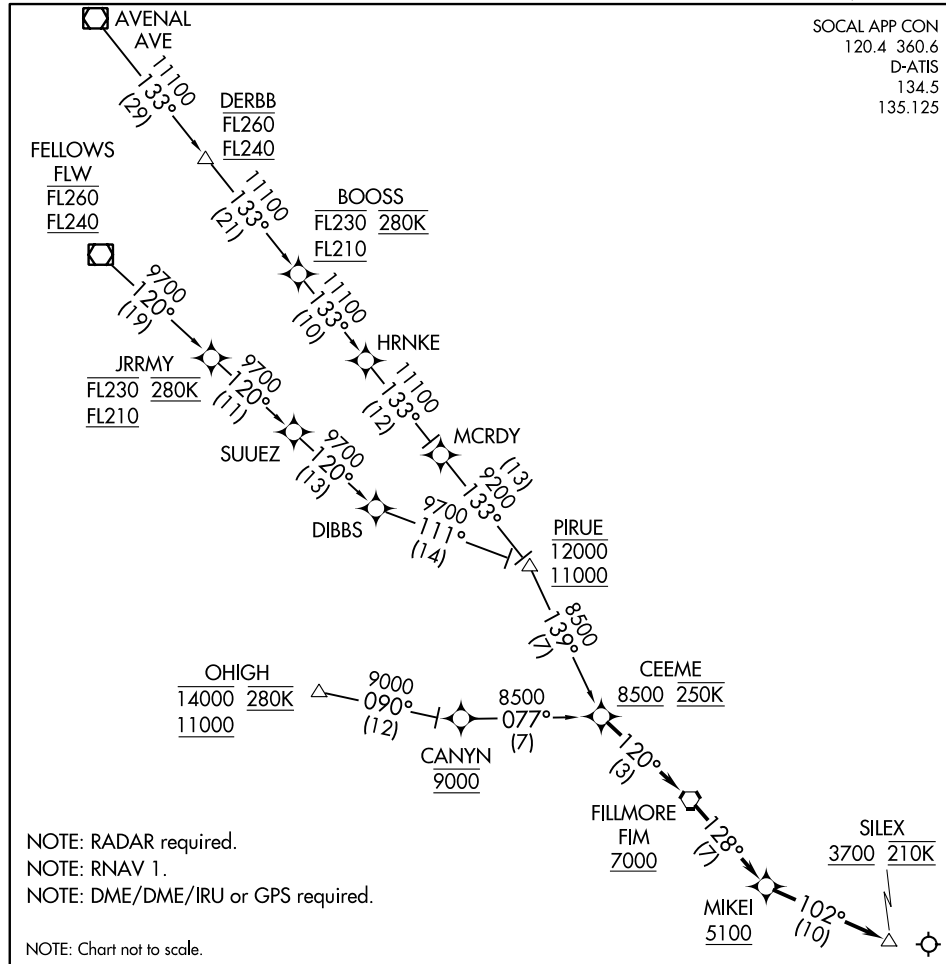

ARRIVAL ROUTE DESCRIPTION

AVENAL TRANSITION (AVE.CEEME5)

DERBB TRANSITION (DERBB.CEEME5)

FELLOWS TRANSITION (FLW.CEEME5)

OHIGH TRANSITION (OHIGH.CEEME5)

From CEEME on track 120° to cross FIM VORTAC at or above 7000, then on track 128° to cross MIKEI at or above 5100.

LANDING RUNWAY 8: From MIKEI on track 102° to cross SILEX at or above 3700 and at 210K. Expect ILS Z or LOC Z RWY 8 approach.

LOST COMMUNICATIONS

Join the Burbank ILS Z or LOC Z RWY 8 approach at SILEX.

CEEME FIVE ARRIVAL (RNAV)

(CEEME.CEEME5) 10NOV16

BURBANK, CALIFORNIA
BOB HOPE (BUR)

APPENDIX 10
STAR WITH CONTINUED PAGE (CONTINUED)

(BARET.BARET5) 17173

BARET FIVE ARRIVAL

AL-373 (FAA)

SAN DIEGO, CALIFORNIA

ARRIVAL ROUTE DESCRIPTION

IMPERIAL TRANSITION (IPL.BARET5): From over IPL VORTAC on IPL R-258 and MZB R-076 to BARET INT. Thence

NEEDLES TRANSITION (EED.BARET5): From over EED VORTAC on EED R-208 to SHADI INT, then on JLI R-040 to SALTN INT, then on PGY R-027 to CARUL INT, then on JLI R-177 to BARET INT. Thence

PARKER TRANSITION (PKE.BARET5): From over PKE VORTAC on PKE R-227 to SHADI INT, then on JLI R-040 to SALTN INT, then on PGY R-027 to CARUL INT, then on JLI R-177 to BARET INT. Thence

TWENTYNINE PALMS TRANSITION (TNP.BARET5): From over TNP VORTAC on TNP R-179 to MOMAR INT, then on JLI R-040 to SALTN INT, then on PGY R-027 to CARUL INT, then on JLI R-177 to BARET INT. Thence

. . . . LANDING SAN RWY 9: From BARET INT on PGY R-043 to PGY VORTAC, then on PGY R-270 to IFSOX, then on OCN R-162 to SARGS INT.

Expect ILS Rwy 9 approach to SAN or LOC/DME-B to NZY.

. . . . LANDING SAN RWY 27 and NZY: From BARET INT on PGY R-043 to IFHEJ, then on I-UBR localizer to VYDDA INT. Expect LOC Rwy 27 approach to SAN or LOC/DME-A to NZY.

LOST COMMUNICATIONS: In the event of lost communications, North Island arrivals shall execute the TACAN Rwy 29 or TACAN Rwy 36.

BARET FIVE ARRIVAL

SAN DIEGO, CALIFORNIA

(BARET.BARET5) 08JAN15

APPENDIX 11 CONVENTIONAL STAR WITH RNAV WAYPOINTS

(GRAYM.GRAYM6) 23334
GRAYM SIX ARRIVAL

AL-626 (FAA)

BEDFORD, MASSACHUSETTS

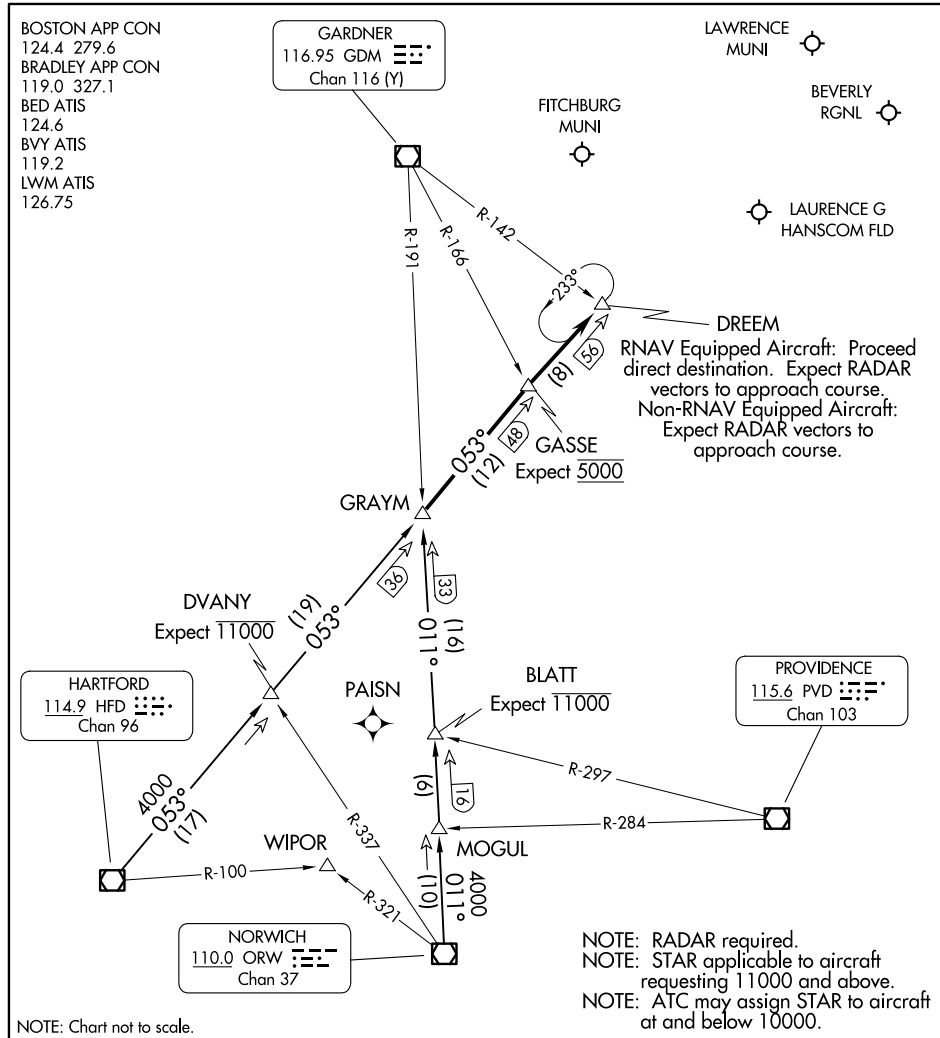

NOTE: Chart not to scale.

ARRIVAL ROUTE DESCRIPTION

HARTFORD TRANSITION (HFD.GRAYM6): From over HFD VOR/DME on HFD R-053 to GRAYM. Thence. . . .

NORWICH TRANSITION (ORW.GRAYM6): From over ORW VOR/DME on ORW R-011 to GRAYM. Thence. . . .

. . . . From over GRAYM on HFD R-053 to GASSE, then to DREEM, at DREEM:
RNAV EQUIPPED AIRCRAFT: Proceed direct destination expect radar vectors to approach course.
NON-RNAV EQUIPPED AIRCRAFT: Expect radar vectors to approach course.

GRAYM SIX ARRIVAL
(GRAYM.GRAYM6) 08NOV18

BEDFORD, MASSACHUSETTS

APPENDIX 12 STAR WITH CAUTION NOTE

(MIERA.MIERA2) 20366

MIERA TWO ARRIVAL

AL-12 (FAA)

ALBUQUERQUE, NEW MEXICO

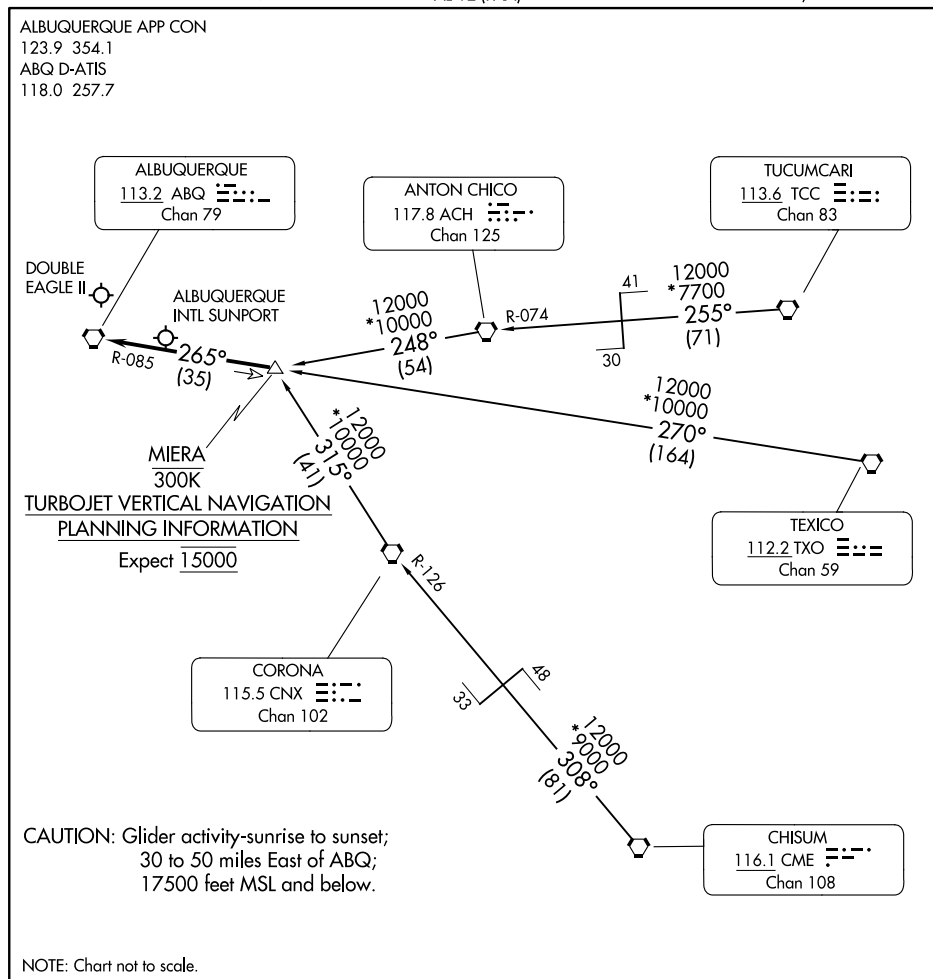

ARRIVAL ROUTE DESCRIPTION

CHISUM TRANSITION (CME.MIERA2): From over CME VORTAC via CME R-308 and CNX R-126 to CNX VORTAC, then via CNX R-315 to MIERA DME fix. Thence. . .

TEXICO TRANSITION (TXO.MIERA2): From over TXO VORTAC via TXO R-270 and ABQ R-085 to MIERA DME fix. Thence. . .

TUCUMCARI TRANSITION (TCC.MIERA2): From over TCC VORTAC via TCC R-255 and ACH R-074 to ACH VORTAC, then via ACH R-248 to MIERA DME fix. Thence. . .

. . . From over MIERA DME fix via ABQ R-085 to ABQ VORTAC. Expect vectors to final approach course after passing MIERA DME fix.

MIERA TWO ARRIVAL

ALBUQUERQUE, NEW MEXICO

(MIERA.MIERA2) 11NOV93

APPENDIX 13 STAR WITH OFFSET TEXT BOX

(TRAPR.TRAPR2) 13178

TRAPR TWO ARRIVAL (RNAV)

AL-640 (FAA)

SARASOTA/BRADENTON, FLORIDA

TAMPA APP CON
119.65 353.575
SRQ ATIS
124.375
VNC AWOS-3
119.275

ARRIVAL ROUTE DESCRIPTION

TAYLOR TRANSITION (TAY.TRAPR2):

From TRAPR on track 177° to ZEBON, then on track 177° to RUNNE, then on track 177° to LAL VORTAC. Thence . . .

. . . . KSRQ Landing Rwy 14: From over LAL VORTAC on track 226° to WUDDY, then on track 226° to LYFIE, then on track 273° to RUTAE, then on 230° heading. Expect radar vectors.

. . . . KSRQ Landing Rwy 32: From over LAL VORTAC on track 226° to WUDDY, then on track 226° to LYFIE, then on track 175° to MURDO, then on 230° heading. Expect radar vectors.

. . . . KVNC: From over LAL VORTAC on track 226° to WUDDY, then on track 226° to LYFIE, then on heading 226°. Expect radar vectors.

LOST COMMUNICATIONS:

KSRQ Landing Rwy 14: Continue track to RUTAE, then turn left to intercept the Rwy 14 final approach course, conduct approach.

KSRQ Landing Rwy 32: Continue track to MURDO, then turn right to intercept the Rwy 32 final approach course, conduct approach.

KVNC: Standard.

- NOTE: DME/DME/IRU or GPS Required.
- NOTE: RNAV 1.
- NOTE: Radar Required.
- NOTE: Turbojet and Turboprop aircraft only.

NOTE: Chart not to scale.

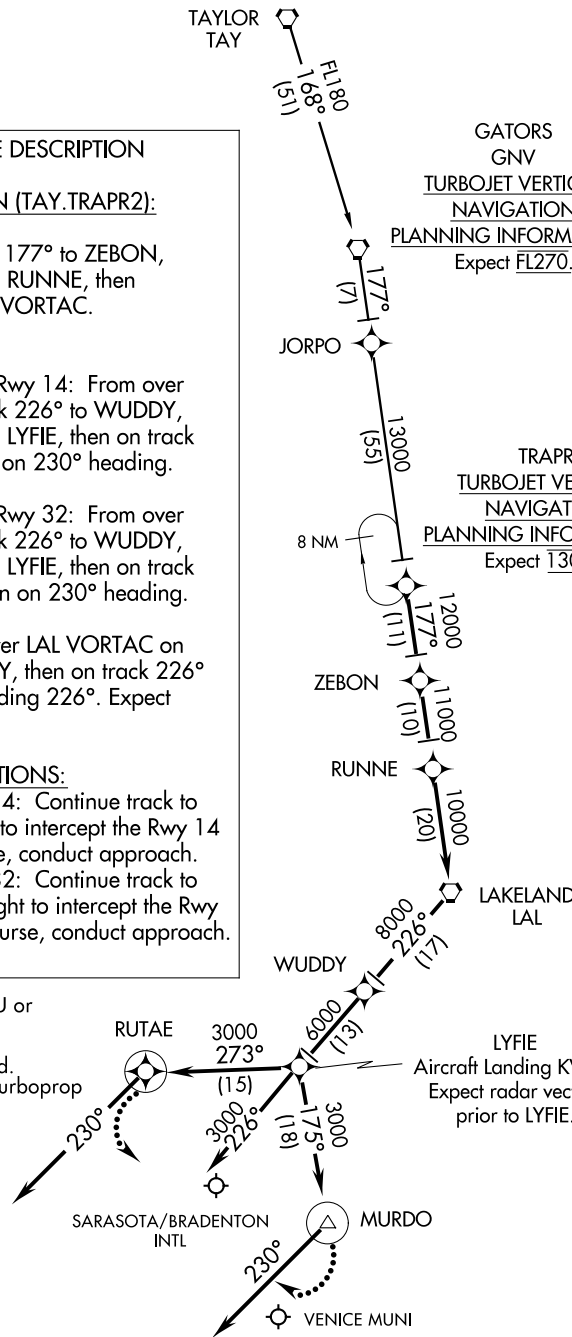

GATORS
GNV
TURBOJET VERTICAL NAVIGATION
PLANNING INFORMATION:
Expect FL270.

TRAPR
TURBOJET VERTICAL NAVIGATION
PLANNING INFORMATION:
Expect 13000.

LYFIE
Aircraft Landing KVNC:
Expect radar vectors prior to LYFIE.

TRAPR TWO ARRIVAL (RNAV)

SARASOTA/BRADENTON, FLORIDA

(TRAPR.TRAPR2) 13178

APPENDIX 14 PBN/EQUIPMENT REQUIREMENTS NOTE BOX

(KROTO.KROTO5) 24305

KROTO FIVE ARRIVAL (RNAV)

TED STEVENS ANCHORAGE INTL (ANC)(PANC)
AL-1500 (FAA) ANCHORAGE, ALASKA

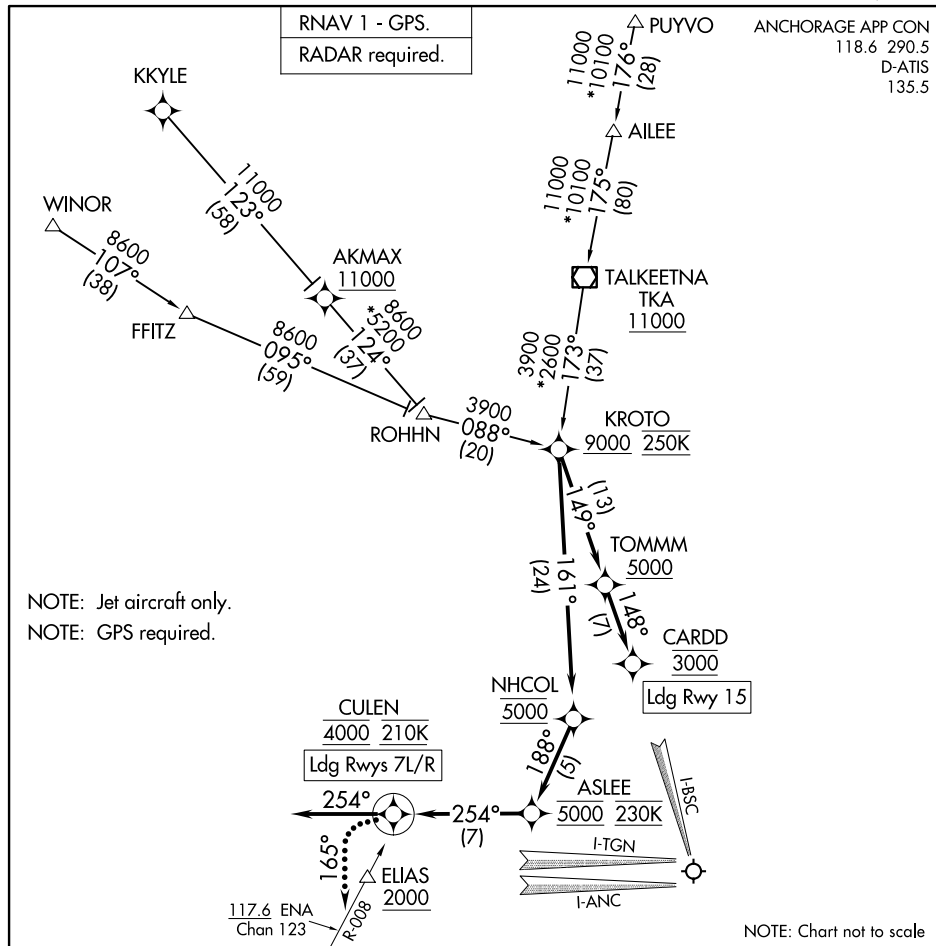

ARRIVAL ROUTE DESCRIPTION

KYLE TRANSITION (KYLE.KROTO5)

PUYVO TRANSITION (PUYVO.KROTO5)

WINOR TRANSITION (WINOR.KROTO5)

LANDING RUNWAYS 7L/R: From KROTO on track 161° to cross NHCOL at 5000, then on track 188° to cross ASLEE at 5000 and at 230K, then on track 254° to cross CULEN at 4000 and at 210K, then on track 254°. Expect RADAR vectors to final approach course.

LANDING RUNWAY 15: From KROTO on track 149° to cross TOMMM at or above 5000, then on track 148° to cross CARDD at 3000. Expect ILS or RNAV RWY 15 approach.

LOST COMMUNICATIONS

RUNWAYS 7L/R: After CULEN, turn left heading 165°, intercept the ENA VOR/DME R-008 to cross ELIAS at or above 2000 and proceed on the ILS or LOC RWY 7R approach.

RUNWAY 15: After CARDD proceed on the ILS RWY 15 approach.

KROTO FIVE ARRIVAL (RNAV)

(KROTO.KROTO5) 31OCT24

ANCHORAGE, ALASKA
TED STEVENS ANCHORAGE INTL (ANC)(PANC)

APPENDIX 15 MULTIPLE GRAPHIC STAR (2 PAGES)

(EURO.OOSH5) 24305

AL-58 (FAA)

GENERAL EDWARD LAWRENCE LOGAN INTL (BOS)

OOSH5 FIVE ARRIVAL (RNAV) Transition Routes

BOSTON, MASSACHUSETTS

D-ATIS
135.0
BOSTON APP CON
120.6 263.1

NOTE: RADAR required.
NOTE: RNAV 1.
NOTE: DME/DME/IRU or GPS required.
NOTE: Turbojet aircraft only.
NOTE: FEXXX, MERIT, PROVI, RIFLE transitions assigned by ATC only.

- AJJAY TRANSITION (AJJAY.OOSH5)
- FERNZ TRANSITION (FERNZ.OOSH5)
- FEXXX TRANSITION (FEXXX.OOSH5)
- KENNEBUNK TRANSITION (ENE.OOSH5)
- MERIT TRANSITION (MERIT.OOSH5)
- PROVI TRANSITION (PROVI.OOSH5)
- RIFLE TRANSITION (RIFLE.OOSH5)

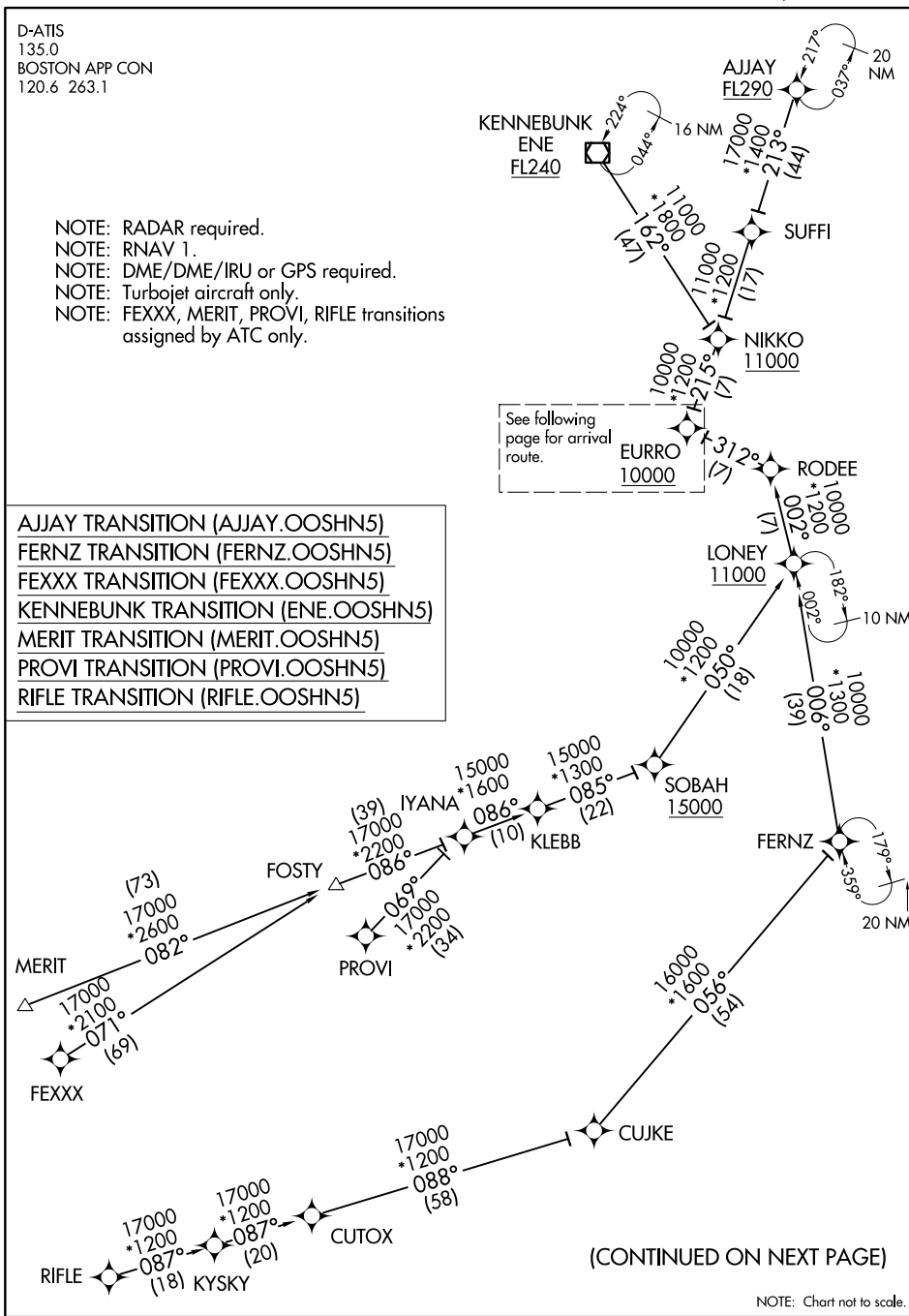

OOSH5 FIVE ARRIVAL (RNAV) Transition Routes

BOSTON, MASSACHUSETTS

(EURO.OOSH5) 12OCT17

GENERAL EDWARD LAWRENCE LOGAN INTL (BOS)

**APPENDIX 15
MULTIPLE GRAPHIC STAR (2 PAGES) (CONTINUED)**

(EURRO.OOSH5) 17285 AL-58 (FAA)
GENERAL EDWARD LAWRENCE LOGAN INTL (BOS)
OOSH5 FIVE ARRIVAL (RNAV) Arrival Routes BOSTON, MASSACHUSETTS

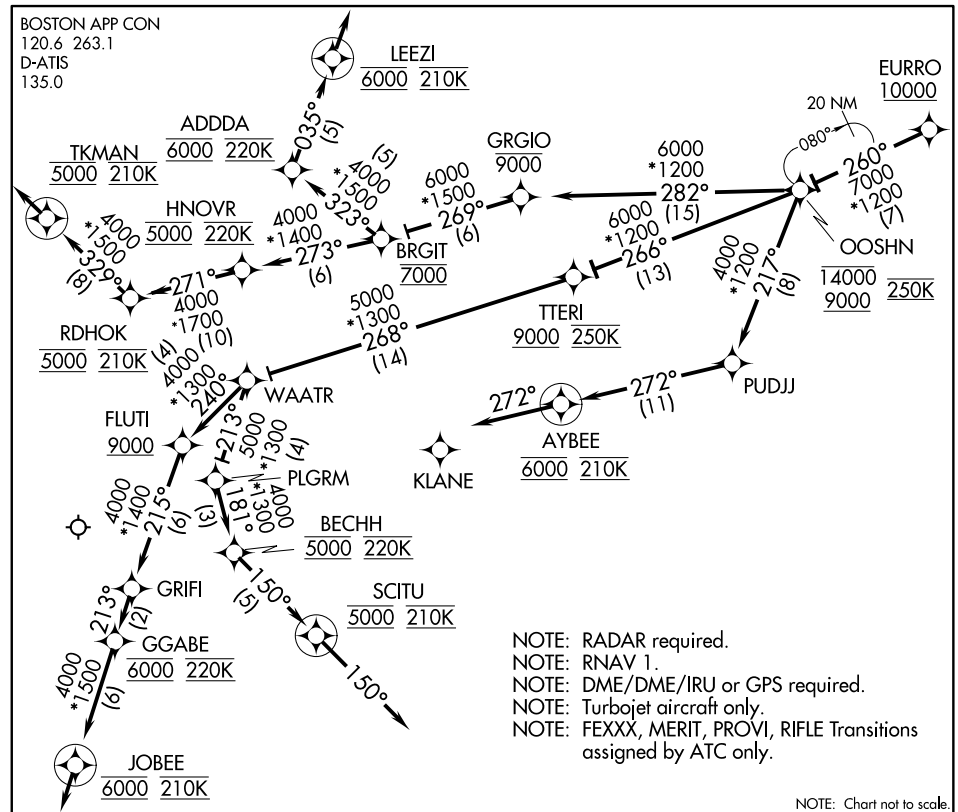

ARRIVAL ROUTE DESCRIPTION

From EURRO on track 260° to cross OOSH5 between 9000 and 14000 and at 250K.

LANDING RWYS 4L/R: From OOSH5 on track 266° to cross TTERI at or above 9000 and at 250K, then on track 268° to WAATR, then on track 240° to cross FLUTI at or above 9000, then on track 215° to GRIFI, then on track 213° to cross GGABE at 6000 and at 220K, then on track 213° to cross JOBEE at 6000 and at 210K, then on track 213°. Expect RADAR vectors to final approach course.

LANDING RWY 15R: From OOSH5 on track 282° cross GRGIO at or below 9000, then on track 269° to cross BRGIT at 7000, then on track 273° to cross HNOVR at 5000 and at 220K, then on track 271° to cross RDHOK at 5000 and at 210K, then on track 329° to cross TKMAN at 5000 and at 210K, then on track 329°. Expect RADAR vectors to final approach course.

LANDING RWYS 22L/R: From OOSH5 on track 282° to cross GRGIO at or below 9000, then on track 269° to cross BRGIT at 7000, then on track 323° to cross ADDDA at 6000 and at 220K, then on track 035° to cross LEEZI at 6000 and at 210K, then on track 035°. Expect RADAR vectors to final approach course.

LANDING RWY 27: From OOSH5 on track 217° to PUDJJ, then on track 272° to cross AYBEE at 6000 and at 210K, then on track 272°. Expect RADAR vectors to final approach course.

LANDING RWYS 32, 33L: From OOSH5 on track 266° to cross TTERI at or above 9000 at at 250K, then on track 268° to WAATR, then on track 213° to PLGRM, then on track 181° to cross BECHH at 5000 and at 220K, then on track 150° to cross SCITU at 5000 and at 210K, then on track 150°. Expect RADAR vectors to final approach course.

OOSH5 FIVE ARRIVAL (RNAV) Arrival Routes BOSTON, MASSACHUSETTS
(EURRO.OOSH5) 12OCT17 GENERAL EDWARD LAWRENCE LOGAN INTL (BOS)

APPENDIX 16
 MULTIPLE GRAPHIC STAR (3 PAGES)

(EAGUL.EAGUL6) 17117

AL-322 (FAA)

PHOENIX SKY HARBOR INTL (PHX)

EAGUL SIX ARRIVAL (RNAV) Transition Routes

PHOENIX, ARIZONA

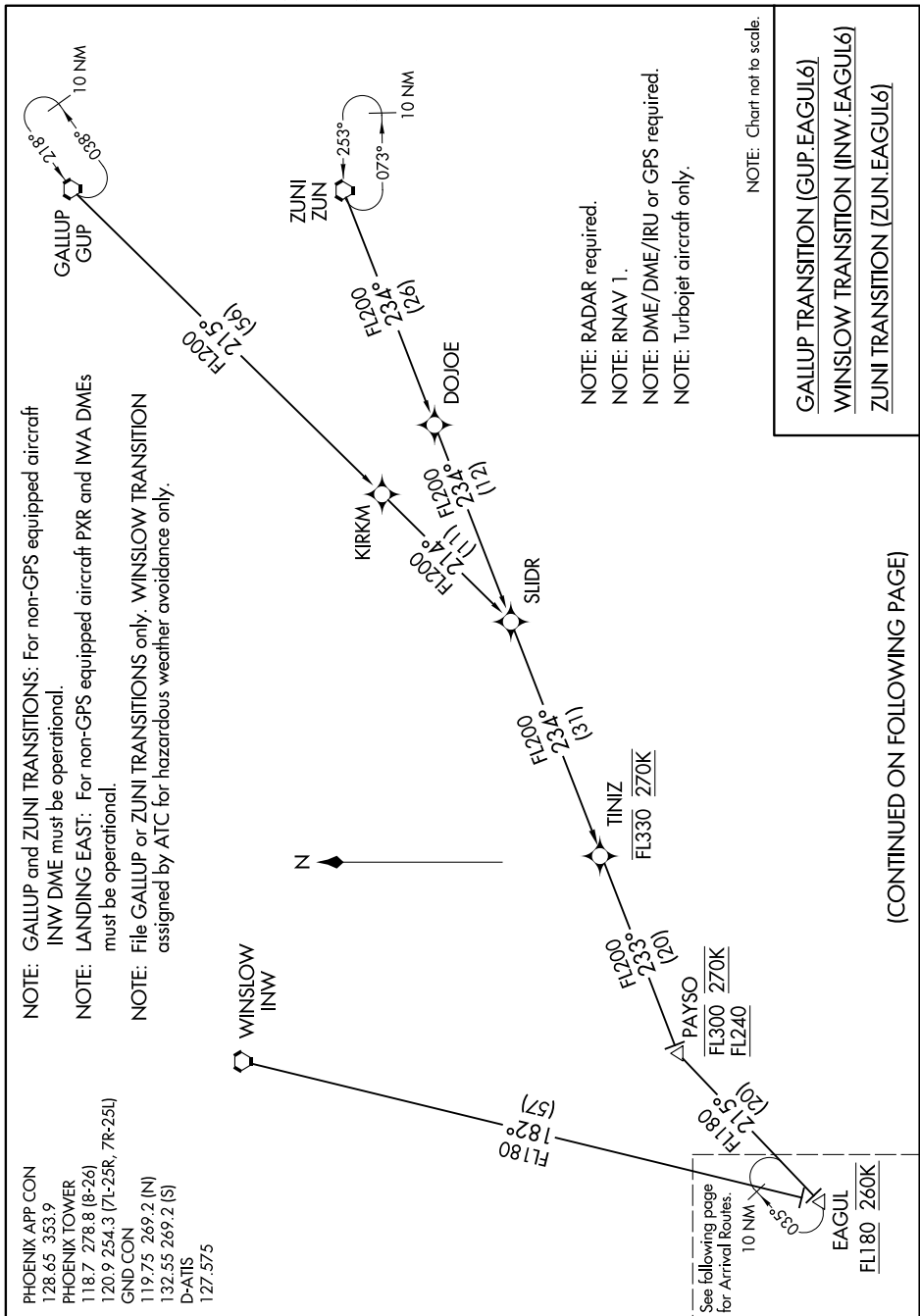

EAGUL SIX ARRIVAL (RNAV) Transition Routes

PHOENIX, ARIZONA

PHOENIX SKY HARBOR INTL (PHX)

(EAGUL.EAGUL6) 18SEP14

APPENDIX 16
MULTIPLE GRAPHIC STAR (3 PAGES) (CONTINUED)

(EAGUL.EAGUL6) 17117

AL-322 (FAA)

PHOENIX SKY HARBOR INTL (PHX)
PHOENIX, ARIZONA

EAGUL SIX ARRIVAL (RNAV) Arrival Routes

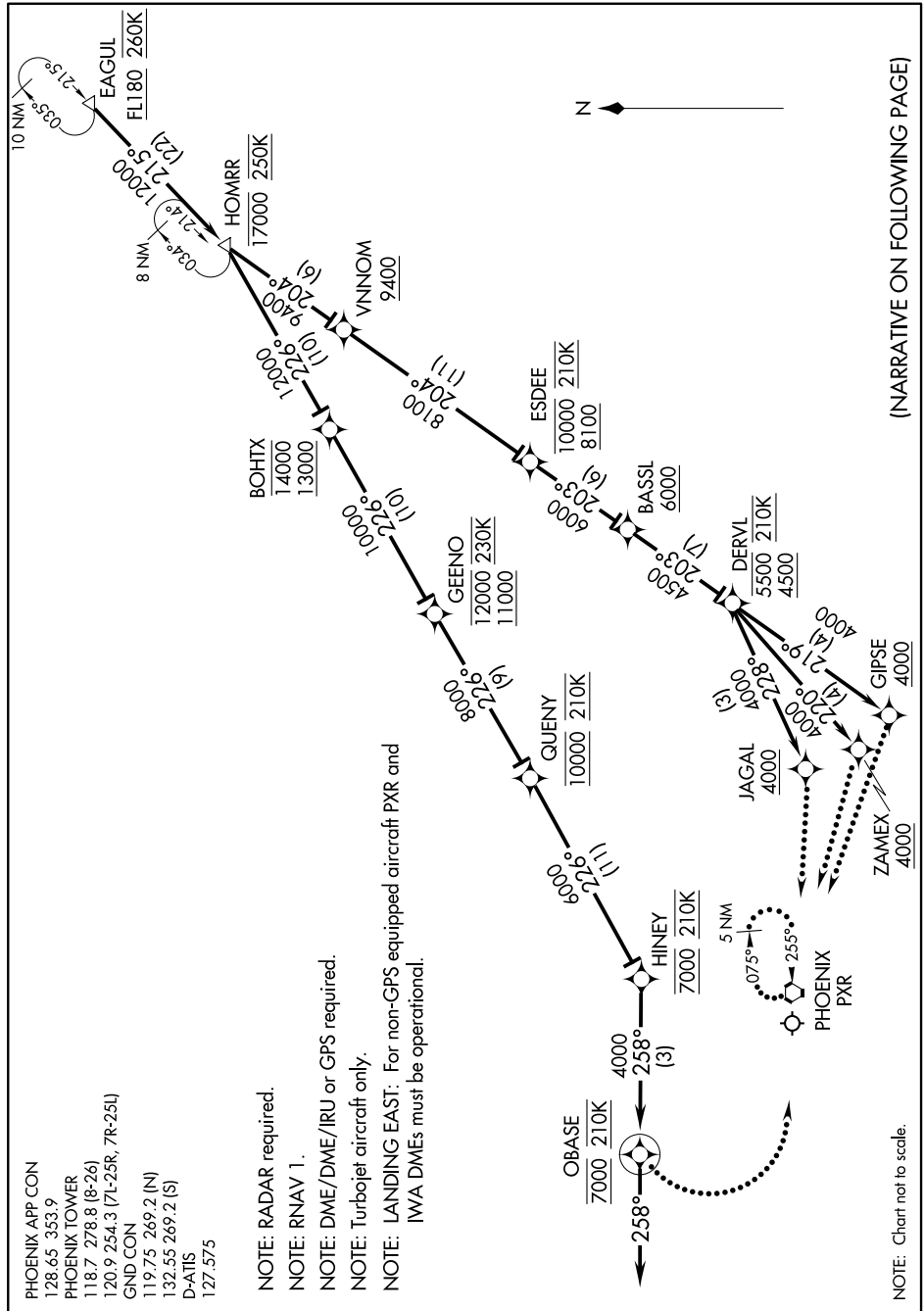

EAGUL SIX ARRIVAL (RNAV) Arrival Routes

(EAGUL.EAGUL6) 18SEP14

APPENDIX 16
MULTIPLE GRAPHIC STAR (3 PAGES) (CONTINUED)

(EAGUL.EAGUL6) 17117

EAGUL SIX ARRIVAL (RNAV)

AL-322 (FAA)

PHOENIX SKY HARBOR INTL (PHX)
PHOENIX, ARIZONA

ARRIVAL ROUTE DESCRIPTION

From EAGUL on track 215° to cross HOMRR at or below 17000 at 250K.

LANDING RUNWAYS 7L, 7R, 8: From HOMRR on track 226° to cross BOHTX at/above 13000 and at/below 14000, then on track 226° to cross GEENO at/above 11000 and at/below 12000 and at 230K, then on track 226° to cross QUENY at 10000 and at 210K, then on track 226° to cross HINEY at 7000 and at 210K, then on track 258° to cross OBASE at 7000 and at 210K, then on track 258°. Expect RADAR vectors to final approach course.

LANDING RUNWAY 25L: From HOMRR on track 204° to cross VNNOM at/above 9400, then on track 204° to cross ESDEE at/above 8100 and at/below 10000 and at 210K, then on track 203° to cross BASSL at/above 6000, then on track 203° to cross DERVL at/above 4500 and at/below 5500 and at 210K, then on track 219° to cross GIPSE at/above 4000. Expect ILS or LOC RWY 25L approach or RADAR vectors to final approach course.

LANDING RUNWAY 25R: From HOMRR on track 204° to cross VNNOM at/above 9400, then on track 204° to cross ESDEE at/above 8100 and at/below 10000 and at 210K, then on track 203° to cross BASSL at/above 6000, then on track 203° to cross DERVL at/above 4500 and at/below 5500 and at 210K, then on track 220° to cross ZAMEX at/above 4000. Expect RNAV (GPS) Y RWY 25R approach or RADAR vectors to final approach course.

LANDING RUNWAY 26: From HOMRR on track 204° to cross VNNOM at/above 9400, then on track 204° to cross ESDEE at/above 8100 and at/below 10000 and at 210K, then on track 203° to cross BASSL at/above 6000, then on track 203° to cross DERVL at/above 4500 and at/below 5500 at 210K, then on track 228° to cross JAGAL at/above 4000. Expect ILS or LOC RWY 26 approach or RADAR vectors to final approach course.

LOST COMMUNICATIONS

LANDING RUNWAY 7L: After OBASE turn left, intercept and execute RWY 7L ILS approach. If unable, proceed direct PXR VORTAC and hold, maintain 9000.

LANDING RUNWAY 7R: After OBASE turn left, intercept and execute RWY 7R ILS approach. If unable, proceed direct PXR VORTAC and hold, maintain 9000.

LANDING RUNWAY 8: After OBASE turn left, intercept and execute RWY 8 ILS approach. If unable, proceed direct PXR VORTAC and hold, maintain 9000.

LANDING RUNWAY 25L: At GIPSE, intercept and execute RWY 25L ILS approach. If unable, proceed direct PXR VORTAC and hold, maintain 9000.

LANDING RUNWAY 25R: At ZAMEX, intercept and execute RWY 25R RNAV (GPS) approach. If unable, proceed direct PXR VORTAC and hold, maintain 9000.

LANDING RUNWAY 26: At JAGAL, intercept and execute RWY 26 ILS approach. If unable, proceed direct PXR VORTAC and hold, maintain 9000.

EAGUL SIX ARRIVAL (RNAV)

(EAGUL.EAGUL6) 18SEP14

PHOENIX, ARIZONA
PHOENIX SKY HARBOR INTL (PHX)

**APPENDIX 17
TERMINUS IDENTIFICATION BOX - RUNWAY TERMINUS**

(HAWKZ.HAWKZ7) 18256

AL-582 (FAA)

HAWKZ SEVEN ARRIVAL (RNAV) Arrival Routes

SEATTLE-TACOMA INTL (SEA)
SEATTLE, WASHINGTON

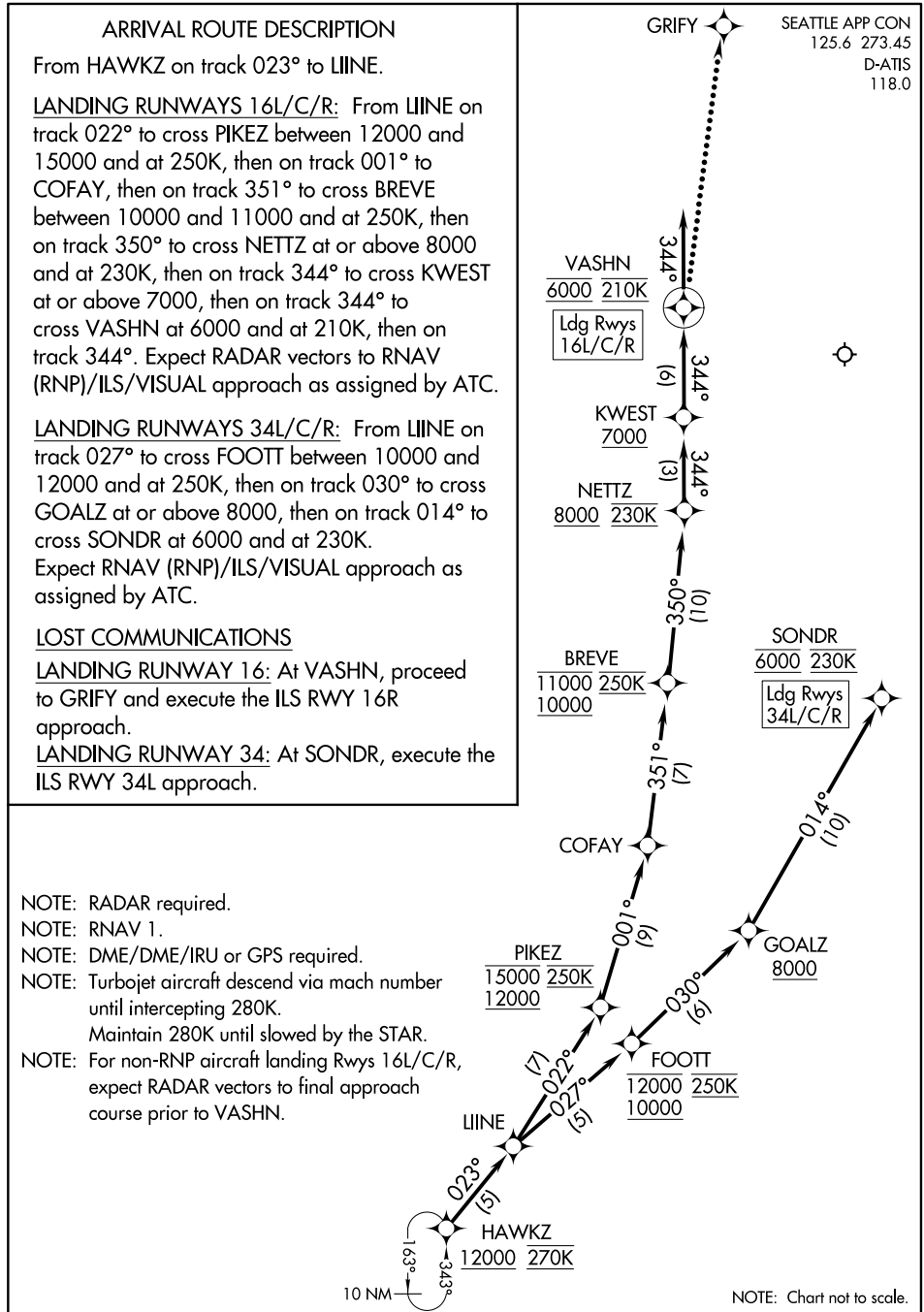

- NOTE: RADAR required.
- NOTE: RNAV 1.
- NOTE: DME/DME/IRU or GPS required.
- NOTE: Turbojet aircraft descend via mach number until intercepting 280K. Maintain 280K until slowed by the STAR.
- NOTE: For non-RNP aircraft landing Rwy 16L/C/R, expect RADAR vectors to final approach course prior to VASHN.

HAWKZ SEVEN ARRIVAL (RNAV) Arrival Routes

(HAWKZ.HAWKZ7) 13SEP18

SEATTLE, WASHINGTON
SEATTLE-TACOMA INTL (SEA)

APPENDIX 18 TERMINUS IDENTIFICATION BOX - AIRPORT TERMINUS

(HUUVR.HUUVR1) 19227

AL-638 (FAA)

HUUVR ONE ARRIVAL (RNAV)

AKRON, OHIO

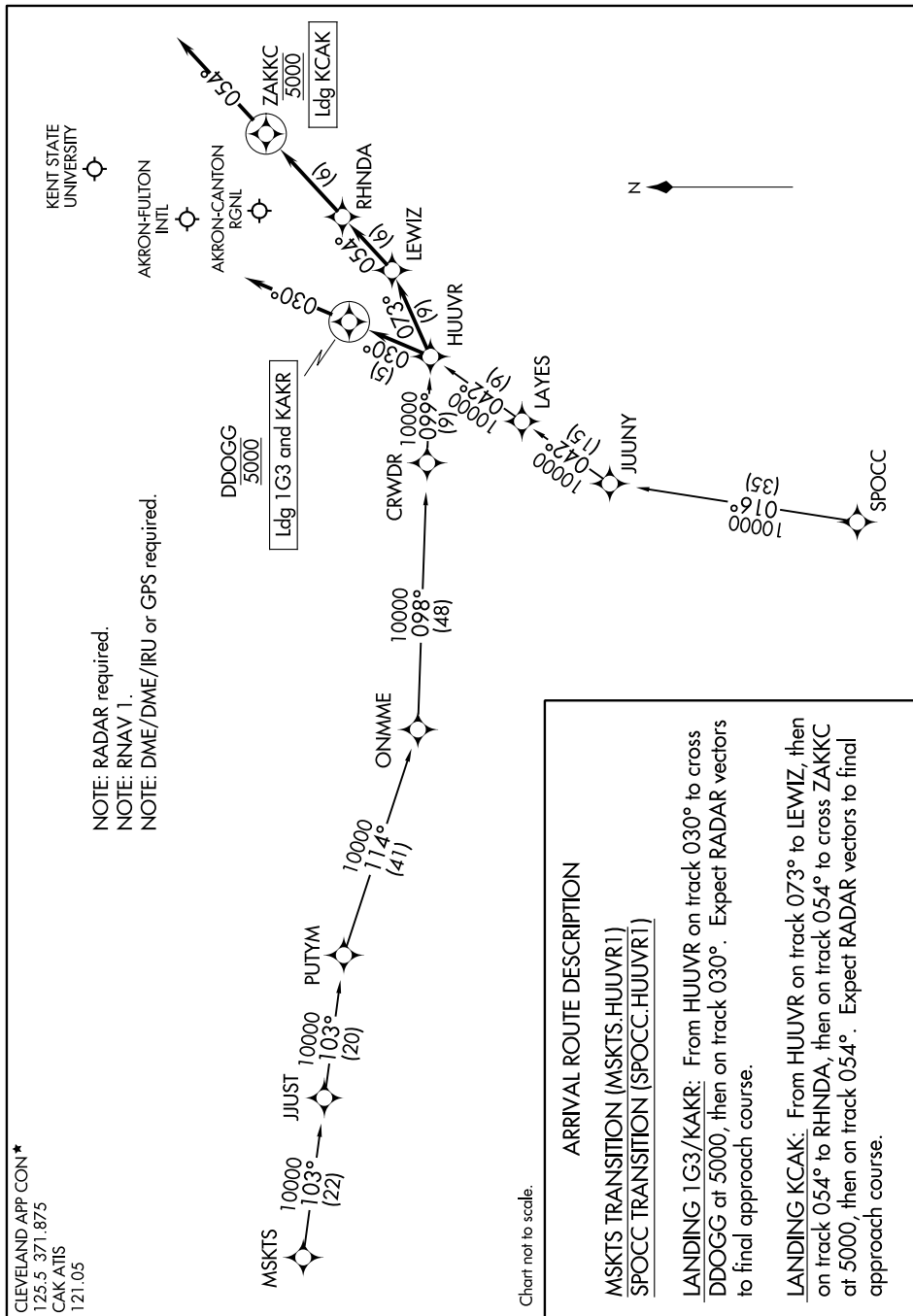

HUUVR ONE ARRIVAL (RNAV)

AKRON, OHIO

(HUUVR.HUUVR1) 24MAY18