



U.S. Department
of Transportation

**Federal Aviation
Administration**

Advisory Circular

Subject: Specification for Airport Light Bases, Transformer Housings, Junction Boxes, and Accessories

Date: 11/06/2015

AC No: AC 150/5345-42H

Initiated by: AAS-100

Change:

1. Purpose.

This advisory circular (AC) contains the specifications for airport light bases, transformer housings, junction boxes, accessories, elevated light fixture covers and stakes. This AC is not intended to be a compilation of currently available product designs. This AC provides the basic standard requirements for critical dimensions and performance requirements to which all manufacturers must demonstrate compliance.

2. Effective date.

Effective six months after the issue date of this AC, only equipment qualified per this specification will be listed in AC 150/5345-53, *Airport Lighting Equipment Certification Program*.

3. Cancellation.

AC 150/5345-42G, *Specification for Airport Light Bases, Transformer Housings, Junction Boxes, and Accessories*, dated September 28, 2012, is canceled.

4. Application.

The Federal Aviation Administration (FAA) recommends the guidance and specifications in this Advisory Circular for airport light bases, transformer housings, junction boxes, accessories, elevated light covers and stakes. In general, use of this AC is not mandatory. However, use of this AC is mandatory for all projects funded with federal grant monies through the Airport Improvement Program (AIP) and with revenue from the Passenger Facility Charges (PFC) Program. See Grant Assistance No. 34, *Policies, Standards, and Specifications*, and PFC Assurance No.9, *Standards and Specifications*. All lighting designs contained in this standard are the only means acceptable to the Administrator to meet the lighting requirements of Title 14 CFR Part 139, *Certification of Airports*, Section 139.311, *Marking, Signs and Lighting*.

5. Principal changes.

- a. Paragraph 1.1 - Type number L-894 for elevated light covers is proposed. Type number L-895 for elevated light mounting stakes is proposed.

- b. Paragraph 3.1 – a note is added to explain light base modifications.
- c. Add paragraph 3.1.3.5.2 to describe elevated light cover plate requirements.
- d. Paragraph 3.2.2 – the last sentence is removed because information about light base modification is already added to paragraph 3.1.
- e. Paragraph 3.2.3.1 - elevated light cover plates and elevated light mounting stakes are removed from AC 150/5345-46, *Specification for Runway and Taxiway Light Fixtures*, and added to this AC to better facilitate common hardware in one AC.
- f. Paragraphs 3.2.3.1.1 through 3.2.3.1.4 are added to describe elevated light cover plate requirements.
- g. Paragraph 3.2.3.2 is added to include elevated light fixture mounting stakes with common hardware.
- h. Paragraphs 3.2.3.2.1 through 3.2.3.2.7 are added to describe elevated light mounting stake requirements.
- i. Paragraph 4.2.8 is added to provide tests and procedures for elevated light cover plates.
- j. Paragraph 4.2.8.1.1 is modified to better facilitate testing with a rubber block of increased thickness.
- k. Paragraph 4.2.9 is added to provide tests and procedures for elevated light mounting stakes.
- l. Figure 3 is modified to show the correct Size E bolt pattern
- m. Figures 6 and 7 “AAA” dimension is changed in both figures for manufacturing uniformity among one piece and sectional light bases.
- n. Figure 7 – AAA dimension tolerance is changed to match the tolerance in Figure 6 for better uniformity.
- o. Figure 9 – mud cover rings have a $\pm 1/16$ inch tolerance added to better facilitate manufacturing.

6. Metric units.

To promote an orderly transition to metric units, this AC includes both English and metric dimensions. The metric conversions may not be exact equivalents, and until there is an official changeover to the metric system, the English dimensions will govern.

7. Feedback on this AC.

If you have suggestions for improving this AC, you may use the [Advisory Circular Feedback](#) form at the end of this AC.

8. **Copies of this AC** are available at:
www.faa.gov/airports/resources/advisory_circulars/

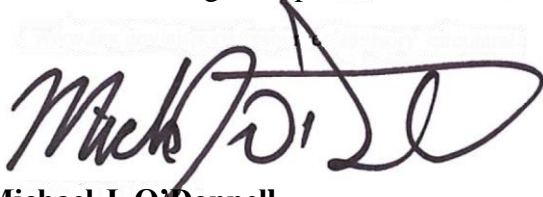
A handwritten signature in black ink, appearing to read "Michael J. O'Donnell". The signature is stylized and written over a faint, light-colored rectangular background.

Michael J. O'Donnell
Director of Airport Safety and Standards

This page intentionally left blank.

Table of Contents

Chapter 1. Scope	1
1.1 Type.....	1
1.2 Class.....	1
1.3 Size.....	2
Chapter 2. Applicable Documents.....	3
2.1 FAA ACs and Engineering Briefs (EB).....	3
2.2 Military Standard and Specification.	3
2.2.1 Military Standard.	3
2.2.2 Military Specification.	3
2.3 American Society for Testing and Materials International (ASTM) Specifications, Test Methods, Standard Practices, and Recommended Practices.	3
2.4 American Society of Mechanical Engineers (ASME).	4
2.5 American Society for Quality (ASQ).	4
2.6 Miscellaneous Documents.	4
Chapter 3. Requirements	5
3.1 General Description and Intended Use.	5
3.1.1 Type L-867 Bases.	5
3.1.2 Type L-868 Bases.	5
3.1.3 General Accessories.....	5
3.2 Fabrication and Materials.	10
3.2.1 Type L-867 Class IA and Class IB Bases and Extensions.	10
3.2.2 Type L-867 Class IIA and Class IIB Bases and Extensions.....	12
3.2.3 Type L-867 Accessories.	13
3.2.4 Type L-868 Class IA and Class IB Bases and Extensions.	16
3.2.5 Type L-868 Accessories.	18
3.2.6 Grounding Lugs.	18
3.2.7 Drains.....	19
3.2.8 Protective Coating.....	19
Chapter 4. Quality Assurance Provisions.....	21
4.1 Type L-867 Class IA and Class IB Certification Testing.	21
4.1.1 Type L-867 Class IA and Class IB Load Test.	21
4.1.2 Type L-867 Class IA and Class IB Weld Integrity Test.....	22
4.1.3 Type L-867 Class IA and Class IB Dimensional Tests.	23
4.1.4 Type L-867 Class IA and Class IB Protective Coating Thickness Test.	23
4.1.5 Type L-867 Class IA and Class IB Visual Inspection.	23
4.1.6 Type L-867 Class IB Potassium Acetate Test.	23
4.2 Type L-867 Class IIA and Class IIB Certification Testing.	24
4.2.1 Type L-867 Class IIA and Class IIB Load Test.	24
4.2.2 Type L-867 Class IIA and Class IIB Weld Integrity Test.	24
4.2.3 Type L-867 Class IIA and Class IIB Temperature Shock Test.	24
4.2.4 Type L-867 Class IIA and Class IIB Dimensional Tests.....	24
4.2.5 Type L-867 Class IIA and Class IIB Protective Coating Thickness Test.....	25

4.2.6 Type L-867 Class IIA and Class IIB Visual Inspection. 25

4.2.7 Type L-867 Class IIB Potassium Acetate Test. 25

4.2.8 Type L-894 Elevated Light Cover Load and Bending Moment Test. 25

4.2.9 Type L-895 Elevated Light Mounting Stake Dimensional Tests. 25

4.3 Type L-868 Class IA and Class IB Certification Testing. 26

4.3.1 Type L-868 Class IA and Class IB Load Test. 26

4.3.2 Type L-868 Class IA and Class IB Fatigue Test. 26

4.3.3 Type L-868 Class IA and Class IB Impact Test. 26

4.3.4 Type L-868 Class IA and Class IB Flange Bolt Torque Test. 26

4.3.5 Type L-868 Class IA and Class IB Weld Integrity Test. 26

4.3.6 Type L-868 Class IA and Class IB Dimensional Tests. 26

4.3.7 Type L-868 Class IA and Class IB Protective Coating Thickness Test. 27

4.3.8 Type L-868 Class IA and Class IB Visual Inspection. 27

4.3.9 Type L-868 Class IB Potassium Acetate Test. 27

4.3.10 Type L-868 Torque Test for Adjustable Height Bases and Extensions. 27

4.4 Production Testing. 28

4.4.1 Lot Size. 28

4.4.2 Sample Size and Acceptance Criteria. 28

4.4.3 Retesting. 28

4.4.4 Type L-867, Class IA and Class IB. 28

4.4.5 Type L-867 Class IIA and Class IIB. 28

4.4.6 Type L-868 Class IA and Class IB. 29

Chapter 5. Preparation For Delivery. 31

5.1 Packing. 31

5.2 Marking. 31

Appendix A. 10-inch (254 mm) Light Base. 41

List of Figures

Figure 1. Flange, Type L-867, Class IA, Class IB, Class IIA, Class IIB 32

Figure 2. Body, Type L-867, Class IA, Class IB, Class IIA, Class IIB 33

Figure 3. Extensions, Type L-867, Class IA, Class IB, Class IIA, Class IIB 34

Figure 4. Accessories, Type L-867 34

Figure 5. Flange, Type L-868, Class IA, Class IB 36

Figure 6. Body, Type L-868, Class IA, Class IB 37

Figure 7. Sectional Body, Type L-868, Class IA, Class IB 38

Figure 8. Extensions, Type L-868 Class IA, Class IB 39

Figure 9. Accessories, Type L-868 40

Figure A-1. Extensions and Spacers for 10-inch (254 mm) Diameter Type L-868 Base, for
Maintenance of Existing Installations Only 42

Chapter 1. SCOPE

This specification sets forth the requirements for light bases, transformer housings, junction boxes, and related accessories.

1.1 Type.

The Federal Aviation Administration (FAA) Type designation of the light bases, extensions, elevated light covers and elevated light stake mountings are as follows:

- | | |
|------------|---|
| Type L-867 | Bases and extensions for applications subject to occasional light vehicular loading but no aircraft or other heavy vehicular loading. |
| Type L-868 | Bases and extensions for applications subject to aircraft and other heavy vehicular loading. |
| Type L-894 | Elevated light cover – not load bearing and mounts on an L-867 light base. |
| Type L-895 | Elevated light stake mounting. |

1.2 Class.

The following class designations apply to Type L-867, L-868, and L-894:

- | | |
|-----------|--|
| Class IA | Bases, extensions and elevated light covers that are fabricated from metal in exact conformance to the critical dimensions and requirements necessary for standardization between parts specified herein. |
| Class IB | Bases, extensions and elevated light covers that are fabricated from metal in exact conformance to the critical dimensions and requirements necessary for standardization between parts specified herein and which have been subjected to corrosion testing and found resistant to deicing fluids containing potassium acetate. |
| Class IIA | Bases, extensions and elevated light covers that are fabricated from non-metallic materials in exact conformance to the critical dimensions and requirements necessary for standardization between parts specified herein. |
| Class IIB | Bases, extensions and elevated light covers that are fabricated from non-metallic materials in exact conformance to the critical dimensions and requirements necessary for standardization between parts specified herein and which have been subjected to corrosion testing and found resistant to deicing fluids containing potassium acetate. |
| Note 1 | Bases, extensions and elevated light covers that meet the Class IB or Class IIB requirements are also considered to meet Class IA or Class IIA requirements, respectively. |

- Note 2 Bases, extensions and elevated light cover plates that are fabricated as either Class IA or Class IB are to perform the same exact function. The only difference between the two classes of bases and extensions is the possible difference in metal or metal surface treatment required to meet the Class IB level of testing.
- Note 3 Bases, extensions and elevated light covers that are fabricated as either Class IIA or Class IIB are to perform the same exact function. The only difference between the two bases and extensions is the possible difference in material or material surface treatment required to meet the Class IIB level of testing.
- Note 4 L-895 elevated light base stakes are Class IA only.

1.3 Size.

Five base size designations are assigned. The size refers to the nominal diameter of the light base and L-894 elevated light cover plates. Sizes and applicable types are as follow:

Note: Example: For a 12 inch L-868 light base, the designation is L-868E.

Size	Type
Size A - 8 inch (203 mm)	Type L-868
Size B - 12 inch (305 mm)	Type L-867, Type L-868, Type L-894
Size C - 15 inch (381 mm)	Type L-868
Size D - 16 inch (406 mm)	Type L-867
Size E - 24 inch (610 mm)	Type L-867

Chapter 2. APPLICABLE DOCUMENTS

The following documents are referenced or complement the information presented in this AC:

2.1 FAA ACs and Engineering Briefs (EB).

The FAA documents listed below contain information pertinent to this specification.

AC 150/5340-30 *Design and Installation Details for Airport Visual Aids.*
Copies of the current edition of the AC may be obtained at no charge from the following FAA website:
www.faa.gov/airports/resources/advisory_circulars/

AC 150/5345-53 *Airport Lighting Equipment Certification Program*

EB 83 *In-pavement Light Fixture Bolts.* Copies of the EB may be obtained at no charge from the following FAA website:
www.faa.gov/airports/engineering/engineering_briefs/

2.2 Military Standard and Specification.

The following Military Standard and Specification (in effect on the date of application for qualification) form a part of this specification and are applicable to the extent specified herein. Copies of military standards and specifications may be obtained at no charge from the following website: quicksearch.dla.mil/

2.2.1 Military Standard.

MIL-STD-810E Environmental Engineering Considerations and Laboratory Tests

2.2.2 Military Specification.

MIL-PRF-26915 Primer Coating, for Steel Surfaces

2.3 American Society for Testing and Materials International (ASTM) Specifications, Test Methods, Standard Practices, and Recommended Practices.

The following specifications, test methods, standard practices, and recommended practices (in effect on the date of application for qualification to AC150/5345-53) form a part of this specification and are applicable to the extent specified herein. Copies of ASTM specifications, test methods, and recommended practices may be obtained from the American Society for Testing and Materials International, or from the website: www.astm.org/

A36 Standard Specification for Carbon Structural Steel

A123/A123M Standard Specification for Zinc (Hot-Dip Galvanized) Coatings on Iron and Steel Products

A 153	Standard Specification for Zinc Coating (Hot-Dip) on Iron and Steel Hardware
A385/A385M	Standard Practice for Providing High-Quality Zinc Coatings (Hot-Dip)
B 633	Standard Specification for Electrodeposited Coatings of Zinc on Iron and Steel
C109/C109M	Standard Test Method for Compressive Strength of Hydraulic Cement Mortars (Using 2-in. or [50-mm] Cube Specimens
C617	Standard Practice for Capping Cylindrical Concrete Specimens
C827/C827M	Standard Test Method for Change in Height at Early Ages of Cylindrical Specimens of Cementitious Mixtures
D 2240	Standard Test Method for Rubber Property-Durometer Hardness
E 23	Standard Test Methods for Notched Bar Impact Testing of Metallic Materials

2.4 **American Society of Mechanical Engineers (ASME).**

The following standard (in effect on the date of application for qualification) forms a part of this specification and is applicable to the extent specified herein. Copies of ASME standards may be obtained from the American Society of Mechanical Engineers, or from the website: www.asme.org/

B46.1 Surface Texture, Surface Roughness, Waviness and Lay

2.5 **American Society for Quality (ASQ).**

The following standard (in effect on the date of application for qualification) forms a part of this specification and is applicable to the extent specified herein. Copies of ASQ standards may be obtained from the American Society for Quality Control, or from the website: www.asq.org/

ANSI/ASQ Z1.4 and Z1.9 Sampling Procedures and Tables

2.6 **Miscellaneous Documents.**

The Design, Installation and Maintenance of In-Pavement Airport Lighting, by Arthur S. Schai, F.I.E.S. Library of Congress Catalog Card Number 86-81865. This document does not form a part of this specification but is listed as valuable resource material on the design and installation of light bases. (Reference AC 150/5340-30 for installation details and options.) Download at: www.faa.gov/airports/resources/advisory_circulars/index.cfm/go/document.list.

Chapter 3. REQUIREMENTS

3.1 General Description and Intended Use.

Note: The modification of standard certified components renders them non-standard and voids their certification. The only exception to this is the cutting of additional conduit holes during installation and the installation of threaded inserts in the light base upper flange because they do not adversely affect the structural integrity. See paragraph 3.2.8 for corrosion control considerations when modifying any galvanized light base.

3.1.1 Type L-867 Bases.

Type L-867 is used as a mounting base for airport light fixtures, as a transformer housing and as an electrical junction box. The Type L-867 base must be designed to withstand occasional light vehicular loads. It is subject to direct earth burial with and without concrete backfill.

3.1.2 Type L-868 Bases.

Type L-868 is used as a mounting base for in-pavement airport light fixtures, as a housing for series circuit transformers, and as an electrical junction box. It must be designed to withstand aircraft and other heavy vehicular loadings. The design must allow the installation of any in-pavement fixture.

The Type L-868 top flange and base must be designed to meet the dimensional requirements and performance requirements, as detailed in this document, to assure proper mating between the base and an in-pavement light fixture.

3.1.3 General Accessories.

Accessories are used to make corrections and adjustments to Type L-867 and Type L-868 bases, and to facilitate proper performance of the lighting fixture that the base supports. Examples of accessories are listed below, and when used in conjunction with a base specified in this AC, must not reduce the performance capabilities of that base.

3.1.3.1 Spacer Rings.

Spacer rings are available in various designs depending on the application and are available in various thicknesses and diameters and are generally installed between the base flange and the light fixture or other accessory.

- See Figures 3 and 8 for minimum and maximum height.
- To preserve the base integrity and proper bolt torque, **a maximum of three spacer rings may be stacked together.**
- Each type of L-868 spacer ring, when interfaced to the fixture housing, may be provided with a protective dam that encircles the spacer ring.
- The protective dam is 1/8 inch shorter than the light fixture housing it protects and has an inner diameter (ID) that is a maximum 1/4 inch greater

than the outer diameter (OD) of the fixture housing. The OD of the protective dam must not exceed the OD of the light base top flange ring.

- The various types of spacer rings are noted in paragraphs 3.1.3.1.1 through 3.1.3.1.4.

Note 1: The protective dam prevents grout, sealant, or other pavement material from sealing the light fixture in place.

Note 2: On field adjustable bases and extensions, the protective dam may be integral to the base or extension top flange ring as long as the requirements noted above and the base or extension top flange ring dimensions comply with the dimensional requirements of this AC.

3.1.3.1.1 Flat Spacer Ring.

A flat spacer ring is used to provide height adjustment for Type L-867 or Type L-868 bases.

3.1.3.1.2 Grooved Spacer Ring.

A grooved spacer ring, when used with a provided “O” ring gasket, is used to provide a seal between the in-pavement fixture and spacer ring for the purpose of minimizing the entrance of surface water and other liquids into the Type L-868 base.

3.1.3.1.3 Tapered Spacer Ring.

Tapered spacer rings are used to provide level and/or height correction for out-of-level Type L-868 and L-867 bases.

3.1.3.1.4 Azimuth Correction Spacer Ring.

Azimuth correction spacer rings are used to correct the alignment of light fixtures attached to misaligned Type L-868 bases.

3.1.3.2 Conduit Connections.

Conduit connections permit connection of underground conduit to the bases. Conduit connections (number, type, size, and location) are to be provided as specified and must meet the environmental requirements of the Class base with which they are utilized. Conduit connections may include hubs, grommets, or other devices suited for the application.

3.1.3.3 Adapter Rings.

Adapter rings are used for converting the bolt circle of an existing base to that of a fixture having a different bolt circle or to that of a threaded adaptor ring for adjustable threaded extensions. No modification of the existing base should be required. All fixture mounting bolts must have at least 1/2 inch (13 mm) of thread engagement into the ring.

3.1.3.4 Base Extensions, Fixed and Adjustable.

Base extensions are used to provide height adjustments to both Type L-867 and Type L-868 bases. They are used with bases when the required new elevation exceeds the capability of spacer rings to obtain it.

- Base extension capability can be provided by installing either a fixed extension or a field adjustable extension that interfaces to the top flange of an existing type light base and has the same dimensional top flange and fixture clearance as the existing base.
- Care should be taken to ensure that the proper Class of extension is utilized. Extensions are equal to or greater than 1-3/4 inches (44 mm) for Type L-867 and 2-1/4 inches (63.5 mm) for Type L-868.
- Extensions and spacers will be dimensioned per Figures 3 and 8. Note that fixed extensions are shown for dimensional purposes only.
- Various methods of providing adjustable heights are possible (including proprietary stainless steel adjustable threaded extensions), but all must meet the applicable dimensions in Figures 3 and 8.

Type L-867 bases with provisions for height adjustment may be specified to meet local conditions. The base extensions, which rely on the top flange and the embedment material to support the load, are not suitable for direct earth burial. If the adjustable height base is intended to support the load without top flange and embedment assistance, it is suitable for direct earth burial and must be capable of withstanding the full load test requirement at its maximum extension.

All L-868 bases that utilize a method of height adjustment that is integral to the base or extension and is intended for field adjustment must, during qualification testing, be subjected to a torque test to ensure there will be no top flange rotation under normal operating conditions. Reference paragraph 4.3.10.

3.1.3.5 Covers.

Various covers are available to facilitate the proper installation of bases. All covers must utilize manufacturer furnished fully threaded (tap bolts) 18-8 stainless steel, hex head 3/8" bolts (or coated bolts per Engineering Brief 83) sufficiently long to provide full thread engagement into the mounting surface.

3.1.3.5.1 Blank Covers.

Blank covers are used to provide a cover for bases when no light fixture is to be installed.

- Blank covers must be metallic and meet the applicable dimensional requirements of the type base to which they are attached. For Type L-868

load bearing bases, the cover must be equal in thickness to the light fixture.

- For Type L-867B and Type L-867D non-load bearing bases, the cover must be a minimum of 3/8 inches (10 mm). For Type L-867E bases, the cover must be a minimum of 1/2 inch (13 mm).
- Covers weighing more than 30 pounds (13.6 kilograms) must have (2) opposite holes of the (6) 7/16 inch (11 mm) through holes tapped 1/2"-13 as a means to affix a lifting eye bolt for ease of removal.
- All cover plates 1/2 inch (13 mm) or thicker must have all bolt holes counter-bored 1-1/8 inches × 3/8 inches (29 mm × 10 mm) deep.

3.1.3.5.2 Elevated Light Covers.

Elevated light covers are used to mount elevated lights on an L-867 light base.

- Elevated light covers must be fabricated of metal and meet the dimensional requirements so that they may be attached to an L-867 light base.
- Elevated light covers must meet the load and bending requirements in 3.2.3.1.4.

3.1.3.5.3 Mud Covers.

Mud covers may stand alone or may be used in conjunction with plywood covers on Type L-867 and Type L-868 bases to protect the base flange during construction, and to include surface marking to facilitate locating the center of the base when coring out to locate the base after pavement overlay. Mud covers are appropriately sized for the specific bases they are to protect.

3.1.3.5.4 Shipping Covers.

Plywood covers are used to protect bases during shipping and installation and are to be installed on all base or base extension shipments.

- For all galvanized bases, a 3 mil (0.003 inch) polyethylene shipping gasket may be installed between the base and plywood cover or, as an alternative, the plywood cover should be waxed on the bottom surface to eliminate the bonding action of the plywood and zinc.
- The Type L-868 plywood cover should also be waxed on the OD edge to facilitate easy removal from any surrounding embedment material.
- Plywood should be exterior grade 1/2 inch (13 mm) thick Bb/Cc or other material of equal strength and weather resistance (reference Figure 9) for Type L-867 light bases.

- For Type L-868B light bases, the plywood must be equal to the thickness of the light fixture 3/4 inch (19 mm) or 1-1/4 inch (31.75 mm) for L-868C.
- When shipped with a mud cover on top, the total thickness of mud cover and plywood cover must equal the thickness of the light fixture.

Note: The thickness of the light fixture is the height of fixture flange at the OD of the fixture.

3.1.3.6 Grounding Connections.

To provide maintenance personnel electrical safety, The manufacturer must install both an internal and external ground strap. The ground strap functions as a means to connect a ground lug that is connected to an earth ground or a safety ground conductor.

- For Class I bases, a metallic ground connector or strap must be welded to the interior and exterior wall of each base before applying surface protection. The details and location of the ground straps are shown in Figures 2 and 6.
- The location of the connector may be varied to meet specific conditions. A bronze or copper ground connector should not be fastened to the ground connector or strap until after the base surface protection is applied.

For Class II bases, the ground connector or strap must provide a positive ground connection path to a light fixture.

Note: Under no circumstances should an exothermic weld be used to attach a ground or counterpoise connection to a galvanized light base because of the potential for heat damage to the galvanized coating. Under field conditions, repairs to the zinc coating after an exothermic weld are usually ineffective. If the galvanized coating is compromised, the corrosion of exposed light base steel will accelerate.

3.1.3.6.1 Grounding Connections using Exothermic Welds.

For light bases that will use exothermically welded ground connections, the manufacturer may offer a light base with a 304 stainless steel ground rod that is 0.75 inch (19 millimeters (mm)) outside diameter by 3.00 inches (76.2 mm) long. The rod must be welded to the light base before applying any form of surface protection. The rod must be welded to the exterior of the light base at the same locations as a ground strap per Figures 2 and 6.

3.1.3.7 Drains.

The conduit/base system should have drains installed in the bases at low points in the system to provide for drainage of water and deicing fluids away from the base and conduit system. If water and deicing fluids are allowed to

pool for long periods of time in the light base, they will hasten corrosion of both the conduit and base system.

3.2 Fabrication and Materials.

Bases and related accessories, designed to function as light bases, transformer housings, and junction boxes, must be fabricated of suitable material to meet the following standards. Appropriate separation material must be used between dissimilar metals to prevent galvanic action between flange rings, spacer rings etc. Copper ground components and stainless steel bolts are exempted. This separation material must not deform at 450 psi (a load equivalent to the L-868 load test) to prevent compression and subsequent loosening of bolts.

3.2.1 Type L-867 Class IA and Class IB Bases and Extensions.

- Type L-867 Class IA bases, extensions, and Type L-894 elevated light covers must be fabricated from an appropriate metal using fabrication techniques that will produce units meeting the testing requirements in paragraph 4.1.
- Class IB bases must be fabricated from metal using fabrication techniques that will produce units meeting the appropriate testing requirements of paragraph 4.1.
- All bases and extensions (excluding spacers and covers) must be labeled using a suitable long lasting contrasting color ink stamp with either the letter A or B to indicate the Class suffix under which the certification has been obtained.
- The stamp must be a minimum of one inch (25 mm) in height and placed on the exterior and interior walls of the light base, no more than 6 inches (152 mm) below the base flange. All components described in this paragraph must be manufactured such that their use does not require existing bases, extensions or any existing components installed in the ground to be cut or modified in any manner.

3.2.1.1 Flange.

The dimensions of the flange must be as shown in Figure 1. The flat surface of the flange must be installed at an angle of 90 ± 0.25 degrees to the axis of the cylindrical body. The flange must be continuously attached to the body to provide a watertight seal.

3.2.1.2 Body.

The body, including the sides and bottom, must be fabricated from one or more pieces. The dimensions of the body must be as shown in Figure 2.

- Two conduit entrances must be provided and installed near the bottom of the base. The location and size, per Figure 2, is considered standard. However, the location, number, type, and size can be altered to meet project requirements.

- Any sharp edges formed on the inside of the body must be removed to prevent cutting or chafing the cable insulation.
- The length of the body section as shown in Figure 2 is considered standard, but the length may be varied to meet special conditions.

3.2.1.3 Extensions.

The dimensions of the extensions and spacer rings must be per Figure 3. Extensions for Type L-867 bases must be ordered to length with a minimum length of 1-3/4 inches (44.5 mm) and a tolerance of $\pm 1/16$ inch (1.5 mm). Flat spacer rings are utilized for height adjustments from 1/16 inch (1.5 mm) through 1-11/16 inches (42.86 mm) in 1/16 inch (1.5 mm) increments.

3.2.1.4 Adjustable Height Type L-867 Class IA and Class IB Bases and Extensions.

Adjustable height Type L-867, Class IA and IB bases and extensions must have a provision for adjusting the height of the top flange.

- Various methods of providing height adjustment are possible (including proprietary stainless steel adjustable threaded extensions). The top flange must have the identical dimensions as the top flange of the standard base.
- For adjustable bases, the body must also have the identical dimensions as the standard base. For adjustable extensions, the top flange and body of the extension must also be compatible with light fixtures and with existing parts in the ground without field modifications to certified parts. The adjustable top flange and supporting wall may mate into the base body either externally or internally of the base supporting wall.
- If the adjustable base is designed for installation in earth (no embedment support required), the base must be load tested fully extended in free space.
- If the base requires portland cement concrete (PCC) embedment to meet the load requirements, it may be tested as directed by the testing laboratory with supporting PCC embedment to simulate an actual installation. The manufacturer must indicate by the suffix "PCC" to the catalog number that the base does not meet the load requirements of Type L-867, unless the top base flange is embedded and supported by PCC.
- The light bases must be dimensioned per Figure 2 with regard to light fixture interface and critical dimensions.

3.2.1.5 Bolts.

Bolts suitable for use in threaded holes, as shown in Figures 1 and 2, must be supplied with each base and extension assembly. The bolts must conform to the dimensions specified in the notes in Figures 1, 2, and 3 and must be fully

threaded and fabricated from 18-8 stainless steel. Coated steel fasteners per EB 83 may also be used.

3.2.2 Type L-867 Class IIA and Class IIB Bases and Extensions.

Type L-867 bases and extensions, Class IIA and IIB, must be fabricated from suitable materials and dimensioned to produce units meeting the appropriate testing requirements per paragraph 4.2.

- All bases and extensions (excluding spacers and covers) must be labeled using a suitable long lasting contrasting color ink stamp with either the letter A or B to indicate the Class suffix under which the certification has been obtained.
- The stamp must be a minimum of one inch (25.4 mm) in height and placed on the exterior and interior walls of the light base, no more than 6 inches (152 mm) below the base flange.
- All components described in this paragraph must be manufactured such that their use does not require existing light bases, extensions, or any existing components installed in the ground to be cut or modified in any manner.

3.2.2.1 Flange.

The flange must be fabricated from suitable materials and must meet the same critical lighting fixture interface dimensions specified for Class I in Figure 1. Flange thickness and material should be sufficient to pass the load test specified in paragraph 4.1.1. The flange must be continuously attached to the body to provide a watertight seal.

3.2.2.2 Body.

The body, sides, and bottom may be fabricated from one or more pieces. The sides and bottom must be fabricated from suitable materials sufficient to pass the load test described in paragraph 4.2.1. Two conduit entrances must be installed near the bottom of the base. The location and size, as shown in Figure 2, must be considered standard. However, the location, number, type, and size may be altered to meet project requirements. Any sharp edges formed on the inside of the body must be removed to prevent cutting or chafing of the cable insulation. The length of the body section as shown in Figure 2 must be considered standard, but the length may be varied to meet special conditions.

3.2.2.3 Extensions.

The dimensions of the extensions and spacer rings must be per Figure 3. Extensions must be fabricated of the same materials and dimensions specified in paragraphs 3.2.2.1 and 3.2.2.2. Extensions must be ordered to length with a minimum length of 1-3/4 inches (44.5 mm) and a tolerance of $\pm 1/16$ inch (1.5 mm). Flat spacer rings are utilized for height adjustments from 1/16 inch (1.5 mm) through 1-11/16 inches (42.86 mm) in 1/16 inch (1.5 mm) increments.

3.2.2.4 Adjustable Height Type L-867 Class IIA and Class IIB Bases and Extensions.

- Adjustable height Type L-867 bases and extensions must have a provision for adjusting the height of the top flange. Various methods of providing height adjustment are possible (including proprietary stainless steel adjustable threaded extensions).
- The top flange must have the identical dimensions as the top flange of the standard base.
- For adjustable bases, the body must also have the identical dimensions as the standard base.
- For adjustable extensions, the top flange and body of the extension must also be compatible with lighting fixtures and with existing parts in the ground without field modifications to certified parts.
- The adjustable top flange and supporting wall may mate into the base body either externally or internally of the base supporting wall.
- If the adjustable base is designed for installation in earth (no embedment support required) the base must be load tested fully extended in free space.
- If the base requires PCC embedment in order to meet the loading requirements, it may be tested with supporting PCC embedment to simulate actual installation as directed by the testing laboratory.
- The manufacturer must indicate by the suffix “PCC” to the catalog number that the base does not meet the load requirements of Type L-867 unless the top base flange is embedded and supported by PCC.
- The light bases must be dimensioned per Figure 2 with regard to fixture light interface and critical dimensions.

3.2.2.5 Bolts.

Bolts suitable for use in threaded holes as shown in Figures 1, 2, and 3 must be supplied with each base and extension assembly. The bolts must be per the dimensions specified in the notes in Figures 1, 2, and 3, and must be fully threaded (tap bolt) and fabricated from 18-8 stainless steel. Coated steel fasteners per EB 83 may also be used.

3.2.3 Type L-867 Accessories.

Various accessories are necessary to facilitate construction involving Type L-867 bases or to make corrections or adjustments to Type L-867 bases. These accessories are detailed in Figure 4.

3.2.3.1 Type L-894 Elevated Light Covers.

An elevated light cover is used to mount the elevated light fixture to a Type L-867 light base.

- The L-894 elevated light cover must have a diameter and bolt-hole circle that corresponds to one of the L-867 light base sizes listed in this AC.
- The elevated light cover must be designed to receive the frangible device provided; typically, this is a straight female thread.
- The elevated light cover must not be higher than 0.63 inches (16 mm), measured from the top of the light base plate bolt circle.

3.2.3.1.1 L-894 Elevated Light Cover Thread Sizes.

Thread sizes for elevated light covers are specified by the light fixture manufacturer. For example, typical thread sizes are: 1-1/2 in. X 12 Unified National Fine (UNF) and 2-in. National Pipe Straight (NPS). The depth of threads must be no more than 0.88 in. (22.35 mm).

3.2.3.1.2 Type L-894 Elevated Light Cover Gasket.

A neoprene gasket (or equivalent) must be provided with the cover plate to form a watertight seal between the cover plate and the L-867 light base. The gasket must have a nominal thickness of 1/8 inch (3 mm) and fit the bolt circle of the L-867 light base flange.

3.2.3.1.3 L-894 Receptacle Leads.

The mounting system for an elevated light cover must firmly position the isolating transformer receptacle (typically an L-823, Class A, Type II, Class 8 receptacle – see AC 150/5345-26, *FAA Specification for L-823 Plug and Receptacle Cable Connectors*) so its mating face is at the yield point and so it will not be dislodged by separation from the plug. Drainage must be provided below the yield point so that no water builds up above the mating surface of the connector.

3.2.3.1.4 L-894 Elevated Light Cover Load and Bending Moments.

When the elevated light cover is bolted to an L-867 light base, it must withstand an evenly distributed static compressive load of 2,500 pounds (1134 kg) and a bending moment of 2,500 foot-pounds (3,390 N·m) for the L-804 and 700 foot-pounds (949 N·m) for all other applications without damage or permanent deformation.

3.2.3.1.5 L-894 Elevated Light Cover Ground Connections.

Elevated light covers must furnish a ground lug or bolt to facilitate a ground connection. The ground connection must accommodate a minimum of a #6 AWG stranded wire or ground braid. See AC 150/5340-30, *Design and Installation Details for Airport Visual Aids*, current revision, for additional information about grounds and ground connections.

3.2.3.1.6 L-894 elevated Light Cover Color and Finish.

For non-optical surfaces, the exterior must be painted with one prime, one body, and one finish coat of paint. The prime coat must be appropriate for the particular metal being painted. The finish coat must match color FED-STD-595, Appendix 4, Color Number 13538, DOT Highway Yellow, ANA506 unless otherwise specified. Powder coatings may be used provided that the performance of the coating is equivalent to or better than a painted coating.

3.2.3.2 L-895 Elevated Light Stake Mounting.

When not installed on a light base, the elevated light fixture must be mated with a stake made of 2 x 2 x 3/16 inch (51 x 51 x 5 mm) L-type steel angle stock. See AC 150/5340-30 (current revision), Figure 23, for a drawing of an elevated light stake mounting.

3.2.3.2.1 L-895 Elevated Light Stake Fitting.

The stake must have a fitting attached at the top to receive the frangible coupling.

3.2.3.2.2 L-895 Elevated Light Stake Receptacle Leads.

The mounting system for an elevated light mounting stake must position the isolating transformer receptacle (typically an L-823, Class A, Type II, Class 8 receptacle – see AC 150/5345-26) so its mating face is at the yield point and so it will not be dislodged by separation from the plug. Drainage must be provided around the receptacle retainer to prevent water buildup around the yield point.

3.2.3.2.3 L-895 Elevated Light Stake Standard Length.

The standard length of the stake and fitting is 30 inches (76 cm). Longer stakes may be fabricated upon approval if there are special conditions for soil or frost line.

3.2.3.2.4 L-895 Elevated Light Mounting Stake Ground Clamps.

A grounding clamp must be supplied by the manufacturer if specified by the customer. The grounding clamp must accommodate a minimum of a #6 AWG copper conductor.

3.2.3.2.5 L-895 Elevated Light Mounting Stake Protective Coatings.

All protective coatings must be per paragraph 3.2.8.

3.2.3.2.6 L-895 Alternate Mounting Stakes.

Alternate staking methods may be used if it can be demonstrated that equal support and durability are provided.

3.2.3.2.7 L-804 Light Fixtures.

L-804 light fixtures must not be stake mounted.

3.2.4 Type L-868 Class IA and Class IB Bases and Extensions.

Type L-868, Class IA bases and extensions, must be fabricated from an appropriate metal (see note below) and constructed in such a manner to meet the appropriate testing requirements per paragraph 4.3. Class IB bases and extensions must be fabricated from an appropriate metal (see note below) and constructed in such a manner as to meet the appropriate testing requirements specified in paragraph 4.3.

Note: If a material other than ASTM A36 steel is used for a major load bearing structural component, the material must meet the mechanical property yield and tensile values of A36 steel. A material with yield and tensile stress values lower than the minimum specified values of A36 steel may be used if the manufacturer can demonstrate conformance to the requirements set forth in chapter 4 of this specification.

All bases and extensions (excluding spacers and covers) must be labeled using a suitable long lasting contrasting color ink stamp with either the letter A or B to indicate the Class suffix under which the certification has been obtained. The stamp must be a minimum 1 inch (25 mm) in height and placed on the exterior and interior wall of the base, no more than 6 inches (152 mm) below the base flange.

All components described in this paragraph must be manufactured such that their use does not require existing bases, extensions or any existing components installed in the ground to be cut or modified in any manner. The modification of standard, certified components renders them non-standard and voids their certification. The only exception to this is the cutting of additional conduit holes during installation and the installation of threaded inserts in the flange as these do not affect the structural integrity of a standard unit.

3.2.4.1 Flange.

The dimensions of the flange must be as shown in Figure 5.

- The flat surface of the flange must be installed at an angle of 90 degrees, ± 0.125 degree, to the axis of the cylindrical body of the base. The flange must be continuously attached to the body to provide a watertight seal.
- The flange faces, outside and inside diameter, must be finished per ASME B 46.1.
- The bolt hole size and placement must be as shown in Figure 5.
- The bolt hole may be integral to the flange or contained in metal insert located in the flange.
- A bolt installed in the flange bolt hole must be capable of accepting a bolt torque test per paragraph 4.3.4. As part of the base testing, any insert or remedial device used for correcting threads damaged while in service must be tested in the base flange as part of the base in which it is intended for service.

3.2.4.2 Body.

The body section, sides and bottom, may be formed from one or more pieces.

- One piece body sections must have an anchor ring (mid-ring) attached to the body by a continuous weld applied to the upper side and lower side of the ring per Figure 6.
- The length of the one piece body section shown in Figure 6 must be considered a standard, but the overall length may vary to meet specific conditions.
- Two 2-inch (51 mm) conduit entrances must be provided near the bottom of the body. The location, number, and size of conduit entrances shown in Figure 6 must be considered standard, but the size, location, and number of connections may be varied to meet specific conditions. Any sharp edges at the conduit entrances must be removed to prevent cutting or chafing of the cable insulation.
- When sectional bases are specified, the sections must be dimensioned per Figure 7.

3.2.4.3 Extensions.

- Extensions must be fabricated from the appropriate metal for either Class IA or Class IB bases.
- The dimensions of extensions must be per Figure 8.
- The minimum extension length must be 2-1/4 inches (51 mm).
- Flat spacer rings must be used for height corrections of 1/16 inch (1.6 mm) to 2-3/16 inches (62 mm) in 1/16 inch (1.6 mm) increments. Flat spacer ring dimensions are shown in Figure 8.
- If specified, grooved spacer rings may be used for height corrections of 1/4 inch (3.2 mm) to 2-7/16 inches (62 mm) in 1/16 inch (1.6 mm) increments.
- **To avoid problems with bolt tension, only a maximum of three spacer rings may be stacked together.**

3.2.4.4 Adjustable Height Type L-868, Class IA and Class IB Bases and Extensions.

Adjustable height Type L-868, Class IA and IB bases and extensions must have a provision for adjusting the height of the top flange.

- Various methods of providing height adjustment are possible (including proprietary stainless steel adjustable threaded extensions).

- The top flange must have the identical dimensions as the top flange of the standard base.
- For adjustable bases, the body must also have the identical dimensions as the standard base.
- For adjustable extensions, the top flange and body of the extension must also be compatible with light fixtures and with existing parts in the ground without field modifications to certified parts.
- The adjustable top flange and supporting wall may mate into the base body either externally or internally of the base supporting wall.

3.2.4.5 Bolts.

Bolts suitable for use in the threaded holes per Figures 5, 6, and 7 must be supplied with each spacer ring.

- The bolts must be of sufficient length to provide a full thread connection with the light base flange when the spacer ring is inserted between the light fixture and the light base flange.
- If bases or extensions are ordered without spacer rings, bolts conforming to the dimensions specified in the notes in Figures 5, 6, and 7 must be supplied.
- All bolts must be fully threaded (also known as a tap bolt), fabricated from 18-8 stainless steel and supplied with two part stainless steel locking washers.
- Anti-seize material is recommended to be furnished and utilized by the installing contractor when installing stainless steel bolts (Reference AC 150/5340-30).
- Anti-seize material is not supplied by the light base manufacturer. No antiseize material is required for coated fasteners per EB 83.
- Coated steel fasteners per EB 83 may also be used. All finished bolt sizes must be the same as stainless steel bolts.

3.2.5 Type L-868 Accessories.

Various accessories are necessary to facilitate construction involving Type L-868 bases or make corrections or adjustments to Type L-868 bases. These accessories are detailed in Figure 9.

3.2.6 Grounding Lugs.

Ground connectors or straps must be supplied with each base.

- A metallic ground connector or strap must be welded to the interior and exterior wall of each base before applying surface protection.
- The details and location of the ground connectors are shown in Figure 6.
- The location of the connector may be varied to meet specific conditions. A bronze or copper ground connector should not be fastened to the ground connector or strap until after the base surface protection is applied.

Note: Under no circumstances should an exothermic weld be used to attach a ground or counterpoise connection to a galvanized light base because of potential heat damage to the galvanized coating. Under field conditions, repairs to the zinc coating after an exothermic weld are ineffective. If the galvanized coating is compromised, the corrosion of exposed light base steel will accelerate.

3.2.7 Drains.

If specified, a drain should be provided in the bottom of the base prior to applying surface protection. When not otherwise specified, the drain should be 3/4 inch (19 mm) in diameter.

3.2.8 Protective Coating.

After fabrication all burrs and sharp edges must be removed.

- All ferrous metal parts must be treated for corrosion protection.
- Prior to tapping operations, all parts of Class I bases, extensions, and spacer rings in excess of 1/4 inch (6.35 mm) in thickness must be hot-dip galvanized per ASTM A123/A123M applied per ASTM A385.
- All parts of L-895 elevated light base stakes must be hot dip galvanized per ASTM A123/A123M that is applied per ASTM A385. Other coatings may be used if the same level of corrosion protection is demonstrated.
- Flanges, covers, and rings must be wiped smooth to a flatness of ± 0.010 inch (0.254 mm).
- Plates and rings 1/4 inch (6.35 mm) or less in thickness, grooved extensions, and grooved spacer rings when made of ferrous metal must be plated with zinc per the requirements of ASTM B633, Type II, Class I or hot dip galvanized per ASTM A123/A123M.
- Tapped holes for conduit must be protected with a polyurethane varnish or equivalent.
- A zinc dust primer meeting per MIL-PRF-26915 is permitted for touchup.

- The area covered by zinc dust primer must not exceed 10 percent of the total treated area.
- Any cast iron may be coated with a minimum of 2.0 mils of oxyplast powder in lieu of galvanizing.
- Class IA base extensions and spacer rings must utilize surface protection that meets testing requirements per paragraph 4.4.

Note: If a protective plastic coating is used over a galvanized coating or metal plating, do not cover the light base threaded holes with the coating.

Chapter 4. QUALITY ASSURANCE PROVISIONS

Equipment produced under this specification may be eligible for funding for installation at airports under Federal grant assistance programs for airports.

- To be eligible for installation under Federal grant assistance programs, manufacturers of the types of equipment specified herein are required to certify or furnish proof to the airport sponsor, or the sponsor's representative, that the equipment is certified by an FAA-approved Third Party Certification Body to meet the following test specimen, and production provisions established in paragraphs 4.1, 4.2 and 4.3 Certification Testing.
- Certification testing is intended to ensure that the materials and fabrication methods are adequate to provide acceptable in-service performance of light bases, transformer housings, junction boxes, accessories, elevated light covers and stakes for elevated light mounting.
- Certification testing is required for each type, class, and size of light base, transformer housing, junction box, accessory, elevated light covers and stakes for elevated light mounting produced.
- The third party certification body must make a record (for up to seven years beyond the life of the certification) of the exact material and fabrication process used for the prototype submitted for certification.
- Any change in the product material or fabrication process requires the certification of the resultant product as a new product initially submitted for certification.
- After testing and qualification are complete, the prototype accepted for qualification must function as the dimensional and workmanship model for all subsequent production units.

4.1 Type L-867 Class IA and Class IB Certification Testing.

Type L-867, Class IA and Class IB bases and extensions fabricated in accordance with the materials and dimensions specified herein must be capable of passing the following tests:

4.1.1 Type L-867 Class IA and Class IB Load Test.

Sample bases and extensions must be subject to the load test described below.

- The base and cover assembly or assemblies including spacer rings, extensions, and multi-section bodies must be bolted together and placed on a flat steel plate mounted in a standard testing machine. The light base manufacturer will specify the correct torque and bolts to be employed for proper assembly.
- The test section must be a unit in height deemed to be the maximum height to be furnished by the manufacturer with four 2 inch (51 mm) conduit entrances located

in the body section, located at 90 degree increments, 2-1/2 inches (64 mm) from the bottom of the base.

- A load must be applied to the top part of the base through a block of rubber 1.50 inches (38 mm) (± 0.25 inches (6.35 mm)) thick, with a diameter equal to the cover plate, and having a durometer hardness of 55 to 70. A load of 250 psi (1724 kPa) must be applied uniformly over the area of the rubber block at a rate not to exceed 10,000 pounds (4536 kg) per minute.
- The light base or any of its components will be considered unsatisfactory if there is any permanent deformation or cracking of material or coating.
- The test will be repeated three times.
- After each loading, the bolts must be checked for loss of tension.
- The bolts must be torqued to the manufacturer's recommended service torque after the first two loadings.
- The base and/or assembly will be considered unsatisfactory if there is any loss of torque in the bolts or permanent deformation of the flange or coating after the third loading.
- Load testing is to be performed on free standing units.

4.1.1.1 Type L-867 Class IA and Class IB Load Test, Adjustable Height Bases and Extensions.

If the adjustable base or extension is designed for installation in earth (no embedment support required), the base or extension must be tested fully extended in free space and must be subject to the load test in paragraph 4.1.1. If the base or extension requires PCC embedment to meet the loading requirements, it must be tested to the requirements in paragraph 4.1.1 with supporting PCC embedment to simulate actual installation as directed by the testing laboratory.

4.1.2 Type L-867 Class IA and Class IB Weld Integrity Test.

This test must be performed after each assembly has undergone the load test described in paragraph 4.1.1.

- An internal air or hydraulic pressure of 12 psi, ± 2 psi, (83 kPa, ± 14 kPa) must be maintained within the assembly using pressure fittings.
- The conduit entrances must include a sample of the conduit interfaces (hub, grommet etc.) that are offered by the manufacturer for interfacing to the conduit. The conduit entrances must include conduit stubs suitably plugged during the conducting of the test.

- A high foam soap or detergent solution of low surface tension must be brushed on welds, seams, and joints to detect leakage. Alternatively, the assembly may be submerged in a tank of water while pressurized to detect any air leakage.
- The assembly will be considered unsatisfactory if leakage is evident. The conduit entrances must be placed at least 24 inches (0.6 m) below the water surface. Any leakage of water into the assembly will be cause for rejection.

Note: This test is also to be performed on bases designed to be field height adjustable, but the extension does not have to be in place.

4.1.3 Type L-867 Class IA and Class IB Dimensional Tests.

Specimens must be measured for conformance to the dimensions specified in Figures 1, 2, 3, and 4. Should any new product be introduced that does not exactly conform to the fixed products shown, the applicable dimensions necessary to ensure compatibility with certified light fixtures and bases must be applied.

4.1.4 Type L-867 Class IA and Class IB Protective Coating Thickness Test.

When utilized, the thickness of protective coatings must equal or exceed those specified herein. The weight of hot-dip galvanizing must be tested according to the method described in ASTM A 153. Zinc plating thickness must be tested by a method described in ASTM B 633.

4.1.5 Type L-867 Class IA and Class IB Visual Inspection.

Each unit must be visually inspected for quality of workmanship and materials. The specified Class marking must be inspected for correctness. Particular attention must be given to smoothness and continuity of welds and seams, flatness and smoothness of the flange surface, complete and uniform application of the protective coating, freedom from excess zinc when applicable, and absence of burrs, sharp edges, cracks, voids, penetrations or any other imperfection that could potentially affect the structural integrity or performance of the product.

4.1.6 Type L-867 Class IB Potassium Acetate Test.

Light bases and extensions certified to Type L-867 Class IB requirements must be subjected to testing to determine if they are resistant to corrosion or deterioration caused by deicing fluids containing potassium acetate.

- The test consists of selecting a test light base and filling it half full with a potassium acetate deicing fluid composed of 50 percent potassium acetate and 50 percent water, by weight.
- The test light base will have conduit connecting devices identical to that to be furnished with the base with conduit stubs plugged and the top of the base must be covered with an appropriate blank cover and gasket.
- The test light base must remain for 21 days at an elevated temperature of 194°F (90°C).

- After the test period, the light base and spacer ring must be inspected. Any evidence of corrosion, leakage, or deterioration (peeling delamination, blistering) of coatings must be cause for rejection.

4.2 Type L-867 Class IIA and Class IIB Certification Testing.

Type L-867, Class IIA and Class IIB bases and extensions fabricated from materials to dimensions as specified herein must be capable of passing the following tests.

4.2.1 Type L-867 Class IIA and Class IIB Load Test.

Sample bases and extensions must be subjected to the load test described in paragraph 4.1.1.

4.2.2 Type L-867 Class IIA and Class IIB Weld Integrity Test.

Sample bases and extensions must be subjected to the leakage test described in paragraph 4.1.2.

Note: This test is also to be performed on bases designed to be field height adjustable, but the extension does not have to be in place.

4.2.3 Type L-867 Class IIA and Class IIB Temperature Shock Test.

Temperature shock test requirements apply only to Class II, non-metallic, Type L-867 bases.

- A temperature shock test must be conducted on a completed non-metallic base assembly.
- The test must be performed according to MIL-STD-810E, Method No. 503.2, Paragraph II, Procedure I.
- The high test temperature must be conducted at +130°F (+54°C) and the low test temperature must be conducted at -65°F (-54°C).
- This test must be conducted on the assembly after the load test described in paragraph 4.1.1 has been concluded.
- Any cracking or joint separation of the materials making up the base assembly will be cause for rejection.

4.2.4 Type L-867 Class IIA and Class IIB Dimensional Tests.

Specimens must be measured for conformance to the dimensions specified in Figures 1, 2, 3, and 4, as applicable.

- Mounting flange and base wall thicknesses must be measured and must be equal to or greater than those required to pass the load test and torque test described in paragraph 4.1.1.

- Should any new product be introduced that does not exactly conform to the fixed products shown, the applicable dimensions necessary to ensure compatibility with certified light fixtures and bases must be applied.

4.2.5 Type L-867 Class IIA and Class IIB Protective Coating Thickness Test.

For components of the base or assembly requiring protective coatings, the thickness of protective coatings must be tested in accordance with paragraph 4.1.4.

4.2.6 Type L-867 Class IIA and Class IIB Visual Inspection.

Bases must be visually inspected in accordance with paragraph 4.1.5.

4.2.7 Type L-867 Class IIB Potassium Acetate Test.

Light bases and extensions certified to Type L-867 Class IIB requirements must be subjected to testing to determine if they are resistant to corrosion caused by deicing fluids containing potassium acetate. The test must be conducted in accordance with paragraph 4.1.6.

4.2.8 Type L-894 Elevated Light Cover Load and Bending Moment Test.

A static load and bending moment test must be performed on an elevated light cover mated to an L-867 light base (or equivalent).

4.2.8.1 Type L-894 Test Load Application Method.

The test load must be applied to the top part of the test assembly through a rubber block of a diameter at least 1 inch (25.4 mm) less than the outside diameter of the light assembly. The rubber block must be 1.5 inches thick, \pm 0.25 in. thick and have a "Shore A" hardness of 55-70.

4.2.8.2 Type L-894 Test Load Application.

For elevated light covers, the load must be 2,500 pounds (1,134 kg). The load must be applied uniformly over the rubber block in paragraph 4.2.8.1.1 at a rate not greater than 10,000 pounds (4,536 kg) per minute. Full load must be applied for at least 1 minute.

4.2.8.3 Type L-894 Bending Moment.

When the elevated light cover is bolted to an L-867 light base, it must withstand a bending moment of 2,500 foot pounds (3,390 N·m) for the L-804 and 700 foot pounds (949 N·m) for all other applications.

4.2.8.4 Type L-894 Test Results.

The test is considered as unsatisfactory if there any permanent deformation, cracking of material or finish, breaking, or damage to the light, and/or elevated light cover.

4.2.9 Type L-895 Elevated Light Mounting Stake Dimensional Tests.

Verify that the dimensions of the mounting stake are per paragraphs 3.2.3.2 and 3.2.3.2.3.

4.2.9.1 Type L-895 Elevated Light Mounting Stake Protective Coatings.

Verify that all protective coatings are per paragraph 3.2.8.

4.3 Type L-868 Class IA and Class IB Certification Testing.

Type L-868, Class I bases and extensions fabricated with the materials and dimensions specified herein must pass the following tests.

4.3.1 Type L-868 Class IA and Class IB Load Test.

Sample bases and extensions must be subject to the load test described in paragraph 4.1.1 with the following exception. A load of 450 psi (3,103 kPa) must be applied uniformly over the area of the rubber block at a rate not to exceed 10,000 pounds (4,536 kg) per minute. The test section must be a unit in height deemed to be the maximum height, to be furnished by the manufacturer. For 8 inch (203 mm) Type L-868, one inch (25 mm) conduit entrances must be used.

4.3.2 Type L-868 Class IA and Class IB Fatigue Test.

If a material other than ASTM A36 steel is used for a major load-bearing structural component, the material must have a fatigue limit or endurance limit no less than 27 ksi (186 MPa). Specimens from the proposed material must be able to withstand a minimum of 5×10^7 cycles at 27 ksi (186 MPa) by a standard R.R. Moore rotating beam fatigue test using polished specimens. No less than three tests must be conducted to validate the material's fatigue properties.

4.3.3 Type L-868 Class IA and Class IB Impact Test.

If a material other than ASTM A36 steel is used for a major load-bearing structural component, the material must have an impact toughness equal to or greater than 15 ft-lb (20 J) at 20°F (-7°C), per the Charpy V-notch Test specified in ASTM E23. No less than three tests must be conducted to validate the material's impact properties.

4.3.4 Type L-868 Class IA and Class IB Flange Bolt Torque Test.

Flanges must be tested by inserting dry 3/8 inch X 16 threads per inch 18-8 stainless steel tap (fully threaded) bolts used to mount a typical in-pavement light fixture in all 6 bolt holes and torquing all bolts to failure.

Note: Check with a light fixture manufacturer for a typical bolt length used to mount in-pavement light fixtures.

Any cracking or permanent deformation of the flange material will be cause for rejection. Any rotation or distortion of installed remedial devices or replaceable inserts will also be cause for rejection.

4.3.5 Type L-868 Class IA and Class IB Weld Integrity Test.

Sample bases and extensions must be subjected to the leakage test described in paragraph 4.1.2.

Note: This test is also to be performed on bases designed to be field height adjustable, but the extension does not have to be in place.

4.3.6 Type L-868 Class IA and Class IB Dimensional Tests.

Specimens must be measured for conformance to the dimensions per Figures 5 through 9. Should any new product be introduced that does not exactly conform to the certified

products per this AC, the applicable dimensions necessary to ensure compatibility with currently certified light fixtures and bases must be applied.

4.3.7 Type L-868 Class IA and Class IB Protective Coating Thickness Test.

For components of the base or assembly requiring protective coatings, the thickness of protective coatings must be tested in accordance with paragraph 4.1.4.

4.3.8 Type L-868 Class IA and Class IB Visual Inspection.

Specimens must be subject to visual inspection as described in paragraph 4.1.5.

4.3.9 Type L-868 Class IB Potassium Acetate Test.

Bases and Extensions must be subjected to testing to determine if they are resistant to corrosion caused by deicing fluids containing potassium acetate. The test must be conducted in accordance with paragraph 4.1.6.

4.3.10 Type L-868 Torque Test for Adjustable Height Bases and Extensions.

Two different torque tests are specified depending on the intended application for Class IA and IB bases.

4.3.10.1 Base Anchored Into the Surrounding Pavement.

- The torque test must be performed on a specimen properly assembled and constructed so as to closely simulate actual installation in a pavement.
- Prior to test, reference “tick” marks must be made on the mounting flange and surrounding pavement material.
- A torque of 100,000 in-lbs (11,300 Nm) must be applied perpendicular to the vertical axis of the container through a steel cover plate. The maximum torque must be achieved within 60 seconds of the start of test.
- The torque load must be applied three times.
- Upon completion of the third torque loading, the reference “tick” marks will be measured to determine if the support ring has been displaced in azimuth. An azimuth displacement of 0.25 degree or greater must be cause for rejection.

4.3.10.2 Base Anchored into Embedment Material.

After completion of load testing, specimens must be subjected to torque testing as described in paragraph 4.3.10.1 to ensure adequate material thicknesses, attachment, and assembly techniques. An azimuth displacement of 0.25 degree or greater must be cause for rejection. Separation of the flange or bottom of the container from the body sidewalls, as well as buckling and/or permanent deformation of the body sidewalls must also be cause for rejection.

4.4 Production Testing.

4.4.1 Lot Size.

The lot size must be equal to the daily production rate.

4.4.2 Sample Size and Acceptance Criteria.

Production testing must be based on the procedures given in ANSI/ASQ Z1.4. Sample size and acceptance criteria must be based on Table 1 (Sample Size Code Letters), General Inspection Level I, Table II-A (Single Sampling Plans for Normal Inspection), and an Acceptable Quality Level (AQL) of 2.5. Note that normal inspection may be switched to reduced inspection provided the conditions set forth in ANSI/ASQ Z1.4 are met.

4.4.3 Retesting.

If the lot is rejected, the remainder of the lot may be tested and inspected on an individual basis. As an alternative to individual testing and inspection, the remainder of the lot may be tested using criteria in ANSI/ASQ Z1.4 for multiple sampling. Table IVB, Multiple Sampling Plans for Tightened Inspection, using the appropriate sample size and an AQL of 2.5, must be used. Should the lot fail under the multiple sampling plan criteria, all units must be inspected and tested individually and repaired as necessary. Any samples that fail under any of the above criteria must be repaired prior to shipment.

4.4.4 Type L-867, Class IA and Class IB.

4.4.4.1 Dimensional Tests.

Random samples from each lot must be subjected to dimensional tests as described in paragraph 4.1.3.

4.4.4.2 Visual Inspection.

Random samples from each lot must be subjected to visual inspection as described in paragraph 4.1.5.

4.4.4.3 Weld Integrity Test.

Random samples from each lot must be subjected to the leakage test described in paragraph 4.1.2, except that load testing of production samples is not required.

4.4.5 Type L-867 Class IIA and Class IIB.

4.4.5.1 Dimensional Tests.

Random samples from each lot must be tested in accordance with paragraph 4.2.4.

4.4.5.2 Visual Inspection.

Random samples from each lot must be visually inspected in accordance with paragraph 4.1.5.

4.4.5.3 Weld Integrity Test.

Random samples from each lot must be subjected to the leakage test described in paragraph 4.1.2, except that load testing of production samples is not required.

4.4.6 Type L-868 Class IA and Class IB.**4.4.6.1 Dimensional Test.**

Random samples from each lot must be tested for conformance to the dimensional test described in paragraph 4.3.6.

4.4.6.2 Visual Inspection.

Random samples from each lot must be inspected for conformance to the requirements in paragraph 4.3.8.

4.4.6.3 Weld Integrity Test.

Random samples from each lot must be subjected to the leakage test described in paragraph 4.1.2, except that load testing of production samples is not required.

This page intentionally left blank.

Chapter 5. PREPARATION FOR DELIVERY.

5.1 Packing.

Equipment must be carefully packaged for shipment and delivery to avoid damage and/or corrosion. Protective covers must be installed on all bases. (See paragraph 3.1.3.5.3.)

5.2 Marking.

Equipment must be marked for shipment with the consignee's name and address, and other pertinent information as needed by the installer. Marking must include the following statement, "Installer: These products have been packed and shipped per FAA recommendations. Products are to be handled carefully so no damage to the structure or finish will occur during the installation process."

Figure 1. Flange, Type L-867, Class IA, Class IB, Class IIA, Class IIB

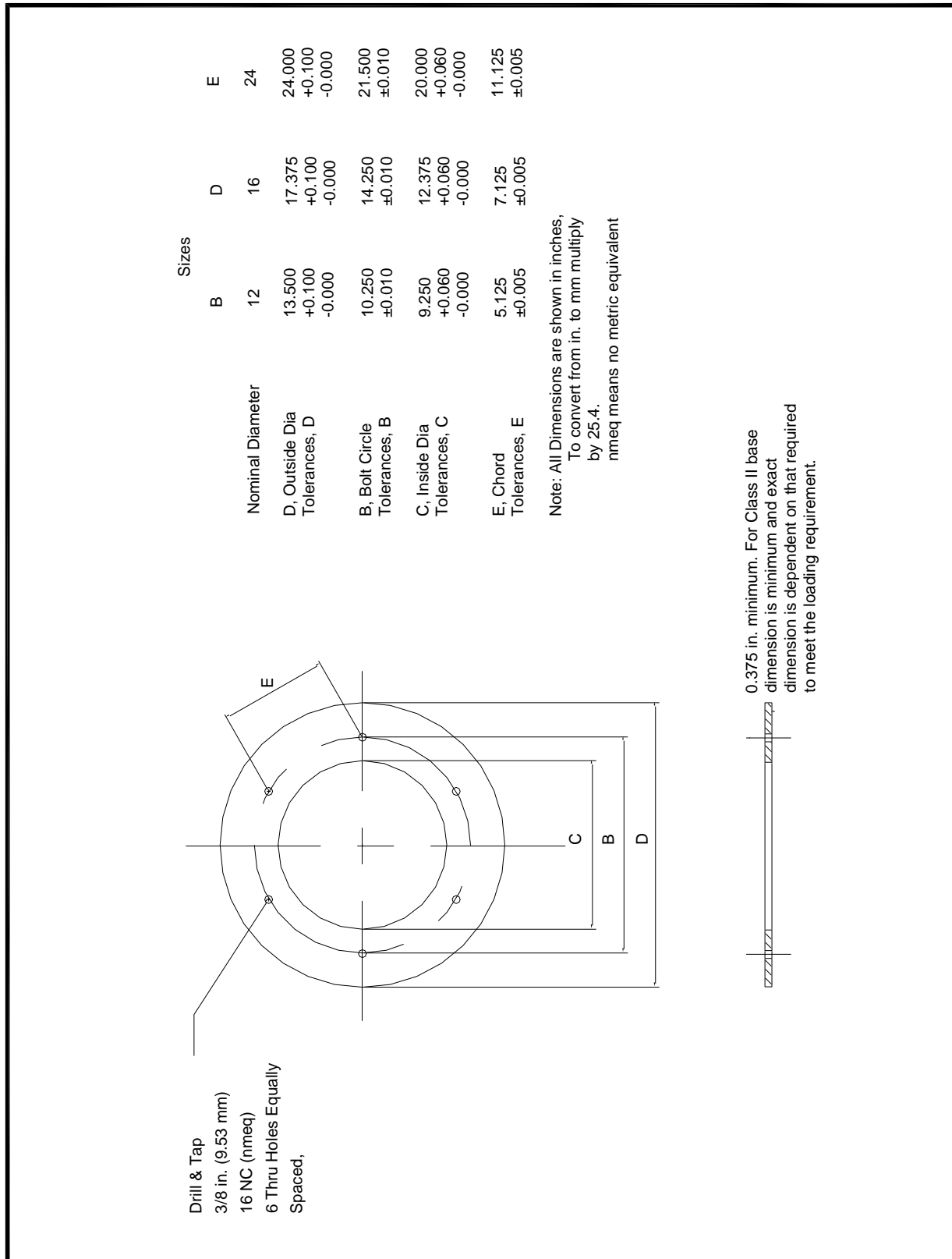

Figure 2. Body, Type L-867, Class IA, Class IB, Class IIA, Class IIB

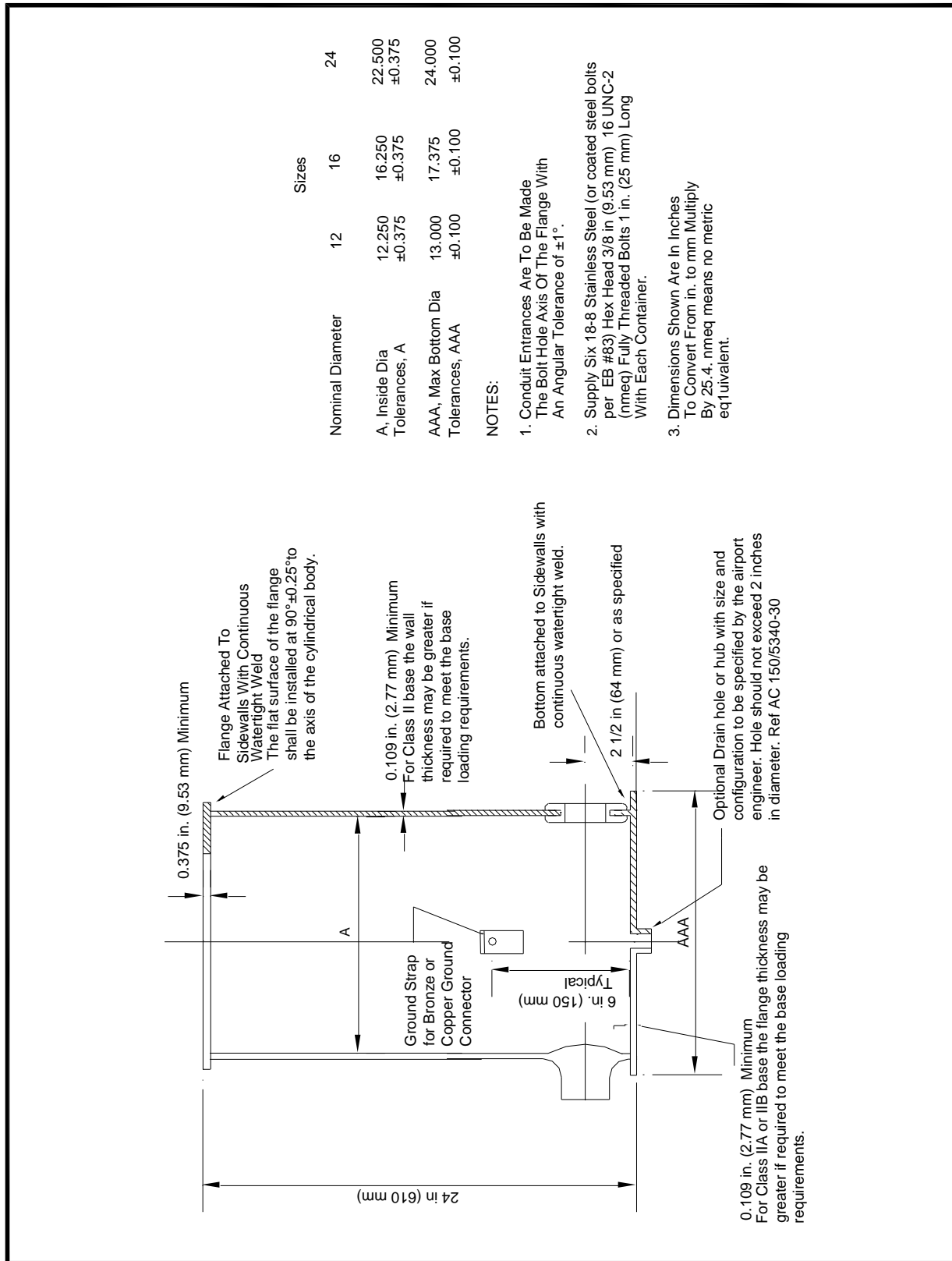

Figure 3. Extensions, Type L-867, Class IA, Class IB, Class IIA, Class IIB

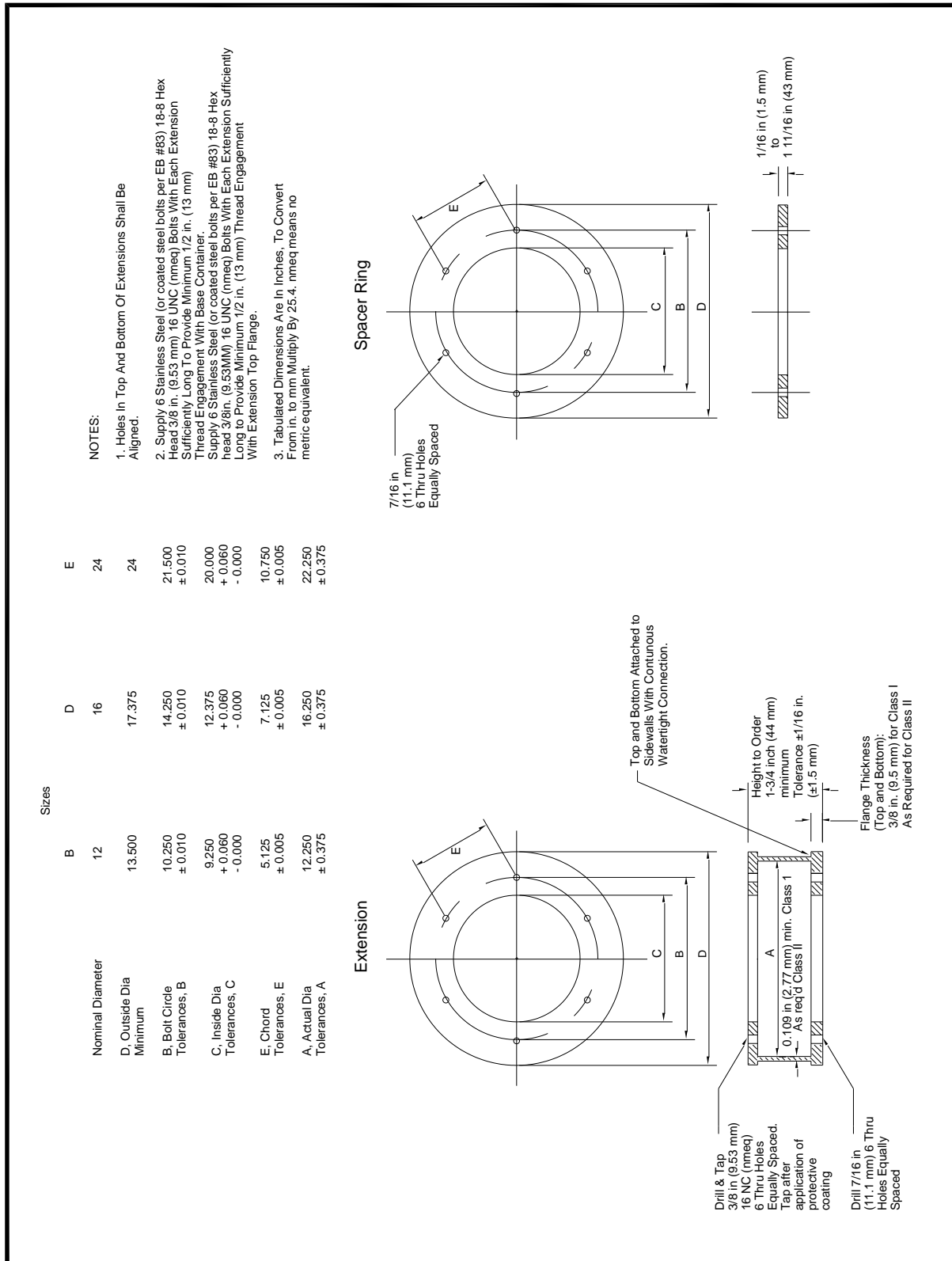

Figure 4. Accessories, Type L-867

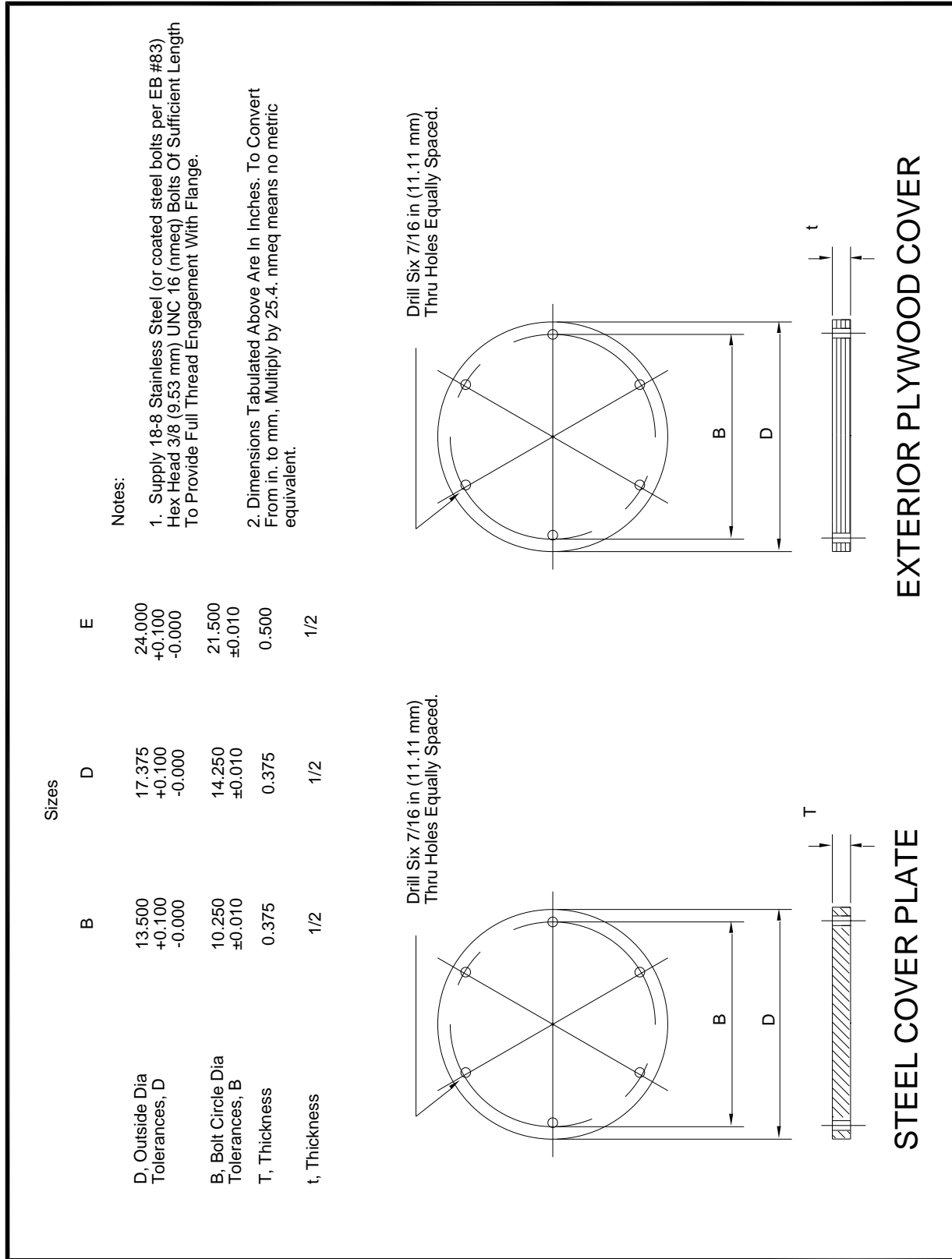

Figure 5. Flange, Type L-868, Class IA, Class IB

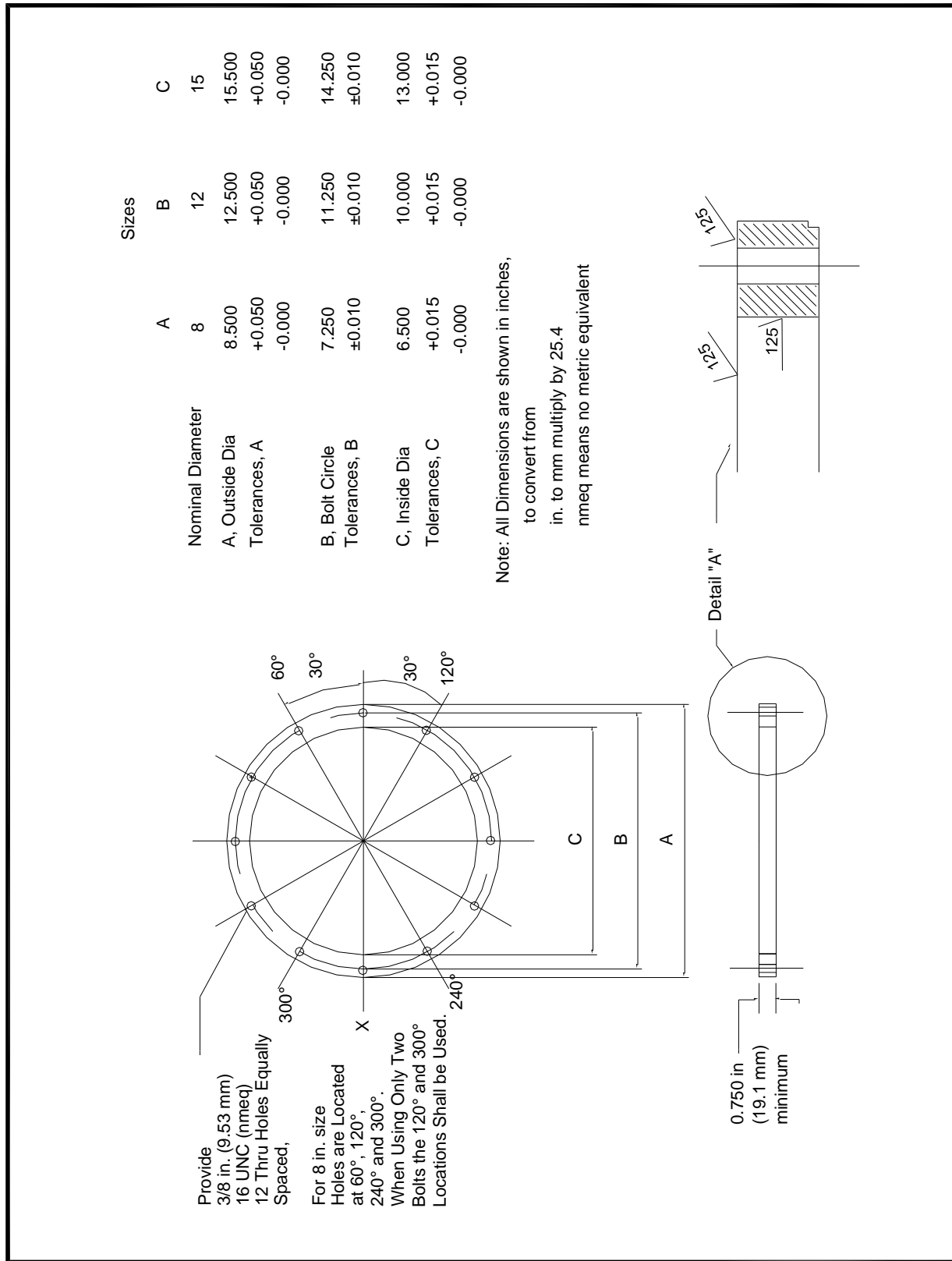

Figure 6. Body, Type L-868, Class IA, Class IB

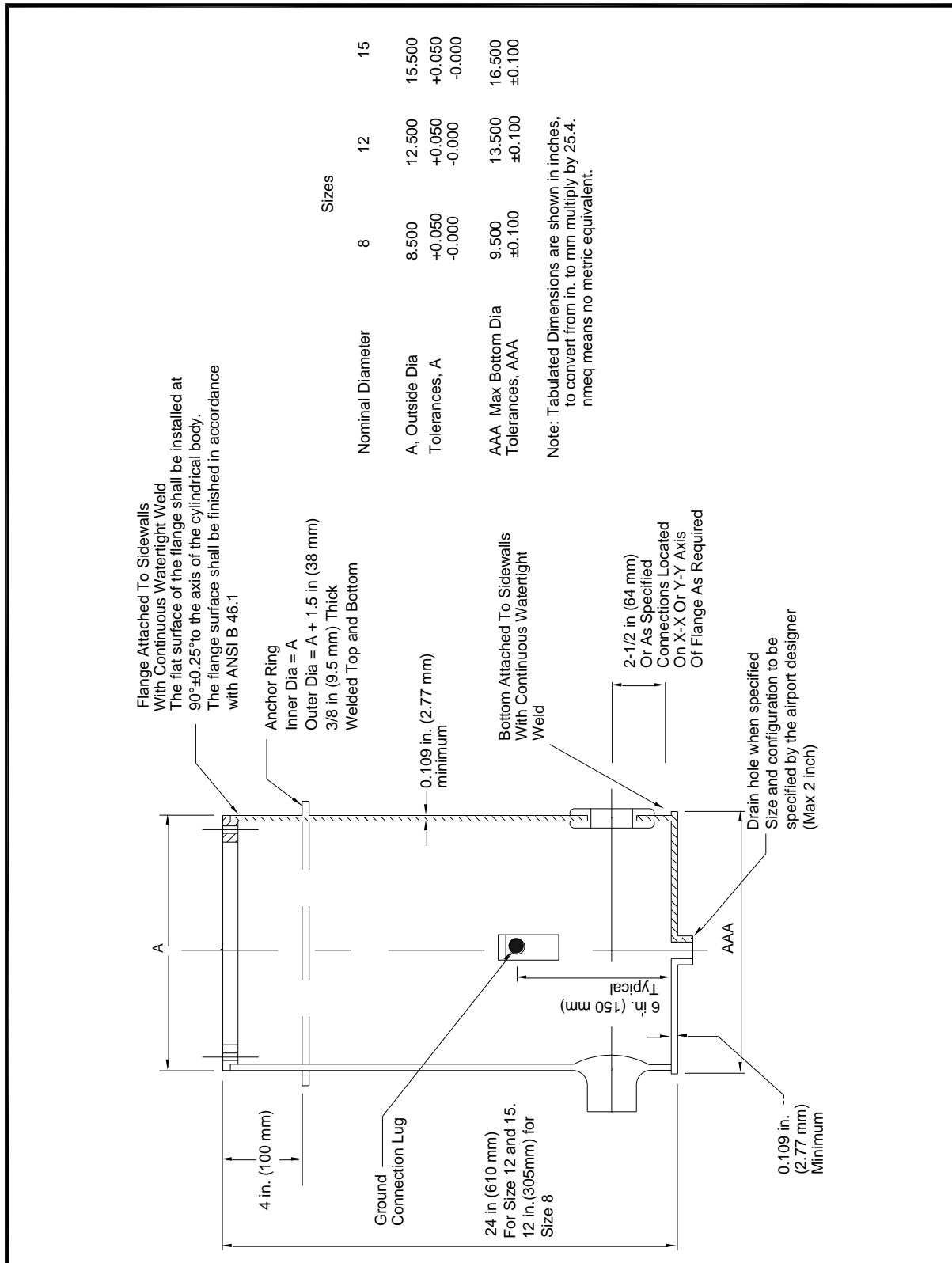

Figure 7. Sectional Body, Type L-868, Class IA, Class IB

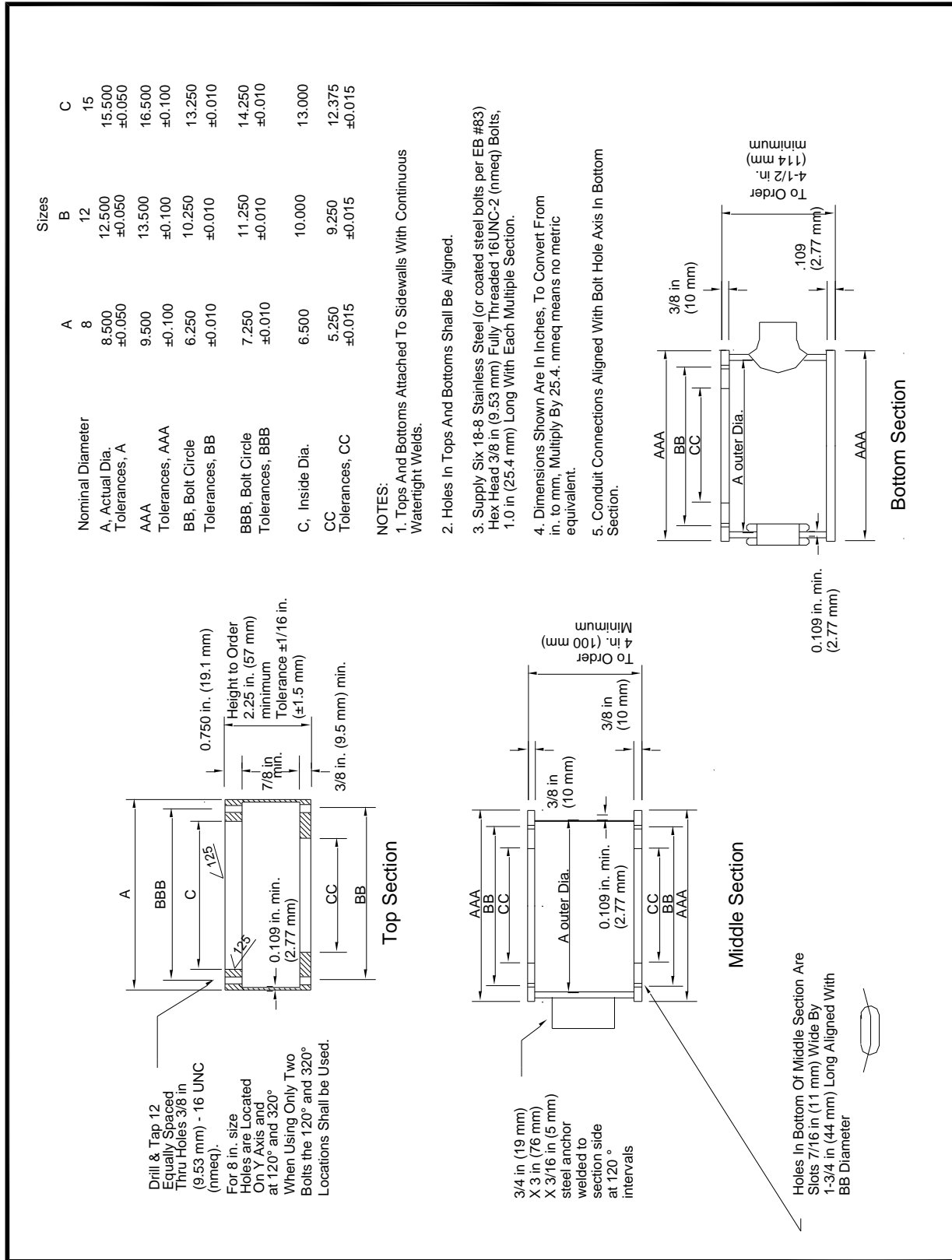
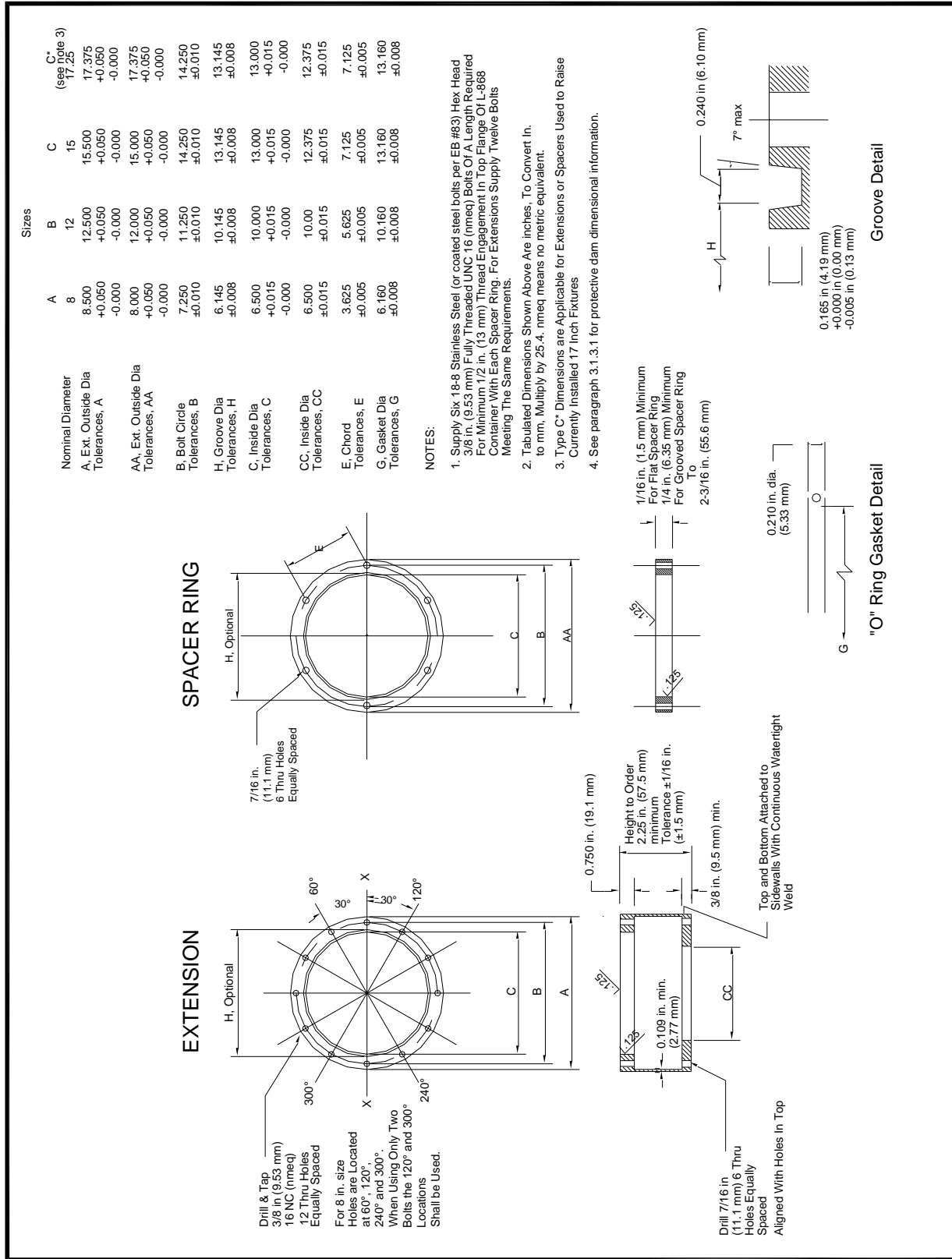
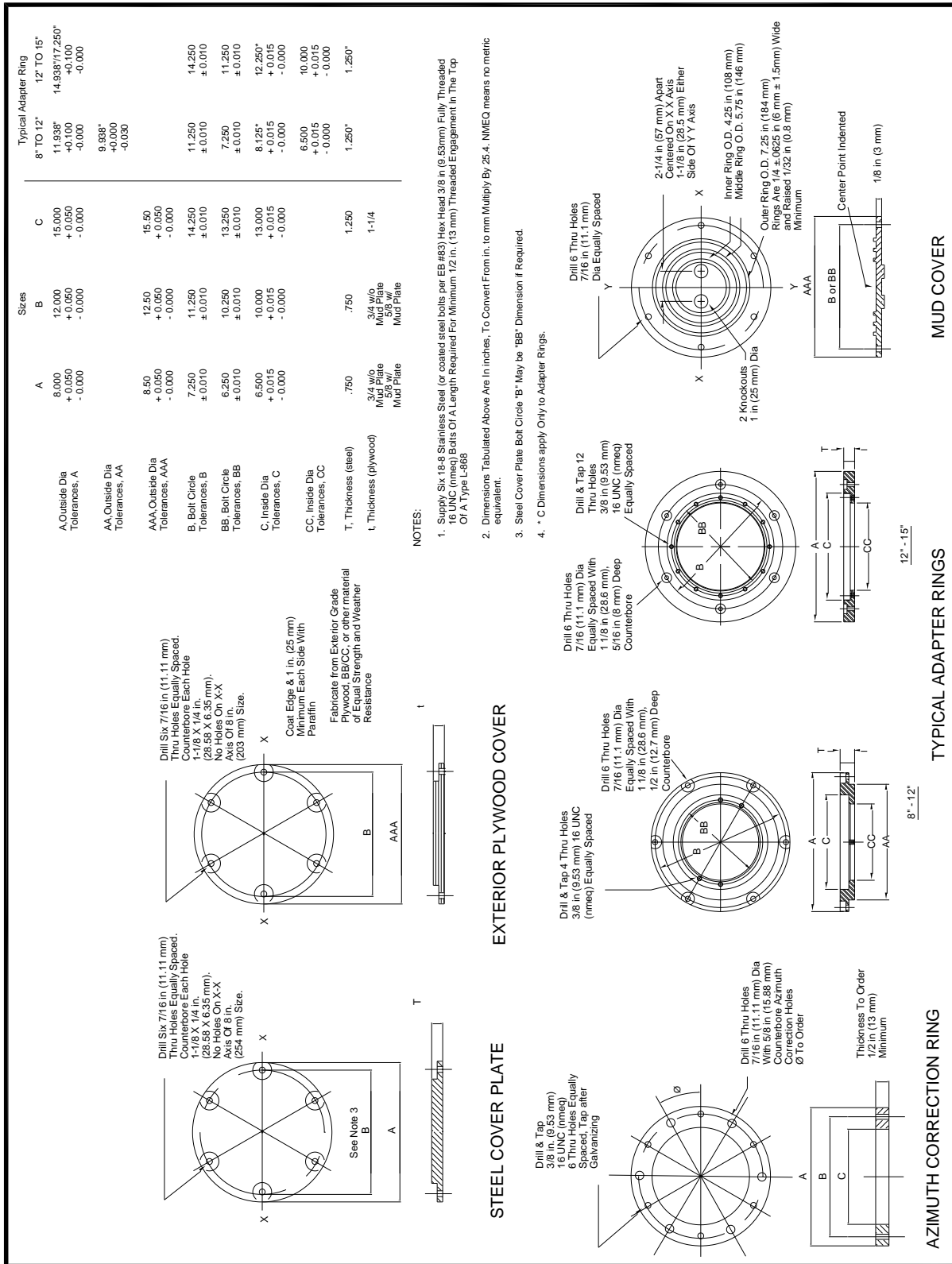

Figure 8. Extensions, Type L-868 Class IA, Class IB



	Sizes			
	A	B	C	C* (see note 3) 17.25
Nominal Diameter	8	12	15	
A, Ext. Outside Dia Tolerances, A	8.500 +0.050 -0.000	12.500 +0.050 -0.000	15.500 +0.050 -0.000	17.375 +0.050 -0.000
AA, Ext. Outside Dia Tolerances, AA	8.000 +0.050 -0.000	12.000 +0.050 -0.000	15.000 +0.050 -0.000	17.375 +0.050 -0.000
B, Bolt Circle Tolerances, B	7.250 ±0.010	11.250 ±0.010	14.250 ±0.010	14.250 ±0.010
H, Groove Dia Tolerances, H	6.145 ±0.008	10.145 ±0.008	13.145 ±0.008	13.145 ±0.008
C, Inside Dia Tolerances, C	6.500 +0.015 -0.000	10.000 +0.015 -0.000	13.000 +0.015 -0.000	13.000 +0.015 -0.000
CC, Inside Dia Tolerances, CC	6.500 ±0.015	10.000 ±0.015	12.375 ±0.015	12.375 ±0.015
E, Chord Tolerances, E	3.625 ±0.005	5.625 ±0.005	7.125 ±0.005	7.125 ±0.005
G, Gasket Dia Tolerances, G	6.160 ±0.008	10.160 ±0.008	13.160 ±0.008	13.160 ±0.008

Figure 9. Accessories, Type L-868



APPENDIX A. 10-INCH (254 MM) LIGHT BASE.

The 10 inch light base in this Appendix Figure is included for reference only.

Figure A-1. Extensions and Spacers for 10-inch (254 mm) Diameter Type L-868 Base, for Maintenance of Existing Installations Only

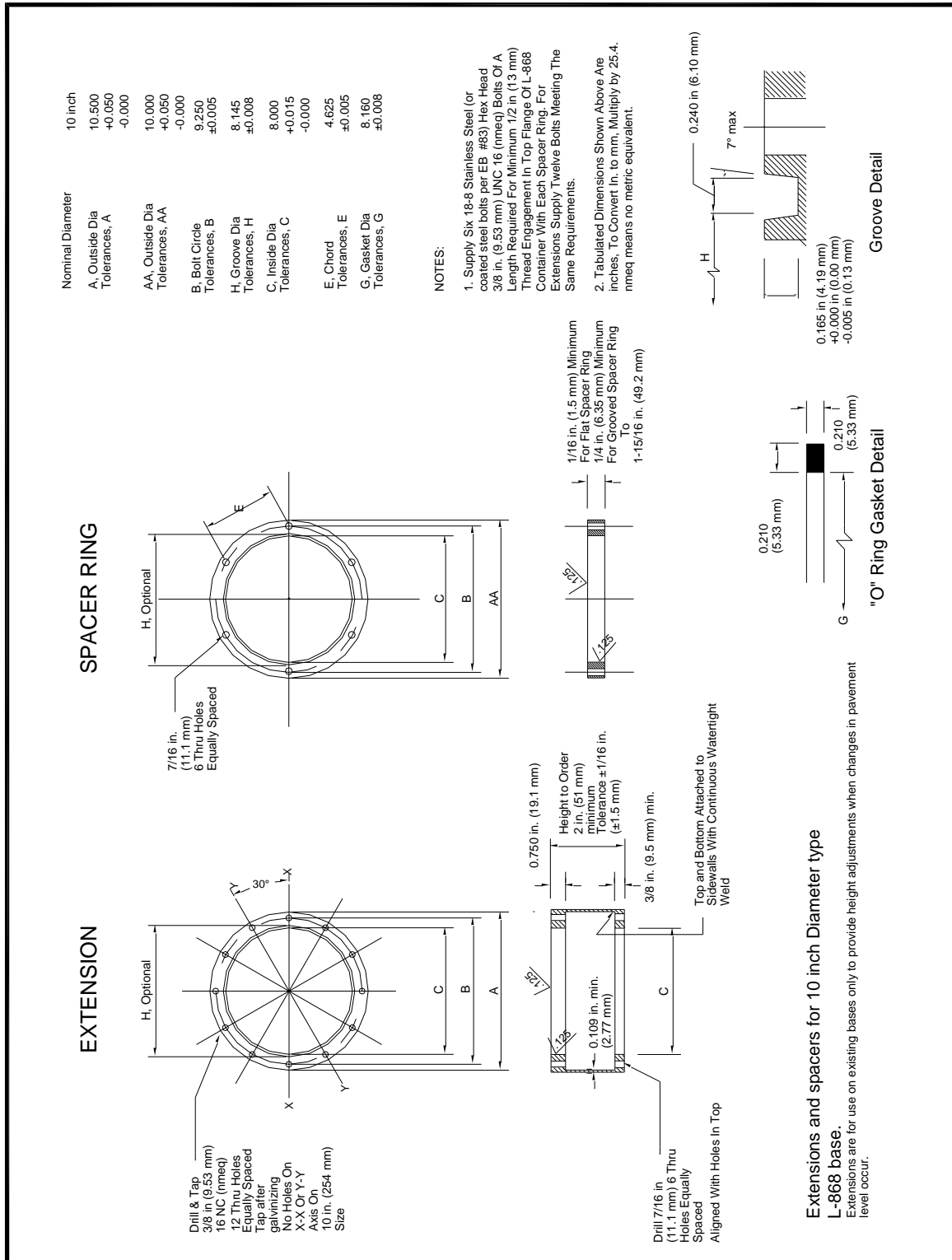

Advisory Circular Feedback

If you find an error in this AC, have recommendations for improving it, or have suggestions for new items/subjects to be added, you may let us know by (1) mailing this form to:

Federal Aviation Administration
Airport Engineering Division (AAS-100)
800 Independence Avenue SW
Washington, DC 20591

or (2) faxing it to the attention of Manager, Airport Engineering Division (AAS-100), (202) 267-3688.

Subject: AC 150/5345-42H, *Specification for Airport Light Bases, Transformer Housings, Junction Boxes, and Accessories* **Date:** _____

Please check all appropriate line items:

An error (procedural or typographical) has been noted in paragraph _____ on page _____.

Recommend paragraph _____ on page _____ be changed as follows:

In a future change to this AC, please cover the following subject:
(Briefly describe what you want added.)

Other comments:

I would like to discuss the above. Please contact me at (phone number, email address).

Submitted by: _____ Date: _____

This page intentionally left blank.