

INCH-POUND

MS21251M
w/Amendment 1
1 April 2005
SUPERSEDING
MS21251M
20 November 2002

DETAIL SPECIFICATION SHEET
TURNBUCKLE BODY, CLIP LOCKING

This specification is approved for use by all Departments and Agencies of the Department of Defense.

The requirements for acquiring the product described herein shall consist of this specification sheet, MIL-DTL-8878, and QPL-8878.

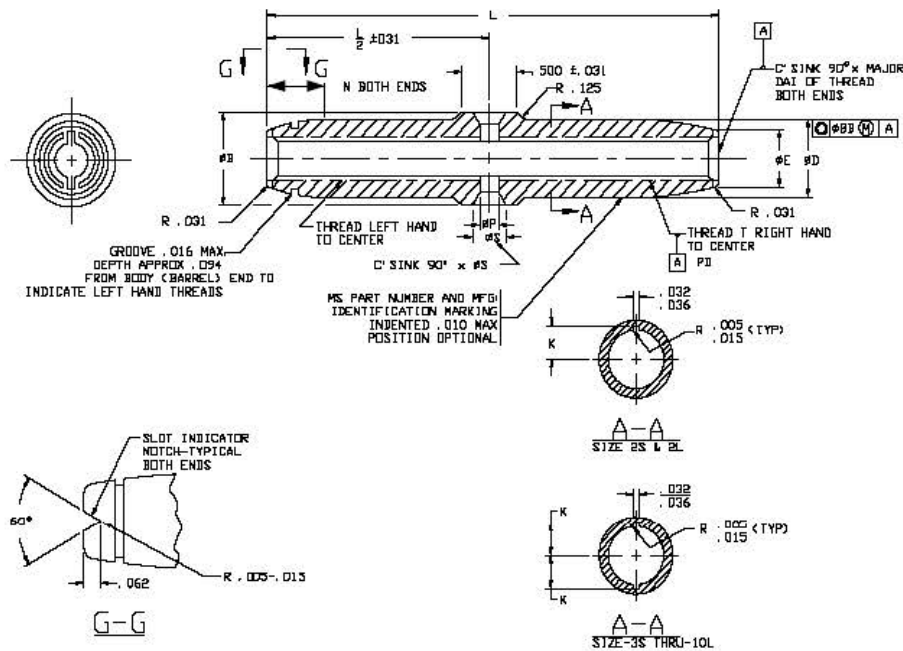

NOTE:

1. The notch shall align within the width of the slot.

FIGURE 1. Turnbuckle body, clip locking.

MS21251M
w/Amendment 1

TABLE I. Dash numbers and dimensions.

Dash number			Wire rope diameter		Minimum breaking strength lbs.	Thread T UNF-3B	L ±0.031	ØB ±0.005	N ±0.031	ØD ±0.005	ØE ±0.005	K		ØS	ØP ±0.005	ØBB	Applicable Locking clip MS21256	
Steel	Brass	Aluminum	Nominal reference	Minimum								Minimum	Minimum					Maximum
2S	B2S	A2S	1/16	0.062	800	0.1380 (#6)-40	2.250	0.250	0.156	0.219	0.188	0.0749	0.0807	0.187	0.125	0.020	FIM	-1
2L	B2L	A2L					4.000											-2
3S	B3S	A3S	3/32	0.093	1,600	0.1900 (#10)-32	2.250	0.344	0.188	0.281	0.250	0.1009	0.1048	0.187	0.125	0.020	FIM	-1
3L	B3L	A3L					4.000											-2
5S	B5S	A5S	5/32	0.156	3,200	0.2500 (1/4)-28	2.250	0.438	0.312	0.391	0.328	0.1294	0.1334	0.187	0.125	0.020	FIM	-1
5L	B5L	A5L	1/				4.000											-2
6S	B6S	A6S	3/16	0.187	4,600	0.3125 (5/16)-24	2.250	0.500	0.375	0.438	0.406	0.1587	0.1627	0.187	0.125	0.020	FIM	-1
6L	B6L	A6L					4.000											-2
8L	B8L	A8L	1/4	0.250	8,000	0.3750 (3/8)-24	4.000	0.625	0.500	0.594	0.489	0.1900	0.1939	0.187	0.125	0.020	FIM	-2
9L	B9L	A9L	9/32	0.281	12,750	0.4375 (7/16)-20	4.250	0.750	0.594	0.688	0.563	0.2185	0.2225	0.250	0.188	0.020	FIM	-3
10L	B10L	A10L	5/16	0.312	17,500	0.5000 (1/2)-20	4.250	0.875	0.656	0.813	0.625	0.2498	0.2537	0.250	0.188	0.020	FIM	-3

1/ See note 6.

REQUIREMENTS:

1. Material and protective treatment: Material and protective treatment shall be in accordance with MIL-DTL-8878.
2. Finish: Surface finish shall be RMS 125 or better.
3. Threads: Threads shall be in accordance with FED-STD-H28/20.
4. Bodies (barrels): Bodies (barrels) shall be marked with the year of manufacture.
5. Marking: Marking by impression stamping (or any other stress inducing method), if used, shall be done before stress relieving.
6. Tolerances: Unless otherwise specified, tolerances: decimals ± 0.010, angles ± 3°.

NOTES:

(This section contains information of a general or explanatory nature that may be helpful, but is not mandatory.)

1. The part or identifying number (PIN) to be used for turnbuckles acquired to this specification is created as shown below. The first letter of the dash number indicates material, the second number refers to the size, and the third letter indicates length (short or long).

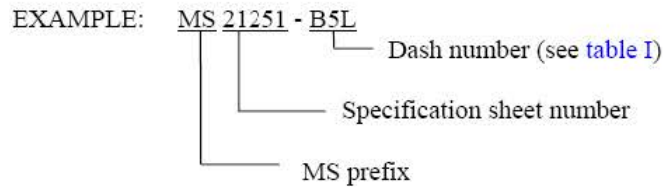

MS21251-B5L Indicates - Body (barrel), turnbuckle, brass, 0.2500 (1/4)-28 thread, long.

MS21251M
w/Amendment 1

2. Dimensions are in inches.
3. Remove burrs and break sharp edges. (See MIL-DTL-8878.)
4. Interpret drawing in accordance with ASME Y14.5M.
5. For clip locking of turnbuckles, see MS33736 and MIL-DTL-8878.
6. For 0.125 (1/8) inch diameter wire rope use -5 parts, minimum breaking strength 2,200 pounds (lbs.) (reference).
7. A turnbuckle with a manufacturing date of 1978 or older shall not be used for replacement repairs since stress relieving was not required prior to this date.
8. In the event of a conflict between the text of this document and the references cited herein, the text of this document takes precedence.
9. Unless otherwise specified, issues of referenced documents are those in effect at the time of solicitation.

AMENDMENT ANNOTATIONS: The margins of this specification are marked with vertical lines to indicate where modifications from this amendment were made. This was done as a convenience only and the Government assumes no liability whatsoever for any inaccuracies in these notations. Bidders and contractors are cautioned to evaluate the requirements of this document based on the entire content irrespective of the marginal notations.

Custodians:
Army - AV
Navy - AS
Air Force - 99

Preparing Activity:
DLA - GS5

(Project 1640-0007)

Review Activities:
Navy - MC
Air Force - 71

NOTE: The activities listed above were interested in this document as of the date of this document. Since organizations and responsibilities can change, you should verify the currency of the information above using the ASSIST database at <http://assist.daps.dla.mil/>.