



U.S. Department
of Transportation
**Federal Aviation
Administration**

800 Independence Ave., S.W.
Washington, D.C. 20591

June 30, 2015

Exemption No. 11945
Regulatory Docket No. FAA-2015-1457

Mr. Jeffrey J. Antonelli
Counsel for Home Debut, Inc., d/b/a TourFactory
35 East Wacker Drive
Suite 1875
Chicago, IL 60601

Dear Mr. Antonelli:

This letter is to inform you that we have granted your request for exemption. It transmits our decision, explains its basis, and gives you the conditions and limitations of the exemption, including the date it ends.

By letter dated April 21, 2015, you petitioned the Federal Aviation Administration (FAA) on behalf of Home Debut, Inc., d/b/a TourFactory (hereinafter petitioner or operator) for an exemption. The petitioner requested to operate an unmanned aircraft system (UAS) to conduct real estate photography.

See Appendix A for the petition submitted to the FAA describing the proposed operations and the regulations that the petitioner seeks an exemption.

The FAA has determined that good cause exists for not publishing a summary of the petition in the Federal Register because the requested exemption would not set a precedent, and any delay in acting on this petition would be detrimental to the petitioner.

Airworthiness Certification

The UAS proposed by the petitioner are the DJI Phantom 1, DJI Phantom 2, DJI Phantom 2 Vision, and DJI Phantom 2 Vision+.

The petitioner requested relief from 14 CFR part 21, *Certification procedures for products and parts, Subpart H—Airworthiness Certificates*. In accordance with the statutory criteria

provided in Section 333 of Public Law 112–95 in reference to 49 U.S.C. § 44704, and in consideration of the size, weight, speed, and limited operating area associated with the aircraft and its operation, the Secretary of Transportation has determined that this aircraft meets the conditions of Section 333. Therefore, the FAA finds that the requested relief from 14 CFR part 21, *Certification procedures for products and parts, Subpart H—Airworthiness Certificates*, and any associated noise certification and testing requirements of part 36, is not necessary.

The Basis for Our Decision

You have requested to use a UAS for aerial data collection¹. The FAA has issued grants of exemption in circumstances similar in all material respects to those presented in your petition. In Grants of Exemption Nos. 11062 to Astraesus Aerial (*see* Docket No. FAA–2014–0352), 11109 to Clayco, Inc. (*see* Docket No. FAA–2014–0507), 11112 to VDOS Global, LLC (*see* Docket No. FAA–2014–0382), and 11213 to Aeryon Labs, Inc. (*see* Docket No. FAA–2014–0642), the FAA found that the enhanced safety achieved using an unmanned aircraft (UA) with the specifications described by the petitioner and carrying no passengers or crew, rather than a manned aircraft of significantly greater proportions, carrying crew in addition to flammable fuel, gives the FAA good cause to find that the UAS operation enabled by this exemption is in the public interest.

Having reviewed your reasons for requesting an exemption, I find that—

- They are similar in all material respects to relief previously requested in Grant of Exemption Nos. 11062, 11109, 11112, and 11213;
- The reasons stated by the FAA for granting Exemption Nos. 11062, 11109, 11112, and 11213 also apply to the situation you present; and
- A grant of exemption is in the public interest.

Our Decision

In consideration of the foregoing, I find that a grant of exemption is in the public interest. Therefore, pursuant to the authority contained in 49 U.S.C. 106(f), 40113, and 44701, delegated to me by the Administrator, Home Debut, Inc., d/b/a TourFactory is granted an exemption from 14 CFR §§ 61.23(a) and (c), 61.101(e)(4) and (5), 61.113(a), 61.315(a), 91.7(a), 91.119(c), 91.121, 91.151(a)(1), 91.405(a), 91.407(a)(1), 91.409(a)(1) and (2), and 91.417(a) and (b), to the extent necessary to allow the petitioner to operate a UAS to perform aerial data collection. This exemption is subject to the conditions and limitations listed below.

¹ Aerial data collection includes any remote sensing and measuring by an instrument(s) aboard the UA. Examples include imagery (photography, video, infrared, etc.), electronic measurement (precision surveying, RF analysis, etc.), chemical measurement (particulate measurement, etc.), or any other gathering of data by instruments aboard the UA.

Conditions and Limitations

In this grant of exemption, Home Debut, Inc., d/b/a TourFactory is hereafter referred to as the operator.

Failure to comply with any of the conditions and limitations of this grant of exemption will be grounds for the immediate suspension or rescission of this exemption.

1. Operations authorized by this grant of exemption are limited to the DJI Phantom 1, DJI Phantom 2, DJI Phantom 2 Vision, and DJI Phantom 2 Vision+ when weighing less than 55 pounds including payload. Proposed operations of any other aircraft will require a new petition or a petition to amend this exemption.
2. Operations for the purpose of closed-set motion picture and television filming are not permitted.
3. The UA may not be operated at a speed exceeding 87 knots (100 miles per hour). The exemption holder may use either groundspeed or calibrated airspeed to determine compliance with the 87 knot speed restriction. In no case will the UA be operated at airspeeds greater than the maximum UA operating airspeed recommended by the aircraft manufacturer.
4. The UA must be operated at an altitude of no more than 400 feet above ground level (AGL). Altitude must be reported in feet AGL.
5. The UA must be operated within visual line of sight (VLOS) of the PIC at all times. This requires the PIC to be able to use human vision unaided by any device other than corrective lenses, as specified on the PIC's FAA-issued airman medical certificate or U.S. driver's license.
6. All operations must utilize a visual observer (VO). The UA must be operated within the visual line of sight (VLOS) of the PIC and VO at all times. The VO may be used to satisfy the VLOS requirement as long as the PIC always maintains VLOS capability. The VO and PIC must be able to communicate verbally at all times; electronic messaging or texting is not permitted during flight operations. The PIC must be designated before the flight and cannot transfer his or her designation for the duration of the flight. The PIC must ensure that the VO can perform the duties required of the VO.
7. This exemption and all documents needed to operate the UAS and conduct its operations in accordance with the conditions and limitations stated in this grant of exemption, are hereinafter referred to as the operating documents. The operating documents must be accessible during UAS operations and made available to the

Administrator upon request. If a discrepancy exists between the conditions and limitations in this exemption and the procedures outlined in the operating documents, the conditions and limitations herein take precedence and must be followed.

Otherwise, the operator must follow the procedures as outlined in its operating documents. The operator may update or revise its operating documents. It is the operator's responsibility to track such revisions and present updated and revised documents to the Administrator or any law enforcement official upon request. The operator must also present updated and revised documents if it petitions for extension or amendment to this grant of exemption. If the operator determines that any update or revision would affect the basis upon which the FAA granted this exemption, then the operator must petition for an amendment to its grant of exemption. The FAA's UAS Integration Office (AFS-80) may be contacted if questions arise regarding updates or revisions to the operating documents.

8. Any UAS that has undergone maintenance or alterations that affect the UAS operation or flight characteristics, e.g., replacement of a flight critical component, must undergo a functional test flight prior to conducting further operations under this exemption. Functional test flights may only be conducted by a PIC with a VO and must remain at least 500 feet from other people. The functional test flight must be conducted in such a manner so as to not pose an undue hazard to persons and property.
9. The operator is responsible for maintaining and inspecting the UAS to ensure that it is in a condition for safe operation.
10. Prior to each flight, the PIC must conduct a pre-flight inspection and determine the UAS is in a condition for safe flight. The pre-flight inspection must account for all potential discrepancies, e.g., inoperable components, items, or equipment. If the inspection reveals a condition that affects the safe operation of the UAS, the aircraft is prohibited from operating until the necessary maintenance has been performed and the UAS is found to be in a condition for safe flight.
11. The operator must follow the UAS manufacturer's maintenance, overhaul, replacement, inspection, and life limit requirements for the aircraft and aircraft components.
12. Each UAS operated under this exemption must comply with all manufacturer safety bulletins.
13. Under this grant of exemption, a PIC must hold either an airline transport, commercial, private, recreational, or sport pilot certificate. The PIC must also hold a current FAA airman medical certificate or a valid U.S. driver's license issued by a state, the District of Columbia, Puerto Rico, a territory, a possession, or the Federal government. The PIC must also meet the flight review requirements specified in 14 CFR § 61.56 in an aircraft in which the PIC is rated on his or her pilot certificate.

14. The operator may not permit any PIC to operate unless the PIC demonstrates the ability to safely operate the UAS in a manner consistent with how the UAS will be operated under this exemption, including evasive and emergency maneuvers and maintaining appropriate distances from persons, vessels, vehicles and structures. PIC qualification flight hours and currency must be logged in a manner consistent with 14 CFR § 61.51(b). Flights for the purposes of training the operator's PICs and VOs (training, proficiency, and experience-building) and determining the PIC's ability to safely operate the UAS in a manner consistent with how the UAS will be operated under this exemption are permitted under the terms of this exemption. However, training operations may only be conducted during dedicated training sessions. During training, proficiency, and experience-building flights, all persons not essential for flight operations are considered nonparticipants, and the PIC must operate the UA with appropriate distance from nonparticipants in accordance with 14 CFR § 91.119.
15. UAS operations may not be conducted during night, as defined in 14 CFR § 1.1. All operations must be conducted under visual meteorological conditions (VMC). Flights under special visual flight rules (SVFR) are not authorized.
16. The UA may not operate within 5 nautical miles of an airport reference point (ARP) as denoted in the current FAA Airport/Facility Directory (AFD) or for airports not denoted with an ARP, the center of the airport symbol as denoted on the current FAA-published aeronautical chart, unless a letter of agreement with that airport's management is obtained or otherwise permitted by a COA issued to the exemption holder. The letter of agreement with the airport management must be made available to the Administrator or any law enforcement official upon request.
17. The UA may not be operated less than 500 feet below or less than 2,000 feet horizontally from a cloud or when visibility is less than 3 statute miles from the PIC.
18. If the UAS loses communications or loses its GPS signal, the UA must return to a pre-determined location within the private or controlled-access property.
19. The PIC must abort the flight in the event of unpredicted obstacles or emergencies.
20. The PIC is prohibited from beginning a flight unless (considering wind and forecast weather conditions) there is enough available power for the UA to conduct the intended operation and to operate after that for at least five minutes or with the reserve power recommended by the manufacturer if greater.
21. Air Traffic Organization (ATO) Certificate of Waiver or Authorization (COA). All operations shall be conducted in accordance with an ATO-issued COA. The exemption holder may apply for a new or amended COA if it intends to conduct operations that cannot be conducted under the terms of the attached COA.

22. All aircraft operated in accordance with this exemption must be identified by serial number, registered in accordance with 14 CFR part 47, and have identification (N-Number) markings in accordance with 14 CFR part 45, Subpart C. Markings must be as large as practicable.
23. Documents used by the operator to ensure the safe operation and flight of the UAS and any documents required under 14 CFR §§ 91.9 and 91.203 must be available to the PIC at the Ground Control Station of the UAS any time the aircraft is operating. These documents must be made available to the Administrator or any law enforcement official upon request.
24. The UA must remain clear and give way to all manned aviation operations and activities at all times.
25. The UAS may not be operated by the PIC from any moving device or vehicle.
26. All Flight operations must be conducted at least 500 feet from all nonparticipating persons, vessels, vehicles, and structures unless:
 - a. Barriers or structures are present that sufficiently protect nonparticipating persons from the UA and/or debris in the event of an accident. The operator must ensure that nonparticipating persons remain under such protection. If a situation arises where nonparticipating persons leave such protection and are within 500 feet of the UA, flight operations must cease immediately in a manner ensuring the safety of nonparticipating persons; and
 - b. The owner/controller of any vessels, vehicles or structures has granted permission for operating closer to those objects and the PIC has made a safety assessment of the risk of operating closer to those objects and determined that it does not present an undue hazard.

The PIC, VO, operator trainees or essential persons are not considered nonparticipating persons under this exemption.

27. All operations shall be conducted over private or controlled-access property with permission from the property owner/controller or authorized representative. Permission from property owner/controller or authorized representative will be obtained for each flight to be conducted.
28. Any incident, accident, or flight operation that transgresses the lateral or vertical boundaries of the operational area as defined by the applicable COA must be reported to the FAA's UAS Integration Office (AFS-80) within 24 hours. Accidents must be reported to the National Transportation Safety Board (NTSB) per instructions contained on the NTSB Web site: www.nts.gov.

If this exemption permits operations for the purpose of closed-set motion picture and television filming and production, the following additional conditions and limitations apply.

29. The operator must have a motion picture and television operations manual (MPTOM) as documented in this grant of exemption.
30. At least 3 days before aerial filming, the operator of the UAS affected by this exemption must submit a written Plan of Activities to the local Flight Standards District Office (FSDO) with jurisdiction over the area of proposed filming. The 3-day notification may be waived with the concurrence of the FSDO. The plan of activities must include at least the following:
 - a. Dates and times for all flights;
 - b. Name and phone number of the operator for the UAS aerial filming conducted under this grant of exemption;
 - c. Name and phone number of the person responsible for the on-scene operation of the UAS;
 - d. Make, model, and serial or N-Number of UAS to be used;
 - e. Name and certificate number of UAS PICs involved in the aerial filming;
 - f. A statement that the operator has obtained permission from property owners and/or local officials to conduct the filming production event; the list of those who gave permission must be made available to the inspector upon request;
 - g. Signature of exemption holder or representative; and
 - h. A description of the flight activity, including maps or diagrams of any area, city, town, county, and/or state over which filming will be conducted and the altitudes essential to accomplish the operation.
31. Flight operations may be conducted closer than 500 feet from participating persons consenting to be involved and necessary for the filming production, as specified in the exemption holder's MPTOM.

Unless otherwise specified in this grant of exemption, the UAS, the UAS PIC, and the UAS operations must comply with all applicable parts of 14 CFR including, but not limited to, parts 45, 47, 61, and 91.

This exemption terminates on July 31, 2017, unless sooner superseded or rescinded.

Sincerely,

John S. Duncan
Director, Flight Standards Service

Enclosures

ANTONELLI LAW

Drone/UAS Practice Group

35 East Wacker Drive
Suite 1875
Chicago, IL 60601
Tel. 312.201.8310
Jeffrey@Antonelli-Law.com

U.S. Department of Transportation
Docket Management System
1200 New Jersey Ave S.E.
Washington, D.C. 20590

April 21, 2015

Re: Request for Exemption under Section 333 of the FAA Modernization and Reform Act of 2012 and Part 11 of the Federal Aviation Regulations from Certain Provisions of 14 C.F.R.

Dear Sir or Madam:

Pursuant to Section 333 of the FAA Modernization and Reform Act of 2012 (the Reform Act) and 14 C.F.R. Part 11, Antonelli Law files this petition for exemption on behalf of Home Debut Inc., d/b/a TourFactory (“TourFactory”), an operator of Small Unmanned Aircraft Systems (“UAs”) used for real estate photography. Specifically, petitioner seeks an exemption from the Federal Aviation Regulations (“FARs”) listed in Appendices A and B to allow commercial operation of its UAs, so long as such operations are conducted within and under the conditions outlined herein or as may be established by the FAA in a grant of this petition. This request is substantially similar to other data collection petitions previously approved, and should be considered under the expedited summary grant procedure. Additionally, this petition should be eligible for the summary grant because of the voluntary altitude restriction to 200 feet above ground level (AGL).

Approval of the exemption for petitioner will allow commercial operation of the DJI Phantom 1, Phantom 2, Phantom 2 Vision, and Phantom 2 Vision+ for real estate photography in Class G airspace nationwide, or as otherwise prescribed by an Air Traffic Organization (ATO) issued COA. The UA covered by this petition is a small battery-powered craft, weighing between approximately 2.2 lbs. (1 kg.) and 2.74 lbs. (1.24 kg.), inclusive of battery and payload. Operation of the UAs under the strict conditions proposed below will provide an equivalent level of safety, as Congress intended, while still allowing commercial operations. Operations using these UAs are far safer than conventional operations conducted with helicopters and fixed-wing aircraft that weigh thousands of pounds, carry highly flammable fuel, and operate in close proximity to the ground, trees, infrastructure, and people.

Congress directed the FAA to consider seven factors in deciding whether to approve Section 333 exemption petitions - size, weight, speed, operational capability, proximity to airports, proximity to populated areas, and operation within visual line of sight. In this case, each factor supports the exemption request. In particular, the UA is small, and will operate at

slow speeds and close to the ground. It will be able to more safely and efficiently take aerial photography of real estate. The substantial increase of safety and decrease of risk to human life and to property weighs heavily in favor of granting the exemption.

Pursuant to 14 C.F.R. §11.35, petitioner requests confidential treatment for certain information provided with this request for exemption. Specifically, petitioner is submitting its proprietary UAS Policy under separate cover as Exhibit 1. It requests that the information contained in that exhibit not be made public because it contains trade secrets whose disclosure would harm petitioner. The exhibit contains valuable commercial data this is not publicly available and is protected from release under the Freedom of Information Act, 5 U.S.C. §552(b)(4).

For your ease in reviewing this petition, please refer to the table of contents which begins on page 3. If we can provide any additional information to assist your understanding or review of this document, please do not hesitate to contact us at 312-201-8310 or via email at Jeffrey@Antonelli-Law.com.

Thank you,

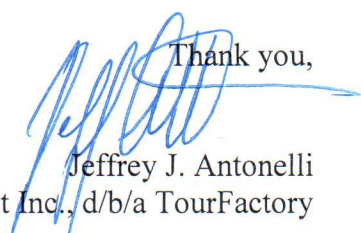

Jeffrey J. Antonelli
Attorney for Home Debut Inc., d/b/a TourFactory

Of Counsel
Mark C. Del Bianco
3929 Washington Street
Kensington, MD 20895
Tel: 301.933.7216
Cell: 301.602.5892
mark@markdelbianco.com

Of Counsel
Kate D. Fletcher
Airline Transport Pilot License
Type rated in:
CE-500 (Citation Jet)
SF-340 (Saab turbo prop)
DC-9 (turbo-jet)
B-737 (Boeing 737)
B-757 (Boeing 757)
B-767 (Boeing 767)
First Class Medical Certificate
Tel: 312.285.4359
kate@kdfletcherlaw.com

Table of Contents

I. Publishable Summary 5

II. Petitioner’s Contact Information 5

III. Proposed Operations..... 6

 A. The UA 6

 B. The Crew 8

 C. Flight Conditions 9

 D. Flight Operations 9

IV. Aircraft and Equivalent Level of Safety 9

V. Proposed Conditions of the Exemption 10

VI. Privacy 13

VII. Public Interest and Safety 13

VIII.Regulations from Which Exemption is Requested 15

 A. Appendix A: FARs as to which TourFactory wishes the same determination to be made as has been made previously..... 15

 B. Appendix B: TourFactory’s argument for exemption from 14 C.F.R. §61.113: Private pilot privileges and limitations: Pilot in command. 18

 1. The FAA and foreign regulators recognize that obtaining a manned aircraft pilot license is unnecessary for safe operation of a UA. 18

 2. The FAA has and has already exercised the authority to exempt petitioners from the airman certificate requirement. 20

Exhibit List

Exhibit 1: TourFactory UAS PolicySubmitted confidentially to the FAA
Exhibit 2: Phantom Pilot Training Guide..... Submitted separately due to upload restrictions
Exhibit 3: Phantom Flying Flowchart 23
Exhibit 4: Naza M V2 User Manual..... 24
Exhibit 5: Smart Flight Battery Safety Guidelines..... 57

Phantom 1 Exhibits

Exhibit 6: Phantom 1 Quick Start Guide..... Submitted separately due to upload restrictions
Exhibit 7: Phantom 1 Advanced Manual Submitted separately due to upload restrictions
Exhibit 8: Phantom 1 63
Exhibit 9: Phantom 1 Features 66
Exhibit 10: Phantom 1 Specifications 68

Phantom 2 Exhibits

Exhibit 11: Phantom 2 Quick Start Guide..... Submitted separately due to upload restrictions
Exhibit 12: Phantom 2 User Manual Submitted separately due to upload restrictions
Exhibit 13: Phantom 2 71
Exhibit 14: Phantom 2 Features 77
Exhibit 15: Phantom 2 Specifications 86

Phantom 2 Vision Exhibits

Exhibit 16: Phantom 2 Vision Quick Start Guide
..... Submitted separately due to upload restrictions
Exhibit 17: Phantom 2 Vision User Manual Submitted separately due to upload restrictions
Exhibit 18: Phantom 2 Vision 88
Exhibit 19: Phantom 2 Vision Features 92
Exhibit 20: Phantom 2 Vision Specifications 104

Phantom 2 Vision+ Exhibits

Exhibit 21: Phantom 2 Vision+ Quick Start Guide
..... Submitted separately due to upload restrictions
Exhibit 22: Phantom 2 Vision+ User Manual
..... Submitted separately due to upload restrictions
Exhibit 23: Phantom 2 Vision+ 107
Exhibit 24: Phantom 2 Vision+ Features 111
Exhibit 25: Phantom 2 Vision+ Specifications 120

Exhibit 1 has been submitted confidentially and is not available to the public.

Exhibits 2, 6-7, 11-12, 16-17, and 21-22 have been uploaded as separate documents due to file size constraints.

I. Publishable Summary

Pursuant to 14 C.F.R. § 11, the following summary is provided for publication in the Federal Register, should it be determined that publication is needed:

Petitioner seeks an exemption from the following rules:

14 C.F.R. 21(h); 14 C.F.R. 43.7; 14 C.F.R. 43.11; 14 C.F.R. 45.11; 14 C.F.R. 45.27; 14 C.F.R. 45.29; 14 CFR 61.23(a) and (c); 14 CFR 61.101(e)(4) and (5) 14 CFR 61.113(a); 14 CFR 61.315(a); 14 C.F.R. 91.7(a); 14 C.F.R. 91.9(b)(2); 14 C.F.R. 91.9(c); 14 C.F.R. 91.103(b)(2); 14 C.F.R. 91.105; 14 C.F.R. 91.109; 14 C.F.R. 91.113(b); 14 C.F.R. 91.119(c); 14 C.F.R. 91.121; 14 C.F.R. 91.151(a); 14 C.F.R. 91.203(a) and (b); 14 C.F.R. 215; 14 C.F.R. 91.403; 14 C.F.R. 91.405(a); 14 C.F.R. 91.407(a)(1); 14 C.F.R. 409(a)(1) and (a)(2); and 14 C.F.R. 91.417(a) and (b) to operate commercially a small unmanned aircraft system (UA) to operate commercially a small unmanned aircraft system (UA) (2.74 lbs. or less).

Approval of the exemption requested by petitioner will allow commercial operation of the DJI Phantom 1, Phantom 2, Phantom 2 Vision, and Phantom 2 Vision+ for real estate photography in Class G airspace nationwide, or as otherwise prescribed by an Air Traffic Organization (ATO) issued COA. The requested exemption should be granted because operation of small UAs, weighing between approximately 2.2 lbs. (1 kg.) and 2.74 lbs. (1.24 kg.) inclusive of battery and payload, conducted in the strict conditions outlined below, will provide an equivalent level of safety, while still allowing commercial operations. The lightweight aircraft covered by the exemption are far safer than conventional operations conducted with helicopters and fixed-wing aircraft weighing thousands of pounds and carrying highly flammable fuel, and operating in close proximity to the ground, trees, infrastructure, and people. The seven factors Congress directed the FAA to consider when approving Section 333 exemption petitions - size, weight, speed, operational capability, proximity to airports, proximity to populated areas, and operation within visual line of sight – each support the request. In particular, the aircraft are small, and will operate at slow speeds, and close to the ground in order to more safely and efficiently conduct inspections that would otherwise involve a risk of death to the inspectors. The substantial increase of safety and decrease of risk to human life, coupled with the low risk use of UAs to conduct these operations, weigh heavily in favor of granting the exemption.

II. Petitioner's Contact Information

Herb Dierks
CEO
Home Debut, Inc., d/b/a TourFactory
505 W Riverside Ave
Suite 300
Spokane, WA 99201

Counsel for Petitioner:
Antonelli Law

35 East Wacker Drive
 Suite 1875
 Chicago, IL 60601
 Tel: 312-201-8310
 Fax: 888-211-8624
 Email: jeffrey@antonelli-law.com

III. Proposed Operations

A. The UA

The requested exemption will permit petitioner to operate the DJI Phantom 1, Phantom 2, Phantom 2 Vision, and Phantom 2 Vision+. Please refer to Exhibits 2-25 for further information about each of the airframes and the Naza M V2 control system. The petition and the supporting documentation in those exhibits and Exhibit 1 are hereinafter referred to as the “operating documents.”

Each UA proposed under this exemption has the ability to hover and move in the vertical and horizontal planes simultaneously. Please refer to the following chart detailing the technical specifications of each of the UAs. This chart also lists the specific exhibits pertaining to each UA.

Airframe	Phantom 1	Phantom 2	Phantom 2 Vision	Phantom 2 Vision+
Control System	DJI Naza M V2 which includes the Main Controller (MC), Internal Measurement Unit (IMU) with a built-in internal sensor, barometric altimeter (which measures attitude and altitude), compass, GPS, and radio receiver (Rx).	DJI Naza M V2 which includes the Main Controller (MC), Internal Measurement Unit (IMU) with a built-in internal sensor, barometric altimeter (which measures attitude and altitude), compass, GPS, and radio receiver (Rx).	DJI Naza M V2 which includes the Main Controller (MC), Internal Measurement Unit (IMU) with a built-in internal sensor, barometric altimeter (which measures attitude and altitude), compass, GPS, and radio receiver (Rx).	DJI Naza M V2 which includes the Main Controller (MC), Internal Measurement Unit (IMU) with a built-in internal sensor, barometric altimeter (which measures attitude and altitude), compass, GPS, and radio receiver (Rx).
Maximum Speed	20 knots	30 knots	30 knots	30 knots
Weight, inclusive of battery and technical payload	2.2 lbs. (1 kg.)	2.2 lbs. (1 kg.)	2.56 lbs. (1.16 kg.)	2.74 lbs. (1.24 kg.)

Airframe	Phantom 1	Phantom 2	Phantom 2 Vision	Phantom 2 Vision+
Transmitter (Tx)	2.4 GHZ	2.4 GHZ	5.728 – 5.8 GHZ	5.728 GHZ – 5.85 GHZ
Receiver (Rx)	Internal in the control system	Internal in the control system	5.8 GHZ	5.8 GHZ
Motors	DJI 2212	DJI 2212 (old); DJI 2213 (new)	DJI 2212	DJI 2312 CCW
Propellers	4 x 9”	4 x 9”	4 x 9”	4 x 9”
Data Link			2.4 GHZ	2.4 GHZ
Video Link		DJI Lightbridge 2.4GHZ or AVL 58	Internal in the control system	Internal in the control system
Gimbal	Zenmuse	Zenmuse	Zenmuse	Zenmuse
Batteries	Lithium Polymer batteries with a capacity of 2200 mah	Lithium Polymer batteries with capacity of 5200 mah	Lithium Polymer batteries with capacity of 5200 mah	Lithium Polymer batteries with capacity of 5200 mah
OSD		iOSD mini or iOSD Mark II which allows live telemetry to be displayed to the visual observer, including the battery level and altitude	The OSD capabilities are built into the unit and the DJI vision app, giving the operator the ability to use a compatible mobile device or tablet as an FPV monitor allowing live telemetry to be displayed, including the battery level and altitude.	The OSD capabilities are built into the unit and the DJI vision app, giving the operator the ability to use a compatible mobile device or tablet as an FPV monitor allowing live telemetry to be displayed, including the battery level and altitude.

Airframe	Phantom 1	Phantom 2	Phantom 2 Vision	Phantom 2 Vision+
Automatic Return to Home	If Tx signal is lost for more than three seconds and the UA is under 65 ft. (20 m.) AGL, the UA will rise to 65 ft. AGL, travel horizontally to the pre-designated home spot, hover for 15 seconds, then land. If the UA is above 65 ft. AGL, travel horizontally to the pre-designated home spot, hover for 15 seconds, then land.	If Tx signal is lost for more than three seconds and the UA is under 65 ft. (20 m.) AGL, the UA will rise to 65 ft. AGL, travel horizontally to the pre-designated home spot, hover for 15 seconds, then land. If the UA is above 65 ft. AGL, travel horizontally to the pre-designated home spot, hover for 15 seconds, then land.	If Tx signal is lost for more than three seconds and the UA is under 65 ft. (20 m.) AGL, the UA will rise to 65 ft. AGL, travel horizontally to the pre-designated home spot, hover for 15 seconds, then land. If the UA is above 65 ft. AGL, travel horizontally to the pre-designated home spot, hover for 15 seconds, then land.	If Tx signal is lost for more than three seconds and the UA is under 65 ft. (20 m.) AGL, the UA will rise to 65 ft. AGL, travel horizontally to the pre-designated home spot, hover for 15 seconds, then land. If the UA is above 65 ft. AGL, travel horizontally to the pre-designated home spot, hover for 15 seconds, then land.
Corresponding Exhibits	4-10	4-5; 11-15	4-5; 16-20	4-5; 20-24
Previously approved Exemption Nos.	11301; 11318	11153; 11157; 11195; 11220; 11228; 11250; 11253; 11271; 11280; 11289; 11297; 11302; 11306; 11315; 11318	11267; 11273; 11296; 11310	11218; 11224; 11228; 11230; 11138; 11260; 11275; 11288; 11189; 11191; 11215; 11293; 11295; 11300; 11304; 11313

The specific conditions of the proposed exemption that relate to the characteristics of the UAs are numbers 1, 5, 19, 20, 21, and 30 in Section V below. Each has been adopted or imposed by the FAA in numerous previous grants of Section 333 exemption petitions.

B. The Crew

The crew will consist of a pilot in command (PIC) and a visual observer (VO). The PIC and VO will have been trained in operation of UA generally and received up-to-date information on the UA to be operated pursuant to this grant. The PIC will have completed, at a minimum, 20 hours of UA flight training with this specific UA prior to operations, and will be required to participate in annual training thereafter.

The specific conditions of the proposed exemption that relate to the training and

characteristics of the crew are numbers 6-10 in Section V below. Each has been adopted or imposed by the FAA in numerous previous grants of Section 333 exemption petitions.

C. Flight Conditions

The UA will be used to take real estate photography nationwide. It will be flown in Class G airspace under 200 feet above ground level (“AGL”) and under controlled conditions over property that is restricted as stated in Section 5 of Exhibit 1. Petitioner will work with the local FSDO when planning operations. Petitioner will only operate its UA in visual meteorological conditions (VMC). The UA will at all times be no less than 500 feet below and no less than 2,000 feet horizontally from a cloud, and petitioner will not conduct operations unless visibility is at least 3 statute miles from the PIC. The flight crew will always make a safety assessment of the risk of every operation, and will only operate when it is determined that no hazards are present.

Please refer to Exhibit 1 Section 5 for more information regarding flight conditions.

The specific conditions of the proposed exemption that relate to the flight conditions in which the UA will be operated are numbers 27, 28, 29, and 34 in Section V below. Each has been adopted or imposed by the FAA in numerous previous grants of Section 333 exemption petitions.

D. Flight Operations

The purpose of every UA flight will be to safely, accurately, and efficiently take aerial photography for real estate.

Every UA flight will use at minimum a two person flight crew: a PIC and a VO. The standard operational procedures that they will follow are set out in Exhibit 1. Please refer to the following sections for information pertaining to operations:

- Section 5: Pre-Flight Safety Procedures
- Section 6: UAS Routine Inspection and Maintenance
- Section 7: In-Flight Safety Operations
- Section 8: Visual Observer Responsibilities
- Section 9: Emergencies

The specific conditions of the proposed exemption that relate to flight operations are numbers 2, 3, 11-18, 22-24, 26, 32, 33, 35, and 36 in Section V below. Each has been accepted or imposed by the FAA in numerous previous grants of Section 333 exemption petitions.

IV. Aircraft and Equivalent Level of Safety

Petitioner proposes that the exemption apply to UAs that have the characteristics and that operate with the limitations proposed herein. These limitations provide for a level of safety at least equivalent to or higher than manned aircraft operations under the current regulatory structure. Section V below identifies the limitations and conditions to which petitioner agrees to be bound when conducting commercial operations under a grant of this petition. Appendix A contains a matrix connecting (i) the specific proposed condition with (ii) the FAR provision for which it provides an equivalent level of safety and (iii) one or more recent Section 333

exemption grants in which the FAA recognized this equivalent level of safety.

Approval of the commercial operations outlined in this petition presents no national security issue. Petitioner is willing to require its PICs to undergo a background check, including the proposed Transportation Security Administration Vetting process, to ensure that no national security threat is present. Operation and Certification of Small Unmanned Aircraft, 80 Fed. Reg. 9543 at 9572 (proposed Feb. 23, 2015 (to be codified at 14 C.F.R. Parts 21, 43, 45, et al.)).

V. Proposed Conditions of the Exemption

1. The UAs will weigh between 2.2 lbs. (1 kg) and 2.74 lbs. (1.24 kg.).
2. UA operations under this exemption will be limited to conducting operations for the purpose of commercial real estate photography.
3. Flights will be operated within line of sight of the PIC and VO.
4. Flights will be operated at an altitude of no more than 200 feet AGL, as indicated by the procedures specified in the operating documents. All altitudes reported to ATC must be in feet AGL.
5. The UA will not be flown at an indicated airspeed exceeding 30 knots.
6. Minimum flight crew for each operation will consist of the UA pilot in command (PIC) and a visual observer (VO).
7. The PIC will have, at minimum, 20 hours of training on the UA to be operated under this grant before accepting commercial operations.
8. The petitioner will not permit any PIC to operate unless the PIC meets its qualification criteria and demonstrates the ability to safely operate the UA in a manner consistent with how the UA will be operated under this exemption, including evasive and emergency maneuvers and maintaining appropriate distances from persons, vessels, vehicles and structures. PIC qualification flight hours and currency will be logged in a manner consistent with 14 CFR § 61.51(b). A record of the PIC training will be documented and made available upon request by the Administrator. Training operations will only be conducted during dedicated training sessions. During training, proficiency, and experience-building flights, all persons not essential for flight operations will be considered nonparticipants, and the PIC will operate the UA with appropriate distance from nonparticipants in accordance with 14 CFR § 91.119.
9. The VO will not perform any other duties beyond assisting the PIC with seeing and avoiding other air traffic and other ground based obstacles/obstructions, and will not be permitted to operate the camera or other instruments.
10. The PIC will be designated before the flight and will not be allowed to transfer his or her designation for the duration of the flight. The PIC will ensure that the VO can perform the functions prescribed in these conditions and the operating documents.

11. A briefing will be conducted in regard to the planned UA operations prior to each day's activities. It will be mandatory that all personnel who will be performing duties in connection with the operations be present for this briefing.
12. Prior to each flight, the PIC will inspect the UA, including the Ground Control Station, to ensure it is in a condition for safe flight. If the inspection reveals a condition that affects the safe operation of the UA, the PIC will not operate the UA until the necessary maintenance has been performed and the UA is found to be in a condition for safe flight. All maintenance and alterations will be properly documented in the aircraft records.
13. Petitioner will conduct a functional flight test on any UA that has undergone maintenance or alterations that affect the UA operation or flight characteristics, e.g. replacement of a flight critical component. The PIC who conducts the functional test flight will make an entry in the aircraft records.
14. The petitioner will carry out its maintenance, inspections, and record keeping requirements, in accordance with the UA manufacturer's aircraft/component, maintenance, overhaul, replacement, inspection, and life limit requirements set forth in the operating documents. Maintenance, inspection, alterations, and status of replacement/overhaul component parts will be noted in the aircraft records, including total time in service, description of work accomplished, and the signature of the authorized person returning the UA to service. The authorized person will make an entry in the aircraft record of the corrective action taken against discrepancies discovered between inspections.
15. The UA will be operated within visual line of sight (VLOS) of the PIC and VO at all times. This requires the PIC to be able to use human vision unaided by any device other than corrective lenses. PIC and VO will at all times be able to communicate verbally. They will not be permitted to use electronic messaging or texting to communicate during flight operations.
16. The PIC will not begin a flight unless (considering wind and forecast weather conditions) there is enough power to fly at normal cruising speed to the intended landing point and land the UA with 25% battery power remaining.
17. Actual total flight time for each operational flight will result in no less than a 25% battery reserve.
18. The UA will have the capability to abort a flight in case of unexpected obstacles or emergencies.
19. The UA will be programmed so that if it loses communications or loses its GPS signal, it will return to a pre-determined location within the planned operating area and land or be recovered in accordance with the operating documents.
20. If the UA and its radio control link disconnect during flight, the system's failsafe protection will be triggered and the multirotor will return to home and land automatically, rather than flying off uncontrollably or landing at an unknown location.
21. The operating documents required under 14 CFR §§ 91.9 and 91.203 will be maintained and

available to the PIC at the Ground Control Station of the UA any time the UA is operating. These documents will be made available to the Administrator or any law enforcement official upon request. If a discrepancy exists between the conditions and limitations in the exemption grant and the procedures outlined in the operating documents, the grant conditions and limitations will take precedence and will be followed. Otherwise, the petitioner will follow the procedures outlined in its operating documents. If it updates or revises its operating documents, it will present updated and revised documents to the Administrator upon request. If the petitioner determines that any update or revision would affect the basis upon which the FAA granted the exemption, then the Petitioner will petition for an amendment to the grant of exemption.

22. Petitioner will obtain written and/or oral permission from the landowners/authorized agents of the landowners over which flights will be conducted.
23. Petitioner will obtain all required permissions and permits from territorial, state, county or city jurisdictions, including local law enforcement, fire, or other appropriate governmental agencies.
24. UA operations will not be conducted during night, as defined in 14 CFR § 1.1. All operations will be conducted under visual meteorological conditions (VMC). Flights will not be conducted under special visual flight rules (SVFR).
25. The petitioner will obtain an Air Traffic Organization (ATO) issued Certificate of Waiver or Authorization (COA) prior to conducting any operations under the grant of exemption. Petitioner will request a Notice to Airman (NOTAM) not more than 72 hours in advance, but not less than 48 hours prior to the operation. All operations will be conducted in accordance with airspace requirements in the ATO issued COA, including class of airspace, and altitude level.
26. The UA will not be operated within 5 nautical miles of an airport reference point as denoted on a current FAA-published aeronautical chart unless a letter of agreement with that airport's management has been obtained, and the operation is conducted in accordance with a NOTAM as required by the operator's COA. Any letter of agreement with the airport management will be made available to the Administrator upon request.
27. The UA will not be operated less than 500 feet below, or less than 2,000 feet horizontally from, a cloud or when visibility is less than 3 statute miles from the PIC.
28. All operations shall be conducted in Class G airspace or as otherwise prescribed in an ATO issued COA.
29. All aircraft operated in accordance with this exemption will be identified by serial number, registered in accordance with 14 CFR part 47, and have identification (N-Number) markings in accordance with 14 CFR part 45, Subpart C. Markings will be as large as practicable.
30. Before conducting operations, petitioner will ensure that the radio frequency spectrum used for operation and control of the UA complies with the Federal Communications Commission (FCC) or other appropriate government oversight agency requirements.

31. The UA will remain clear and yield the right of way to all manned aviation operations and activities at all times.
32. The UA will not be operated by the PIC from any moving device or vehicle.
33. Petitioner will conduct all flight operations at least 500 feet from all nonparticipating persons, vessels, vehicles, and structures unless one of the following three conditions is met:
 - a. Barriers or structures are present that sufficiently protect nonparticipating persons from the UA and/or debris in the event of an accident. The petitioner will ensure that nonparticipating persons remain under such protection. If a situation arises where nonparticipating persons leave such protection and are within 500 feet of the UA, the PIC will ensure that flight operations cease immediately.
 - b. The aircraft is operated near vessels, vehicles or structures where the owner/controller of such vessels, vehicles or structures has granted permission and the PIC has made a safety assessment of the risk of operating closer to those objects and determined that it does not present an undue hazard.
 - c. Operations nearer to the PIC, VO, operator trainees or essential persons do not present an undue hazard to those persons per § 91.119(a).
34. Petitioner will report any incident, accident, or flight operation that transgresses the lateral or vertical boundaries of the operational area as defined by the applicable COA to the FAA's UA Integration Office (AFS-80) within 24 hours. Petitioner will report accidents to the National Transportation Safety Board (NTSB) per instructions contained on the NTSB Web site: www.nts.gov.

VI. Privacy

There is little concern that the proposed flights will cause invasions of privacy because all flights will occur over private property with the landowner's/authorized agent's permission. When the UA is being flown, the onboard cameras will be focused on the specific property and thus turned so as to be facing away from any occupied structures that may be in the area to minimize inadvertent video or still images of uninvolved persons. Please refer to Exhibit 1 Section 10: Privacy for more information regarding petitioner's privacy policy.

VII. Public Interest and Safety

The planned UA use will increase ground safety for real estate photography. The enhanced safety and reduced environmental impact achieved using a UA with the specifications described by the petitioner and carrying no passengers or crew, rather than a manned aircraft of significantly greater proportions, carrying crew in addition to flammable fuel, gives the FAA good cause to find that the UA operation enabled by this exemption is in the public interest.

Satisfaction of the criteria provided in Section 333 of the Reform Act of 2012 – size, weight, speed, operating capabilities, proximity to airports and populated areas and operation within visual line of sight and national security – provide more than adequate justification for the grant of the requested exemption allowing commercial operation of petitioner's UA in the

purposes of commercial real estate photography, pursuant to TourFactory’s rules of operation. The FAA has previously approved members of the DJI Phantom family for real estate photography in Exemption Nos. 11191, 11195, 11271, 11295, 11300, and 11318.

The small weight of the Phantom UA family, ranging from 2.2 lbs. to 2.74 lbs. (1 kg. to 1.24 kg.), is less than the size envisioned in Section 334(c)(2)(C) of the FAA Modernization and Reform Act of 2012, which allows government agencies “to operate unmanned aircraft weighing 4.4 pounds or less, if operated –

- i. within the line of sight of the operator;
- ii. less than 400 feet above the ground;
- iii. during daylight conditions;
- iv. within Class G airspace; and
- v. outside of 5 statute miles from any airport, heliport, seaplane base, spaceport, or other location with aviation activities.”

Congress’s determination that government agencies should be allowed to operate such aircraft in these situations, with no further restrictions on location, population density, or pilot experience and training, indicates that Congress did not believe that aircraft of this size and weight warranted additional attention.

VIII. Regulations from Which Exemption is Requested

A. Appendix A: FARs as to which TourFactory wishes the same determination to be made as has been made previously.

FAR Provision	Applicable condition(s) in Section 5 of petition	FAA Exemption Decision
21(h)	1, 2, 3, 4, 5, 16, 25, 28, 29, 33, 34	Nos. 11062, 11063, 11064, 11065, 11066, 11067, 11080, 11109, 11111, 11110, 11114, 11136, 11138, 11150, 11153, 11156, 11157, 11166, 11167, 11170, 11171, 11172, 11174, 11176, 11177, 11178, 11184, 11185, 11188, 11189, 11191, 11192, 11193, 11195
43.7	13, 14	No. 11208
43.11	12	No. 11208
45.11	30	No. 11208
45.27	30	No. 11188
45.29	30	Nos. 11136, 11157, 11170, 11185, 11193
61.23(a) and (c), 61.101(e)(4) and (5), 61.113(a), 61.315(a),	7	See Appendix B for argument regarding why petitioner should be exempted from the private pilot license requirement
91.7(a)	12	Nos. 11062, 11063, 11064, 11065, 11066, 11067, 11080, 11109, 11110, 11136, 11138, 11150, 11153, 11156, 11157, 11158, 11160, 11161, 11166, 11167, 11170, 11171, 11172, 11174, 11177, 11178, 11184, 11185, 11188, 11189, 11191, 11192, 11193, 11195, 11204
91.9(b)(2)	22	Nos. 11062, 11063, 11064, 11065, 11066, 11067, 11080, 11109, 11110, 11111, 11112, 11114, 11136, 11138, 11150, 11153, 11156, 11157, 11062, 11063, 11064, 11065, 11066, 11067, 11080, 11109, 11110, 11111, 11112, 11114, 11136, 11138, 11150, 11153, 11156, 11157, 11174, 11177, 11178, 11184, 11185, 11189, 11192, 11193, 11195
91.9(c)	30	Nos. 11136, 11170, 11171, 11174, 11185
91.103(b)(2)	3, 9, 16, 17, 18, 19, 20, 28	No. 11062, 11063, 11064, 11065, 11066, 11067, 11080, 11109, 11138, 11150, 11153, 11156, 11158, 11160, 11161, 11166, 11167, 11171, 11172, 11176, 11177, 11178, 11184, 11185, 11188, 11188, 11189, 11191, 11192, 11193, 11195, 11204
91.105	6	No. 11185

FAR Provision	Applicable condition(s) in Section 5 of petition	FAA Exemption Decision
91.109	7, 8	Nos. 11062, 11063, 11064, 11065, 11066, 11067, 11080, 11109, 11110, 11112, 11136, 11138, 11150, 11153, 11156, 11157, 11166, 11167, 11170, 11171, 11174, 11177, 11184, 11185, 11189, 11191, 11192, 11193, 11194, 11195, 11206, 11208
91.113(b)	3, 32	No. 11238
91.119(c)	4, 33	Nos. 11162, 11163, 11164, 11165, 11166, 111080, 111109, 11110, 11111, 11112, 11114, 11136, 11138, 11150, 11153, 11156, 11160 11161, 11166, 11167, 11170, 11171, 11172, 11174, 11176, 11178, 11185, 11188, 11189, 11190, 11193
91.121	4	Nos. 11162, 11163, 11164, 11165, 11166, 111080, 111109, 11136, 11138, 11150, 11153, 11156, 11160 11161, 11166, 11167, 11170, 11171, 11174, 11176, 11178, 11185, 11188, 11189, 11190, 11193
91.151(a)	17, 18	Nos. 11110, 11153, 11156, 11161; 111109, 11110, 11112, 11136, 11138, 11150, 11153, 11156, 11160 11161, 11166, 11167, 11170, 11171, 11172, 11174, 11176, 11178, 11185, 11188, 11189, 11190, 11193
91.203 (a) and (b)	22	Nos. 11062, 11063, 11064, 11065, 11066, 11067, 11080, 11109, 11110, 11111, 11112, 11114, 11136, 11138, 11150, 11153, 11156, 11157, 11170, 11171, 11172, 11174, 11176, 11177, 11178, 11184, 11185, 11188, 11188, 11189, 11191, 11192, 11193, 11195
91.215	26, 27	No. 11185, 11195
91.403	12, 13, 14	No. 11185
91.405(a)	12, 13, 14	Nos. 11062, 11063, 11064, 11065, 11066, 11067, 11080, 11109, 11110, 11111, 11112, 11114, 11136, 11138, 11150, 11153, 11156, 11157, 11158, 11160, 11161, 11166, 11167, 11170, 11171, 11172, 11174, 11176, 11177, 11178, 11184, 11185, 11188, 11188, 11189, 11191, 11192, 11193, 11195, 11204
91.407(a)(1)	14	Nos. 11062, 11063, 11064, 11065, 11066, 11067, 11080, 11109, 11110, 11111, 11112, 11114, 11136, 11138, 11150, 11153, 11156, 11157, 11158, 11160, 11161, 11166, 11167, 11170, 11171, 11172, 11174, 11176, 11177, 11178, 11184, 11185, 11188, 11188, 11189, 11191, 11192, 11193, 11195, 11204

FAR Provision	Applicable condition(s) in Section 5 of petition	FAA Exemption Decision
91.409(a)(1)	12, 13, 14	Nos. 11062, 11063, 11064, 11065, 11066, 11067, 11080, 11109, 11110, 11111, 11112, 11114, 11136, 11138, 11150, 11153, 11156, 11157, 11158, 11160, 11161, 11166, 11167, 11170, 11171, 11172, 11174, 11176, 11177, 11178, 11184, 11185, 11188, 11188, 11189, 11191, 11192, 11193, 11195, 11204
91.409(a)(2)	12, 13, 14	Nos. 11062, 11063, 11064, 11065, 11066, 11067, 11080, 11109, 11110, 11111, 11112, 11114, 11136, 11138, 11150, 11153, 11156, 11157, 11158, 11160, 11161, 11166, 11167, 11170, 11171, 11172, 11174, 11176, 11177, 11178, 11184, 11185, 11188, 11188, 11189, 11191, 11192, 11193, 11195, 11204
91.417(a)	12, 13, 14	Nos. 11062, 11063, 11064, 11065, 11066, 11067, 11080, 11109, 11110, 11111, 11112, 11114, 11136, 11138, 11150, 11153, 11156, 11157, 11158, 11160, 11161, 11166, 11167, 11170, 11171, 11172, 11174, 11176, 11177, 11178, 11184, 11185, 11188, 11188, 11189, 11191, 11192, 11193, 11195, 11204
91.417(b)	12, 13, 14	Nos. 11062, 11063, 11064, 11065, 11066, 11067, 11080, 11109, 11110, 11111, 11112, 11114, 11136, 11138, 11150, 11153, 11156, 11157, 11158, 11160, 11161, 11166, 11167, 11170, 11171, 11172, 11174, 11176, 11177, 11178, 11184, 11185, 11188, 11188, 11189, 11191, 11192, 11193, 11195, 11204

B. Appendix B: TourFactory’s argument for exemption from 14 CFR §§ 61.23(a) and (c), 61.101(e)(4) and (5), 61.113(a), 61.315(a).

TourFactory requests an exemption from 14 CFR §§ 61.23(a) and (c), 61.101(e)(4) and (5), 61.113(a), 61.315(a), so that the PIC of the UA will not be required to possess any pilot license (sports, recreational, private or commercial). As the FAA and numerous other national airspace regulators have recognized, UA operations conducted by persons who do not hold a pilot’s license can still achieve the equivalent level of safety of current operations by manned aircraft with pilots holding any level of pilot’s license.

Although it recognizes that a pilot’s license is unnecessary for safe UA operation, the FAA has to date declined to allow grant exemptions under Section 333 that would permit individuals who possess any pilot license (sports, recreational, private or commercial) to conduct commercial UA operations. It has specified two reasons for declining to do so. First, it has stated that it does not possess the authority under Section 333 to exempt individuals from the requirement under 49 U.S.C. §44711 to hold an airman certificate authorizing the airman to serve in the capacity for which the certificate was issued. Exemption No. 11110 at 14. Second, the FAA has concluded that the Department of Homeland Security (DHS) security screening required of all certified airmen meets the statutory requirement in Section 333 that operations not pose a threat to national security. Exemption No. 11110 at 15.

TourFactory respectfully requests that the FAA reconsider its position. There is no dispute that it is unnecessary for an operator of a UA to go through the rigorous process of becoming a certified pilot in order to safely operate a UA. In addition, the FAA does have the authority to exempt UA operators from the requirement in 49 U.S.C. §44711 to hold an airman certificate for “serv[ing] in the capacity for which the certificate was issued.” Indeed, it has exercised that authority repeatedly in the Section 333 process. Finally, the FAA’s security concerns can be addressed by a variety of methods involving operator background checks to be conducted by government agencies.

1. The FAA and foreign regulators recognize that obtaining a manned aircraft pilot license is unnecessary for safe operation of a UA.

The FAA, like the other national airspace regulators that have considered the issue, has concluded that UA operations conducted by persons who do not hold a pilot’s license can still achieve the equivalent level of safety of current operations by manned aircraft with pilots holding any level of pilot’s license. In its recent UAS NPRM, the FAA stated:

“While these airman certification requirements are necessary for manned aircraft operations, they impose an unnecessary burden for many small UAS operations. This is because a person typically obtains a private or commercial pilot certificate by learning how to operate a manned aircraft. Much of that knowledge would not be applicable to small UAS operations because a small UAS is operated differently than manned aircraft. In addition, the knowledge currently necessary to obtain a private or commercial pilot certificate would not equip the certificate holder with the tools necessary to safely operate a small UAS... Thus, requiring persons wishing to operate a small UAS to obtain a private or commercial pilot certificate imposes the cost of certification on those persons, but does not result in a significant safety benefit because the process of obtaining the certificate does

not equip those persons with the tools necessary to mitigate the public risk posed by small UAS operations.” Operation and Certification of Small Unmanned Aircraft, 80 Fed. Reg. 9543 at 9550 (proposed Feb. 23, 2015 (to be codified at 14 C.F.R. Parts 21, 43, 45, et al.).

The FAA’s conclusion that manned aircraft flying experience is unnecessary for the operation of a UA is supported by research by the FAA and the Army Research Laboratory. They demonstrate that UAs, even those much larger than the UAs proposed by TourFactory, can be safely flown by non-certificated pilots with a small amount of training. For example, one Army Research Laboratory study concluded:

“[T]he specific motor skills needed to control the radio-controlled UAV would have to be learned by aviators independently of the motor skills learned in flying an aircraft. In particular, the somatic and visual cues that pilots use during aircraft landings would not be useful (and perhaps even counter-productive) for the different skill sets and perceptual viewpoint necessary for radio-controlled landings.”¹

Additional research reports lend further support for the exclusion requested. For example, a report sponsored by the FAA concluded that “We know that certain systems, like the U.S. Army Hunter and Shadow systems, are successfully flown by pilots with no manned aircraft experience.”²

In addition, foreign government airspace regulators that have examined the issue have consistently recognized that the skills required to fly a manned aircraft are irrelevant to operating a UA. For that reason, they have concluded that UA operators do not need to have a private or commercial pilot’s license. Canada, for example, does not require a pilot’s license to operate a UA. Transport Canada requires training of UA operators, but that training is limited to pilot ground school and flight operation training on UAs, not manned aircraft.³ Moreover, Canada allows this training to be “provided by other pilots, manufacturers, [UA] flight training organizations or . . . self taught.”⁴

¹ Michael J. Barnes, Beverly G. Knapp, Barry W. Tillman, Brett A. Walters & Darlene Veliki, *Crew systems analysis of unmanned aerial vehicle (UAV) future job and tasking environments*, Technical Report ARL-TR-2081, Aberdeen Proving Ground, MD: Army Research Laboratory, page 12 (2000), available at <http://www.dtic.mil/dtic/tr/fulltext/u2/a374230.pdf>.

² Kevin W. Williams, *Unmanned Aircraft Pilot Medical Certification Requirements*, Report DOT/FAA/AM-07/3, FAA Civil Aerospace Medical Institute, page 2, (2007), available at <http://fas.org/irp/program/collect/ua-pilot.pdf>. While the authors speculated that UA use in populated areas may change this assessment, indicating further research was needed to address this concern, this concern is inapplicable as TourFactory’s flights will not be in congested areas. See also Jason S. McCarley & Christopher D. Wickens, *Human Factors Implications of UAVs in the National Airspace*, Institute of Aviation, Aviation Human Factors Division, University of Illinois at Urbana-Champaign, 13 (2004), available at <http://www.tc.faa.gov/logistics/grants/pdf/2004/04-G-032.pdf>.

³ See Civil Aviation, Standards, Transport Canada, Advisory Circular: Guidance Material for Operating Unmanned Air Vehicle Systems under an Exemption at 14 and 18-22, (Nov. 27, 2014) available at <http://www.tc.gc.ca/media/documents/ca-opssvs/ac-600-004.pdf>.

⁴ *Id.* at 14.

Similarly, the United Kingdom’s Civil Aviation Authority (CAA) recognized that determining “Remote Pilot qualification requirements on the same basis as manned aircraft may yield requirements that are too inflexible, too onerous and inappropriate for UAS operations.”⁵ As a result, the CAA only requires UA operators to demonstrate UA operator competence.⁶ While there are a variety of ways to demonstrate competence, the most common is to complete a course that will lead to a ground exam and flight test. Australia, too, requires only passage of a UA-specific ground school program in lieu of a manned airman certificate.⁷ Finally, more than a dozen countries, including Germany, Italy, France, Spain and the Netherlands, have adopted the National UAS Certificate for Small Unmanned Aircraft (BNUC-S) Standard for UA pilot certification.⁸ This standard results in a type-specific UA certificate and does not require the operator to have a pilot’s license. The process involves taking a short ground school course, passing a ground school test and then passing a practical test on commercial operation of the specific UA per the UA manufacturer’s operations manual.

All of this experience and evidence indicates that the proposed exemption will provide a greater level of safety than operations under 14 C.F.R. §61.113. In this instance, the PICs will have gone through training as described above in Section III B. This training and education is focused on UAs generally, and in particular on the aircraft to be operated, rather than taking additional time and risk to train on a manned aircraft, weighing several thousand pounds and carrying highly flammable fuel.

The FAA has concluded in the NPRM that such UA-specific training is more than sufficient to provide an equivalent level of safety for UA operations. Sometime in the next 18-24 months, that position will be enshrined in a valid regulation. However, in the meantime, the FAA claims it lacks the authority to relax the requirement to possess a pilot certificate. As we show in the next section, that position is both incorrect and contradicted by the FAA’s recent decisions.

2. The FAA does have, and has already, exercised the authority to exempt petitioners from the airman certificate requirement.

The FAA claims that it lacks authority to exempt UA operators from the requirement of 49 U.S. §44711 to hold an airman certificate authorizing the airman “to serve in the capacity for which the certificate was issued.” See, e.g., Exemption No. 11110 at 14. This claim is inconsistent with both (i) the statutory language of that section and Section 333, and (ii) numerous recent FAA decisions.

The operative part of 49 USC §44711 provides that a “person may not . . . serve in any

⁵ Civil Aviation Authority, Safety Regulation Group, Unmanned Aircraft System Operations in UK Airspace – Guidance, Section 2, Chapter 5, Page 2 (Aug. 10, 2012), *available at* <https://www.caa.co.uk/docs/33/CAP722.pdf>.

⁶ Civil Aviation Authority, Unmanned Aircraft and Aircraft Systems, *available at* <http://www.caa.co.uk/default.aspx?catid=1995&pagetype=90>

⁷ Australian Government Civil Aviation Safety Authority, *available at* http://www.casa.gov.au/scripts/nc.dll?WCMS:STANDARD::pc=PC_100374.

⁸ See EuroUSC International, “Pilot Qualification,” *available at* <http://eurousc.com/services/pilot-qualifications/>.

capacity as an airman with respect to a civil aircraft, . . . used, or intended for use, in air commerce — (A) without an airman certificate authorizing the airman to serve in the capacity for which the certificate was issued . . . “ If the FAA’s interpretation were correct, this language would require that any person wishing to operate a UA for commercial operations have an airman certificate authorizing the person to serve as an airman in commercial operations.

However, in all of its recent grants of Section 333 petitions, the FAA has – without explicitly acknowledging the fact - exempted commercial UA operators from the §44711(A) requirement that they hold an airman certificate authorizing them “to serve in the capacity for which the certificate was issued.” It has done so by allowing them to operate UA so long as they hold a private pilot’s or sport pilot’s authorization, even though such a certificate does not permit commercial operations. Exemption No. 11062 at 15-18; Exemption No. 11110 at 14-16; Exemption No. 11191 at 3-5; and Exemption No. 11229 at 3 and 8.

The FAA argues that it cannot exempt petitioners from the requirements of §44711 because, while the specific language of Section 333 grants it limited statutory flexibility relative to 49 U.S.C. §44704 for the purposes of airworthiness certification, Section 333 does not provide flexibility relative to §44711 and other sections of Title 49. Exemption No. 11110 at 14. This argument ignores the plain language of Section 333. The relevant language of Section 333 is:

(a) IN GENERAL.—Notwithstanding any other requirement of this subtitle, and not later than 180 days after the date of enactment of this Act, the Secretary of Transportation shall determine if certain unmanned aircraft systems may operate safely in the national airspace system before completion of the plan and rulemaking required by section 332 of this Act or the guidance required by section 334 of this Act.

(b) ASSESSMENT OF UNMANNED AIRCRAFT SYSTEMS.—In making the determination under subsection (a), the Secretary shall determine, at a minimum—

(1) which types of unmanned aircraft systems, if any, as a result of their size, weight, speed, operational capability, proximity to airports and populated areas, and operation within visual line of sight do not create a hazard to users of the national airspace system or the public or pose a threat to national security; and

(2) whether a certificate of waiver, certificate of authorization, or airworthiness certification under section 44704 of title 49, United States Code, is required for the operation of unmanned aircraft systems identified under paragraph (1).

(c) REQUIREMENTS FOR SAFE OPERATION.—If the Secretary determines under this section that certain unmanned aircraft systems may operate safely in the national airspace system, the Secretary shall establish requirements for the safe operation of such aircraft systems in the national airspace system.

The language of Section 333(b) is permissive: it requires that the Secretary “determine, at a minimum . . . whether a certificate of waiver, certificate of authorization, or airworthiness certification under section 44704 of title 49, United States Code, is required for the operation of unmanned aircraft systems identified under paragraph (1).” Nothing in (b) precludes the

Secretary from determining whether or not a pilot's license is required for operation of a UA identified under paragraph (b)(1).

Indeed, the FAA has implicitly conceded the point by granting exemptions from the requirement that commercial UA operators hold a commercial pilot certificate. From an analytical standpoint, there is no difference between granting an exemption from the commercial pilot's license requirement and granting an exemption from the private or sport pilot's license requirement. Both are clearly exemptions from a specific statutory requirement in 49 U.S.C. §44711. If the FAA has the statutory authority under Section 333(b) to do the former, it has the same authority to do the latter.⁹

⁹ The FAA has not specifically identified the statutory provision that underpins its authority to grant the exemptions from the commercial pilot's license requirement. Whether the statutory basis is Section 333 or some other provision makes no difference. If there is a basis for a partial exemption from in 49 U.S.C. § 44711, that basis also justifies an exemption from the entire provision.

PHANTOM Flying Flowchart V1.0 (Simplified Version)

This flowchart is aiming at help you to get familiar with the flying procedures of PHANTOM, please read the Manual carefully to get the operation details. Its corresponding Firmware Version is V3.0.

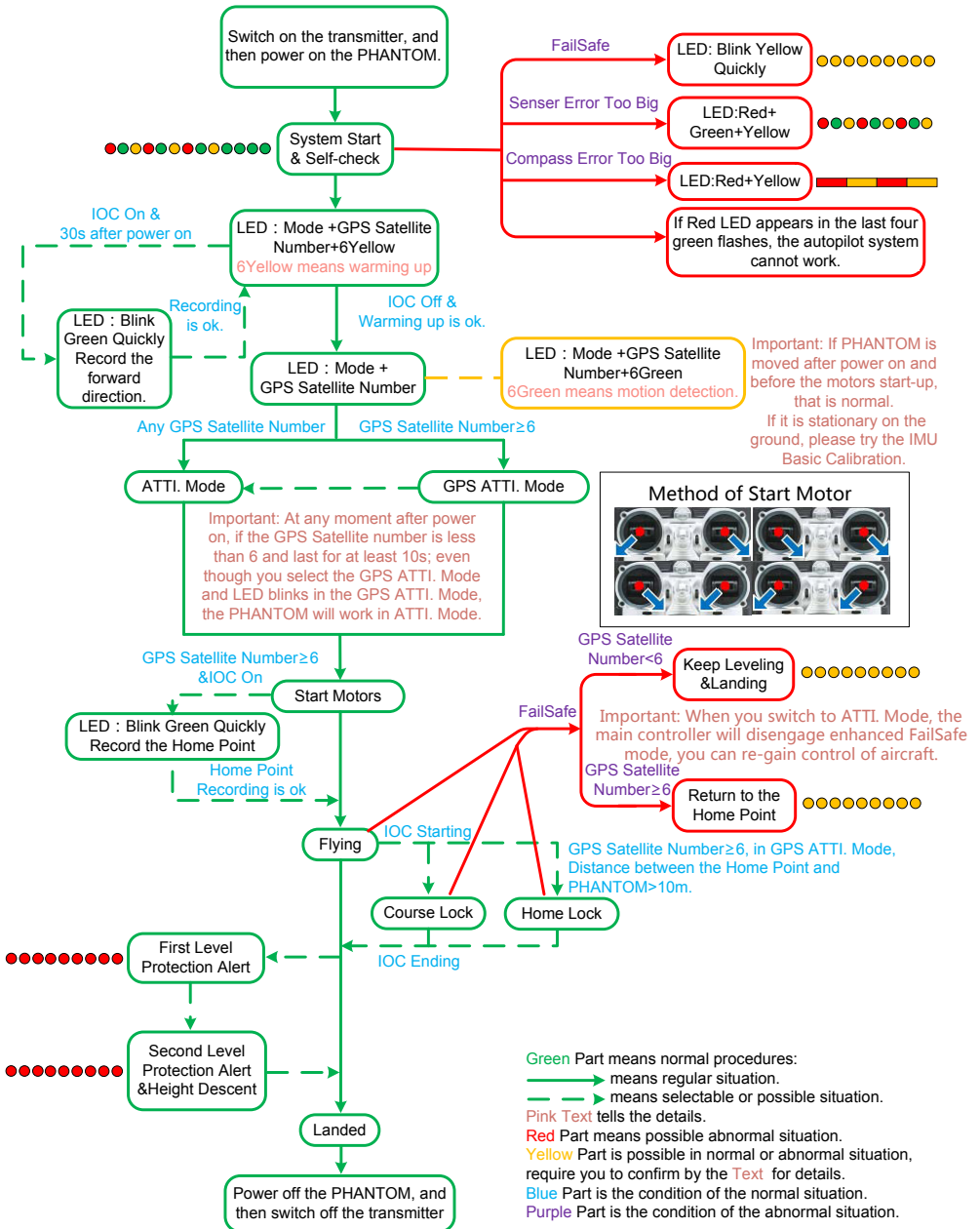

Naza - M V2

Quick Start Guide v1.26

2014.05.12 Revision

For Firmware Version V4.02 or above

& Assistant Software Version V2.20 or above

Thank you for purchasing this DJI product. Please strictly follow these steps to mount and connect this system on your aircraft, as well as to install the Assistant Software on your computer.

Please regularly check the web page of corresponding product* at our website www.dji.com, which is updated regularly. Product information, technical updates and manual corrections will be available on this web page. Due to unforeseen changes or product upgrades, the information contained in this manual is subject to change without notice.

* **Important:** Naza-M, Naza-M V2 and PHANTOM control system are different in hardware parts, but their configurations and functions are the same when using the same Assistant Software and Firmware Version, so they use the same Guide. Unless stated, the following instruction is basic on Naza-M V2. If you use the Naza-M, please make sure to read the "Instruction of V1 (also known as Naza-M)" section; if you use the PHANTOM, download the other corresponding manuals on the PHANTOM web page.

This manual is only for basic assembly and configuration; you can obtain more details and advanced instructions when using the assistant software. To assure you have the latest information, please visit our website and download the latest manual and current software version.

If you have any problem that you cannot solve during usage, please contact your authorized dealer.

Index

INDEX	2
INSTRUCTION	3
DISCLAIMER & WARNING	3
TRADEMARK.....	4
CERTIFICATIONS.....	4
SYMBOL INSTRUCTION.....	4
ASSEMBLY & CONNECTION	5
STEP1 PORT DESCRIPTION.....	5
STEP2 ASSEMBLY & CONNECTION	6
ASSISTANT SOFTWARE INSTALLATION AND CONFIGURATION	7
STEP1 SOFTWARE AND DRIVER INSTALLATION ON A PC.....	7
STEP2 CONFIGURATION BY ASSISTANT SOFTWARE ON A PC.....	8
BASIC FLYING	10
CONTROL MODE KNOWLEDGE	10
START & STOP MOTOR KNOWLEDGE.....	10
STEP1 COMPASS CALIBRATION	12
STEP2 ASSEMBLY CHECKING LIST.....	13
STEP3 BEFORE FLIGHT.....	13
STEP4 FLYING TEST.....	14
ADVANCED FUNCTIONS	16
A1 FAILSAFE	16
A2 LOW-VOLTAGE ALERT	17
A3 INTELLIGENT ORIENTATION CONTROL (IOC) FLIGHT (WITH GPS MODULE)	18
A4 RECEIVER ADVANCED PROTECTION FUNCTION	21
A5 FLIGHT LIMITS.....	22
APPENDIX	23
SPECIFICATIONS	23
MC/PMU FIRMWARE UPGRADE	24
LED DESCRIPTION	25
INSTRUCTION OF V1 (ALSO KNOWN AS NAZA-M)	26
V1 ASSEMBLY AND CONNECTION.....	26
V1 IS COMPATIBLE WITH THE PMU V2 (ACCESSORY OF NAZA-M V2).....	26
V1 PORT DESCRIPTION.....	27
V1 SPECIFICATION.....	28
FAQ	29
ABNORMAL LED INDICATION LIST.....	29
FIX THE TBE (TOILET BOWL EFFECT) PROBLEM	29
SHOULD YOU FIND THE MULTI-ROTOR DOES NOT TRACK STRAIGHT IN FORWARD FLIGHT.....	30
MOTORS START FAILURE CAUSED BY TX STICK(S) MID POINT ERROR TOO BIG.....	30
ATTITUDE CONTROLLABLE WHEN ONE MOTOR OUTPUT IS FAILED	31
WHEN USED WITH OTHER DJI PRODUCTS.....	32

Instruction

Disclaimer & Warning

Please read this disclaimer carefully before using the product. By using this product, you hereby agree to this disclaimer and signify that you have read them fully. THIS PRODUCT IS NOT SUITABLE FOR PEOPLE UNDER THE AGE OF 18.

This product is an autopilot system designed for serious multi-rotor enthusiasts providing excellent self-leveling and altitude holding, which completely takes the stress out of flying RC multi-rotors for both professional and hobby applications. Despite the system having a built-in autopilot system and our efforts in making the operation of the controller as safe as possible when the main power battery is connected, we strongly recommend users to remove all propellers when calibrating and setting parameters. Make sure all connections are good, and keep children and animals away during firmware upgrade, system calibration and parameter setup. DJI Innovations accepts no liability for damage(s) or injuries incurred directly or indirectly from the use of this product in the following conditions:

1. Damage(s) or injuries incurred when users are drunk, taking drugs, drug anesthesia, dizziness, fatigue, nausea and any other conditions no matter physically or mentally that could impair your ability.
2. Damage(s) or injuries caused by subjective intentional operations. Any mental damage compensation caused by accident.
3. Failure to follow the guidance of the manual to assemble or operate.
4. Malfunctions caused by refit or replacement with non-DJI accessories and parts.
5. Damage(s) or injuries caused by using third party products or fake DJI products.
6. Damage(s) or injuries caused by mis-operation or subjective mis-judgment.
7. Damage(s) or injuries caused by mechanical failures due to erosion, aging.
8. Damage(s) or injuries caused by continued flying after low voltage protection alarm is triggered.
9. Damage(s) or injuries caused by knowingly flying the aircraft in abnormal condition (such as water, oil, soil, sand and other unknown material ingress into the aircraft or the assembly is not completed, the main components have obvious faults, obvious defect or missing accessories).
10. Damage(s) or injuries caused by flying in the following situations such as the aircraft in magnetic interference area, radio interference area, government regulated no-fly zones or the pilot is in backlight, blocked, fuzzy sight, and poor eyesight is not suitable for operating and other conditions not suitable for operating.
11. Damage(s) or injuries caused by using in bad weather, such as a rainy day or windy (more than moderate breeze), snow, hail, lightning, tornadoes, hurricanes etc.
12. Damage(s) or injuries caused when the aircraft is in the following situations: collision, fire, explosion, floods, tsunamis, subsidence, ice trapped, avalanche, debris flow, landslide, earthquake, etc.
13. Damage(s) or injuries caused by infringement such as any data, audio or video material recorded by the use of aircraft.
14. Damage(s) or injuries caused by the misuse of the battery, protection circuit, RC model and battery chargers.
15. Other losses that are not covered by the scope of DJI Innovations liability.

Trademark

DJI and Naza-M are registered trademarks of DJI Innovations. Names of product, brand, etc., appearing in this manual are trademarks or registered trademarks of their respective owner companies. This product and manual are copyrighted by DJI Innovations with all rights reserved. No part of this product or manual shall be reproduced in any form without the prior written consent or authorization of DJI Innovations. No patent liability is assumed with respect to the use of the product or information contained herein.

Certifications

This product is approved with quality standards such as CE, FCC and RoHS.

Symbol Instruction



Forbidden(Important)



Cautions



Tip



Reference

Assembly & Connection

In the Box:

Main controller X1, PMU X1, GPS X1, GPS Bracket X1, LED X1, Servo Cable X8, Micro-USB Cable X1, 3M Adhesive Tape.

Step1 Port Description

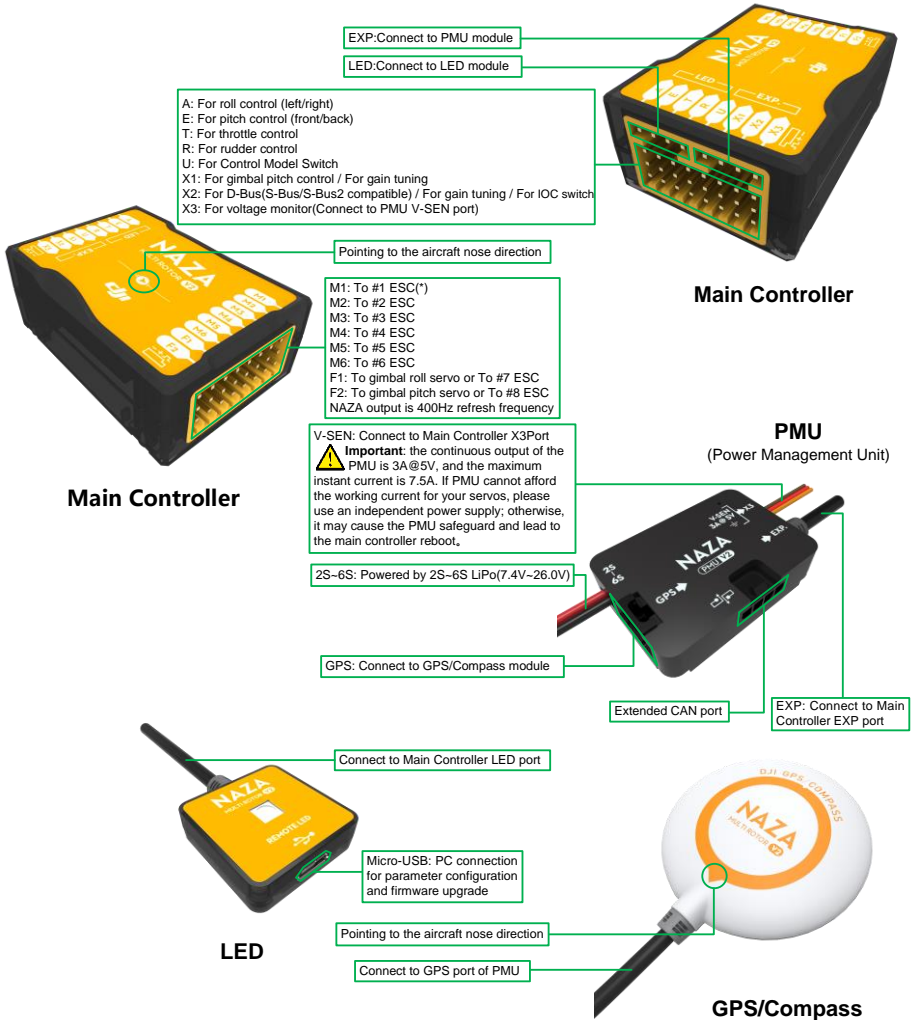

*ESC: Electronic Speed Controller

Step2 Assembly & Connection

Step1 Prepare an aircraft, supported the following **Mixed Types**.

The direction of the arrow in diagram indicates the rotation direction of the motor/propeller.

Important : To coaxial propellers: **Blue** propeller is at **TOP**; **Red** propeller is at **Bottom**. Otherwise all propellers are at top.

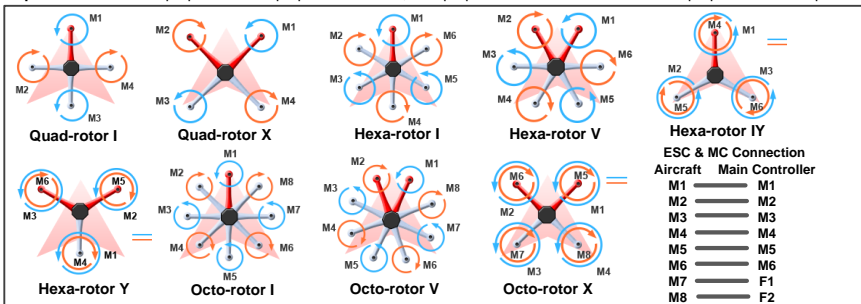

Note: The NAZA-M V2 flight control system doesn't support Gimbal function when used on the Octo-rotor aircraft. For big aircraft that is larger than 650 or with heavy load, WKM is recommended.

Step2 Assembly and Connection

Main Controller(MC)

Mount : (1)The DJI logo should face the sky, DO NOT mount the MC upside-down. (2)The MC sides should be parallel to the aircraft body. (3)The arrow should point to the nose direction of aircraft. (4)The MC is best positioned near the aircraft's center of gravity. Make sure all ports are accessible.

Tip : It is recommended to fix the MC until all wirings and configurations are completed, using 3M gummed paper provided to fix the MC.

ESCs & Motors

Please use the ESCs and motors recommended by the manufacturer of your aircraft. We recommend you use DJI motors and ESCs (Refer to its manual for details). Connect all ESCs to MC by the motor numbering method introduced in mixed types Supported .

Important : If you use 3rd party ESCs, make sure the ESCs travel midpoint is at 1520us. DO NOT use 700us travel midpoint ESC, as it may lead aircraft to fly away or cause injury and damage. After ESCs connection , calibrate ESCs one by one through the receiver directly before connect them to your MC, Make sure program all of them into Governor off, Break off and Normal Start up to get best experience.

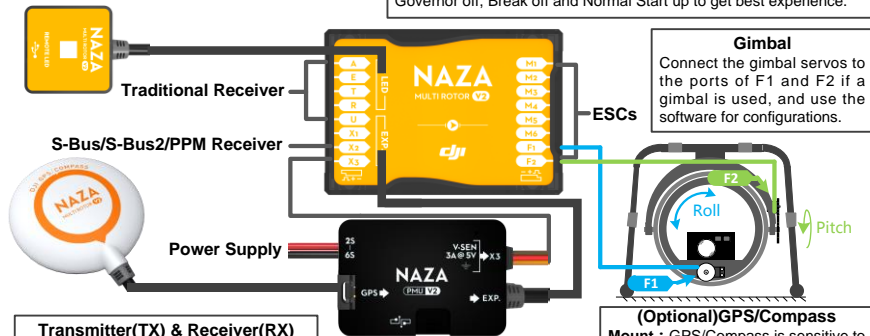

Transmitter(TX) & Receiver(RX)

(1)Refer to you TX Manual, setup the Aileron, Elevator, Throttle, Rudder channels on your TX first, and choose a 3-position switch as control mode switch.

(2)Attach the matched RX to aircraft, then connect your RX to the right ports on MC. The following diagram shows the connection example for traditional RX.

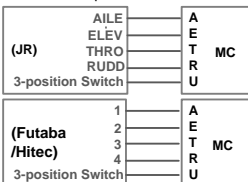

PMU Module

Mount : DO NOT attach the PMU on other device. Sufficient air flow over the PMU is highly recommended.

Tip : If use with DJI multi-rotor, you can solder the power cable to power pads on frame bottom board. Please refer to DJI multi-rotor manual for details. If use with 3rd part aircraft, you can make a connector by yourself to connect PMU and battery.

LED Module

Mount : Make sure You can see the light during the flight. Leave the USB interface to be accessible. Use the 3M gummed paper provided to fix.

Gimbal

Connect the gimbal servos to the ports of F1 and F2 if a gimbal is used, and use the software for configurations.

(Optional)GPS/Compass

Mount : GPS/Compass is sensitive to magnetic interference, should be far away from any electronic devices. If you use your own mounting rod, make sure it is NOT magnetic!

Procedures :

(1)You should use epoxy resin AB glue to assemble the GPS bracket first. Mount the bracket on the center plate of craft. Position the bracket at least 10 cm from any propeller. (2)The DJI logo marked on the GPS should face the sky, with the orientation arrow pointing directly forward. then fix the GPS on the plate of the bracket (by 3M glue provided).

Tip : The GPS/Compass is packaged with a special indication line for mounting for the first time.

Step3 Double Check

In this step, turn on the transmitter, connect the battery to the PMU, and then watch the LED, if you can see the LED blinks (●●●●●●●●●●●●●●●●), the system is working.

Assistant Software Installation and Configuration

Step1 Software and Driver Installation

Installing and running on Windows

1. Please download the driver and the Assistant installation software in **EXE** format from www.dji.com.
2. Switch on the transmitter and then power on your autopilot system.
3. Connect your autopilot system and PC via a Micro-USB cable.
4. Open the driver installation software and follow the instructions to complete installation.
5. Run the Assistant installation software and follow the instructions to complete installation.



The installer in EXE format is supported on Win XP, Win7, Win8 (32 or 64 bit).

Installing and running on Mac OS X

1. Download the Assistant installer in **DMG** format from the download page of NAZA-M V2 on the DJI website.
2. Run the installation software and follow the prompts to finish installation.



3. **When launching for the first time** if use Launchpad to run the NAZA-M V2 Assistant Software, Launchpad won't allow access because the software has not been reviewed by Mac App Store.

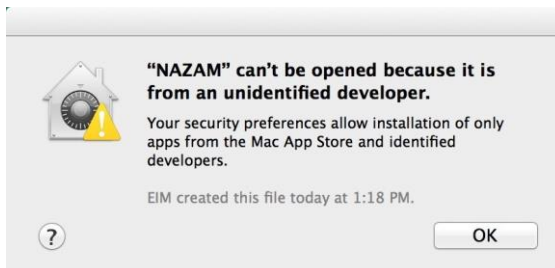

4. Locate the NAZA-M V2 icon in the Finder and open the file by Control or right clicking the icon and selecting “Open” from the menu.
5. After the first successful launch, double-clicking the NAZA-M V2 icon in the Finder or using Launchpad will open the application.

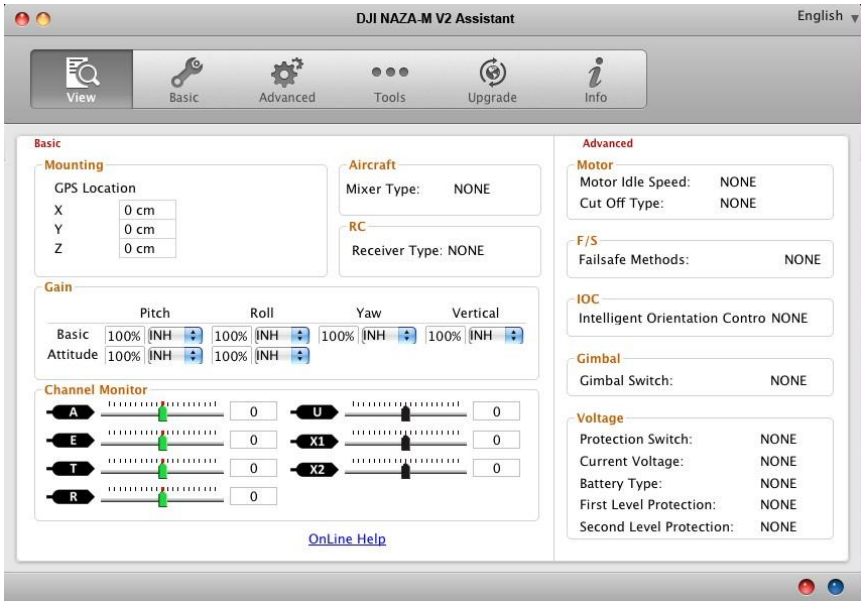

Installer in DMG format is supported on Mac OS X 10.6 or above.



The NAZA-M V2 Assistant on Mac OS X and Windows are exactly the same. The Assistant appear in other places of this manual is based on Windows version.

Step2 Configuration by Assistant on a PC

1. Power on the PC. Make sure your computer is connected to the Internet for the first time you use.
2. Switch on the transmitter first, and then power on the autopilot system. Connect the autopilot system to the PC with a Micro-USB cable. DO NOT break the connection until setup is finished.
3. Run the Assistant Software.
4. Observe the indicators on the left bottom of the software. ( They are the connection indicator and communication indicator in order.) If the communication indicator is blinking, that the software is ready, please go to next step.
5. Select the “Info” option. Check the software firmware version. If the upgrade is available, you may update the assistant software.

6. Select the “Upgrade” option. Check the Main Controller, GPS and IMU firmware version.
7. Select the “Basic” option. Please follow step-by-step for your first-time-configuration. Basic configuration is necessary, including Mixer Type, Mounting, RC, and Gain settings.
8. You can click the “Advanced” option for more parameter settings. Advanced setting is optional. There are settings of Motor, FailSafe, Intelligent Orientation Control (IOC), Gimbal, Low-Voltage Alert, and Flight Limits. Read the instruction in the assistant software to obtain more details.
9. Select the “Viewer” option to check all parameters.
10. Then break the Micro-USB cable, power off the aircraft. Finished.



- (1) You may be required to fill register information for your first-time-usage.
- (2) If the communication indicator is blue on, please double check the connections.
- (3) Basic configuration is necessary before you go to the “Basic Flying Test”.
- (4) Users are required to install a Windows system, since the software can only run on Windows system .



- (1) If the firmware upgrade is available, please upgrade it by referring to the Firmware Upgrade in the Appendix.
- (2) This step is required to use together with the assistant software to obtain more details.

Recommended Parameters

Recommended Settings for using F330/F450/F550

	Configuration Information					Basic Gain				Attitude Gain	
	Motor	ESC	Propeller	Battery	Weight	Pitch	Roll	Yaw	Vertical	Pitch	Roll
F330	DJI-2212	DJI-18A	DJI-8 Inch	3S-2200	790 g	140	140	100	110	140	140
F450	DJI-2212	DJI-30A	DJI-8 Inch	3S-2200	890 g	150	150	100	105	150	150
F550	DJI-2212	DJI-30A	DJI-8 Inch	4S-3300	1530 g	170	170	150	140	170	170

Basic Flying

Control Mode Knowledge

Please read the Control Mode Knowledge clearly before usage, to know how to control the aircraft.

Different control modes will give you different flight performances. Please make sure you understand the features and differences of the three control modes.

	GPS ATTI. Mode (With GPS Module)	ATTI. Mode	Manual Mode
Rudder Angular Velocity	Maximum rudder angular velocity is 150°/s		
Command Linearity	YES		
Command Stick Meaning	Multi attitude control; Stick center position for 0° attitude, its endpoint is 35°.		Max-angular velocity is 150°/s. No attitude angle limitation and vertical velocity locking.
Altitude Lock	Maintain the altitude best above 1 meter from ground.		NO
Stick Released	Lock position if GPS signal is adequate.	Only attitude stabilizing.	NOT Recommend
GPS Lost	When GPS signal has been lost for 3s, system enters ATTI. Mode automatically.	Only performing attitude stabilizing without position lock.	---
Safety	Attitude & speed mixture control ensures stability		Depends on experience.
	Enhanced Fail-Safe(Position lock when hovering)	Auto Level Fail-Safe (Attitude stabilizing)	
	With GPS/Compass module and the failsafe requirements are satisfied, in each Control Mode (including GPS Mode, ATTI. Mode, Manual Mode and IOC Mode), the aircraft will enter the failsafe Mode.		
Applications	AP work	Sports flying.	---

Start & Stop Motor Knowledge



- (1) Both Immediately Mode and Intelligent Mode are available in the Assistant Software: Advanced->Motor->Stop Type.
- (2) Stop Motor method is defaulted to Immediately Mode.

Please get to know well about this section before flying.

- 1 **Start Motor:** Pushing throttle stick before takeoff will not start the motors. You have to execute any one of following four Combination Stick Commands (CSC) to start the motors:



2 Stop Motor: We provide two options to stop motors in the assistant software: Immediately and Intelligent.

- (1) **Immediately Mode:** If you select this mode, in any control mode, once motors start and throttle stick is over 10%, motors will not stop immediately only when throttle stick is back under 10% the motors will stop. In this case, if you push the throttle stick over 10% within 5 seconds after motors stop, motors will re-start, CSC is not needed. If you don't push throttle stick after motors start in three seconds, motors will stop automatically.
- (2) **Intelligent Mode:** By using this mode, different control mode has different way of stopping motors. In Manual Mode, only executing CSC can stop motors. In ATTI. Mode or GPS ATTI. Mode, any one of following four cases will stop motors:
 - a) You don't push throttle stick after motors start within three seconds;
 - b) Executing CSC;
 - c) Throttle stick under 10%, and after landing for more than 3 seconds.
 - d) If the angle of multi-rotor is over 70°, and throttle stick under 10%.

Notes of Intelligent Mode



- (1) In ATTI. / GPS ATTI. Mode, it has landing judgment, which will stop motors.
- (2) Start motors in ATTI. / GPS ATTI. Mode, you have to execute CSC and then push throttle stick over 10% in 3 seconds, otherwise motors will stop after 3 seconds.
- (3) During normal flight, only pull throttle stick under 10% will not stop motors in any control mode.
- (4) For safety reason, when the slope angle of multi-rotor is over 70° during the flight in ATTI. / GPS ATTI. Mode (may be caused by collision, motor and ESC error or propeller broken down), and throttle stick is under 10%, motors will stop automatically.

Notes of Intelligent Mode & Immediately Mode



- (1) If you choose the Immediately Mode, you should not pull throttle stick under 10% during flight, because it will stop motors. If you do it accidentally, you should push the throttle stick over 10% in 5s to re-start motors.
- (2) DO NOT execute the CSC during normal flight without any reason, or it will stop motors at once.



- (1) If you choose the Intelligent mode, and the throttle stick is under 10%, this will trigger the landing Procedure, in any control mode. In this judgment, pitch, roll and yaw controls are denied except the throttle, but multi-rotor will still auto level.
- (2) In any control mode, DO NOT pull throttle stick under 10% during normal flight without any reason.



- (1) Any of these two cut off types will only work properly if TX calibration is correct done.
- (2) In failed-safe, CSC is denied by the main controller, motors will hold their state.

Step1 Compass Calibration

Without GPS module, please skip this step. If you use with GPS module, follow step-by-step for calibration.

- (1) DO NOT calibrate your compass where there is magnetic interference, such as magnetite, car park, and steel reinforcement under the ground.
- ❌ (2) DO NOT carry ferromagnetic materials with you during calibration, such as keys or cell phones.
- (3) Compass module CANNOT work in the polar circle.
- (4) Compass Calibration is very important, otherwise the system will work abnormal.

Calibration Procedures

1. Switch on the transmitter, and then power on autopilot system!
2. Quickly switch the control mode switch from *GPS Mode* to *Manual Mode* and back to *GPS Mode* (or from *GPS Mode* to *ATTI. Mode* and back to *GPS Mode*) for more than 5 times, The LED indicator will turn on constantly yellow so that the aircraft is ready for the calibration.
3. (Fig.1) Hold your Multi-rotor horizontal and rotate it around the gravitational force line (about 360°) until the LED changes to constant green, and then go to the next step.
4. (Fig.2) Hold your Multi-rotor vertically and rotate it (its nose is downward) around the gravitational force line (about 360°) until the LED turns off, meaning the calibration is finished.

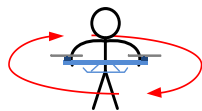

Fig.1

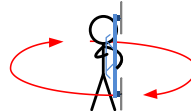



Fig.2

5. If the calibration was successful, calibration mode will exit automatically. If the LED keeps flashing quickly Red, the calibration has failed. Switch the control mode switch one time to cancel the calibration, and then re-start from step 2.



1. When the GPS is abnormal, the Main controller will tell you by the LED blinking Red and Yellow alternately (), disable the GPS Module, and automatically enter the aircraft into the ATTI. Mode.
2. You don't need to rotate your multi-rotor on a precise horizontal or vertical surface, but keep at least 45° difference between horizontal and vertical calibration.
3. If you keep having calibration failure, it might suggest that there is very strong magnetic interference around the GPS /Compass module, please avoid flying in this area.
4. When to do re-calibration
 - (1) The flight field is changed.
 - (2) When the multi-rotor mechanical setup has changed:
 - a) If the GPS/Compass module is re-positioned.
 - b) If electronic devices are added/removed/ re-positioned (Main Controller, servos, batteries, etc.).
 - c) When the mechanical structure of the multi-rotor is changed.
 - (3) If the flight direction appears to be shifting (meaning the multi-rotor doesn't "fly straight").
 - (4) The LED indicator often indicates abnormality blinking when the multi-rotor spins. (It is normal for this to happen only occasionally)

Step 2 Assembly Checking List

Please check each item, to make sure for safety.

Any of the following mistakes will lead to a dangerous accident, double check all these items:



- (1) Rotation direction of motor is opposite
- (2) Infirm connection between the motor and the ESC
- (3) Wrong or infirm installation of Main controller
- (4) Wrong or infirm connection between the main controller and ESC.
- (5) Propeller installation mistake
- (6) Magnetization of the compass

Make sure the following items are correct.



- (1) Make sure you have assembled your multi-rotor correctly.
- (2) Make sure you have done the configuration procedure correctly.
- (3) Make sure all connections are in good condition.
- (4) Make sure batteries are fully charged for your transmitter, autopilot system and all devices.

Step 3 Before Flight

Carry out the following procedures (is based on Intelligent Mode of Motor Stop) to make sure all configurations are correct. Refer to the Appendix->LED Description for more LED details.

1. Always switch on the transmitter first, then power on multi-rotor!
2. Keep the aircraft stationary until the system start and self-check has finished (●●●●●●●●●●). After that, the LED may blink Yellow 4 times quickly (●●●●). Start motor is disable during LED blinking Yellow 4 times quickly (●●●●), as the system is warming up.
3. After the 4 times Yellow LED disappears, toggle the control mode switch on your transmitter to make sure it is working properly. For example, LED blinks (●●●●●●●●), which means the system is in ATTI. Mode and the GPS signal is worst Check it with LED indicator to specify the current working mode for MC. See following table for details about LED indicator;
 - (1) There are Manual Mode and ATTI. Mode without a GPS/Compass module, no GPS signal status LED indicator.
 - (2) After connecting to the GPS/Compass module, GPS ATTI. Mode is available, and GPS signal status LED indicator is available.

Control Mode LED Indicator	GPS Signal Status LED Indicator
Manual Mode: NO LED	Signal is best (GPS satellites > 6) : NO LED
ATTI. Mode: ● (●● indicates that is stick(s) not at center)	Signal is well (GPS satellites = 6) : ●
GPS Mode: ● (●● indicates that is stick(s) not at center)	Signal is bad(GPS satellites = 5) : ●●
	Signal is worst (GPS satellites < 5) : ●●●

4. Keep the aircraft stationary, and then push both sticks to the left bottom or right bottom (shown as the following chart, defined as Combination Stick Commands (CSC)), to start the motors.



5. Release the yaw, roll and pitch sticks and keep them at the mid point, and the throttle stick under the mid point. Then check whether all propellers are rotating correctly.
6. Stop motors, power off the Multi-rotor.
7. Make sure all settings and configurations are correct and then you can take off you aircraft.

After power on, if abnormal LED Indicator occurs, please refer to the Abnormal LED instruction in the FAQ and aids troubleshooting.

Step4 Flying Test

1. Choose an open space without obstruction, tall buildings and crowds as flying filed. Place the aircraft 3 meters away from you and others, to avoid accidental injury.
2. If in GPS ATTI. Mode, place the aircraft in an open space without buildings or trees. Take off the aircraft after 6 or more GPS satellites are found (Red LED blinks once or no blinking). If in Manual Mode or ATTI. Mode, you can skip this step.
3. Start-up
 - (1) Switch on the transmitter first, then power on multi-rotor! Keep the aircraft stationary until the system start and self-check has finished.
 - (2) Please wait for the system to warm up gradually with the LED blinks Yellow 4 times quickly (●●●●). You should not start the motors until the blinking disappears.
 - (3) Keep the aircraft stationary, and execute the CSC to start the motors.
 - (4) Release the yaw, roll and pitch sticks and keep them at the mid point, at the same time raise the throttle stick from the bottom. The motors will stop if you do not push the throttle stick from the bottom within 3 sec and you will need to re-start the motors.
 - (5) Keep raising the throttle stick until all the rotors are working, push the throttle stick to the mid point and then take-off your multi-rotor gently, pay attention not to push the stick excessively.
 - (6) Pay attention to the aircraft movement at any time when flying, and use the sticks to adjust the aircraft 's position. Keep the yaw, roll, pitch and throttle sticks at the mid point to hover the aircraft at the desired height.
4. Lower the aircraft slowly. Pull the throttle stick to the bottom and then execute the CSC to stop the motors after landing.
5. Please always power off the Multi-rotor first, and then switch off the transmitter after landing.

FLYING NOTES(VERY IMPORTANT) !!!

- (1) If the warm up waiting is longer than 2 minutes (the 4 times Yellow blink continues), please power off for 10 minutes, cold start, and then connect the assistant software, enter the "Tools" -> IMU calibration, carry out the Advanced calibration.
 - (2) If you enable the Immediately Mode of Motor Stop; you should not pull throttle stick under 10% during flight, because it will stop motors. If you do it accidentally, you should push the throttle stick over 10% in 5s to re-start motors.
 - (3) DO NOT execute the CSC during normal flight without any reason, or it will stop motors at once.
 - (4) Pay attention to the GPS satellite status LED indicator. Bad GPS signal may lead the aircraft to drift when hovering.
-  (5) DO NOT fly near to ferromagnetic substances, to avoid strong magnetic interference with the GPS.
- (6) Please avoid using GPS ATTI. Mode in the areas, where GPS signal is most likely bad.
 - (7) If the LED flashes quickly Red then this indicates battery voltage is low, land ASAP.
 - (8) If the transmitter indicates low-battery alarm, please land ASAP. In this condition the transmitter may cause the aircraft to go out of control or even crash.
 - (9) In GPS ATTI. Mode, make sure that the home point is recorded when the GPS signal is well; otherwise the home point recording may be not so precise.

- (1) In ATTI Mode, throttle stick center position is for 0m/s along the vertical direction. You should keep the position of throttle stick higher than 10% from cut-throttle during the flight! In any control mode, DO NOT pull throttle stick under 10% during normal flight without any reason.
-  (2) It is recommended to land the aircraft slowly, to prevent the aircraft from damage when landing.
- (3) If Low-Voltage Alarm is set, the aircraft will act according to the configuration of the Assistant Software once Low-Voltage Alarm is triggered. Make sure you remember what you have set before.
 - (4) If Fail-Safe function is set, the aircraft will act according to the configuration of the Assistant Software once Fail-Safe is triggered. Make sure you remember what you have set before.

Advanced Functions

A1 FailSafe

An introduction of Go-Home and Landing.

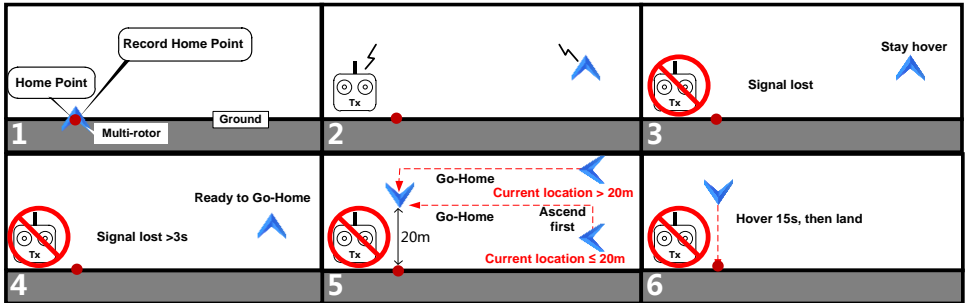

Home-point: Before takeoff, current position of multi-rotor will be saved as home-point by MC automatically when you start the motors for the first time after 6 or more GPS satellites are found (red light blinks once or no blinking) for 10 seconds.

Note

1. Please make sure to record the home-point before takeoff, and clearly know where it is.
2. During go-home the nose direction of the aircraft is facing toward the home-point, the aircraft is flying directly from the current position to the home-point.
3. You can regain the control during the aircraft is hovering 15 seconds.

The flowchart of failsafe and how to regain control

This section will demonstrate the working logic of failsafe and how to regain control.

The following description is effective only when:

1. The aircraft is in flight.
2. The GPS works normally and signal is good (≥ 6 satellite, the LED blinks a single red light or no red light).

- What triggered failsafe
- The aircraft behavior after failsafe
- How to regain control
- Precautions

<p>(1) The aircraft flies far away, TX is on but the signal is weak.</p>	<p>Attitude Mode: (1) the aircraft will level its attitude immediately (2) 3 seconds later, failsafe is triggered and aircraft will start to go home. (3) If signal is regained during (1) or (2), it will resume normal flight immediately.</p> <p>GPS Mode: (1) the aircraft will slow down and hover. (2) if the signal is restored within 3 seconds (TX and receiver connected), the system will immediately return to normal operation; does not enter failsafe. (3) if not reconnected within 3sec, the system will enter failsafe, then even if the signal is restored, the system will not exit failsafe.</p>	<p>Attitude Mode: In Attitude Mode as soon as you get signal you can regain control.</p> <p>GPS Mode: switch the TX mode switch to ATTI, if the receiver is connected, then you will regain control.</p>
--	---	--

<p>(2) Turn off the TX (we assume you want to trigger failsafe)</p>	<p>In this case, the behavior of the aircraft is the same as in the above condition.</p> <p>If you want the aircraft to Return Home, please do not turn the TX back on within 3 seconds*, otherwise the aircraft will exit failsafe mode immediately.</p>	<p>If you choose to turn off the TX, you must be pretty sure that you know how to regain control. Here we offer a method, please read carefully.</p>
---	---	--

<p>We strongly recommend you DO NOT try this, because there are three types of risk:</p> <ol style="list-style-type: none"> (1) You must be pretty clear whether the Home-point is OK for landing or not. (You have to understand the definition of Home-point well and the working process of failsafe) (2) If there are tall buildings around, the aircraft may be obstructed on the way. (3) When GPS signal is bad or GPS is not working, failsafe will not work. 	<p>When you turn off the TX, use the following method to regain control:</p> <ol style="list-style-type: none"> (1) Switch the TX switch to GPS. (2) then put throttle to the center position (greater than 3sec after switching off, important), you can now turn the TX back on. (3) then you can switch the TX Control mode switch to ATTI to regain control.
---	--

Note: if you start the motors, but do not push the throttle to take-off the aircraft, in this case it is very dangerous to turn off the TX, because the aircraft will take off automatically, so do not try this.

* If signal lost for more than 3 seconds failsafe will be triggered, if signal regained within 3 seconds it will exit failsafe immediately.

A2 Low-Voltage Alert

In order to prevent your multi-rotor from a crash or other harmful consequences caused by low battery voltage, there are two levels of low voltage protection available to use. You can choose to use or not to use them; however we strongly recommend using the protections if available! Low-Voltage Alert is to indicate that the battery cannot provide enough power for the aircraft, in order to warn you to land the aircraft ASAP. You can configure this function in the assistant software, and please read the text in the software carefully before your flight. Make sure to carry out the Current Voltage Calibration.

There are both first level and second level protections. The first level protection has LED warning. During second level protection the aircraft will land automatically with LED warning. Meanwhile the center point of throttle stick will move up slowly to 90% of endpoint, you should land ASAP to prevent your aircraft from crashing!

It is not for fun, you should land your aircraft ASAP to prevent your aircraft from crashing or other harmful consequences!!!



- (1) Configure the FailSafe function in the **assistant software** -> **"Advanced"** -> **"F/S"** and read the instruction thoroughly and carefully.
- (2) Configure the Low-Voltage Alert function in the **assistant software** -> **"Advanced"** -> **"Voltage"** and read the instruction thoroughly and carefully.

A3 Intelligent Orientation Control (IOC) Flight (with GPS module)

Definition of Forward Direction:

Multi-rotor will fly along this direction when you push the elevator stick (→).

Step 1/Before You Start

Usually, the forward direction of a flying multi-rotor is the same as the nose direction. By using IOC, wherever the nose points, the forward direction has nothing to do with nose direction. The red and blue arrows on the transmitter are corresponding to pitch and roll operations in the following diagram.

- In course lock flying, the forward direction is the same as a recorded nose direction. All the following requirements are met: the autopilot system is in ATTI. Mode or GPS ATTI. Mode.

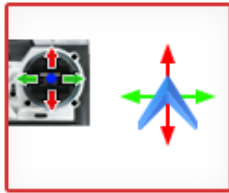

Normal flying

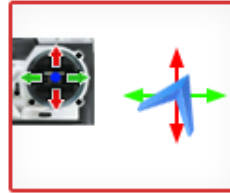

Course Lock Flying

- In home lock flying, the forward direction is the same as the direction from home point to multi-rotor. All the following requirements are met: 6 or more GPS satellites are found, in GPS ATTI. Mode, and the aircraft is further than 10m away from the home point.



Normal flying

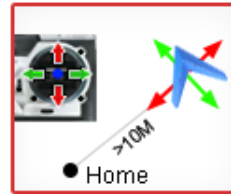

Home Lock Flying

Step 2/IOC Switch Setting

Before using the IOC function, you have to choose a 3-position switch on your transmitter as the IOC switch, which is also used for recording the orientation, home position in corresponding modes. Refer to the assistant software; click the "Advanced" to find the "IOC".

IOC Switch			
IOC Function	OFF	Course Lock	Home Lock



The above table is for example. The function of the switch position may be reversed since the normal/reversed setting of the switch channel. Toggle the switch and observe the slider position of channel X2 on the assistant software screen, the corresponding area should turn blue.

Step 3 Method of Forward Direction and Home Point Recording

If you use the IOC function, **please be aware of the Forward Direction of Course Lock Flying, and the home point of Home Lock Flying.** There are two ways to record the forward direction and the home point: Manually and Automatically. You may choose any one record method. The LED will blink Green quickly if successfully recorded.

	Course Lock	Home Lock
Automatically	30 seconds after you power on the autopilot system.	Before takeoff, the current position of the aircraft will be saved as home point when you start the motors for the first time after 6 or more GPS satellites have been found for 10 seconds.
Manually	30 seconds after you power on the autopilot system. Toggle the IOC switch from Off to Course Lock, and back to Off quickly 3 to 5 times.	After 6 or more GPS satellites have been found. And the aircraft can be hovering. Toggle the IOC switch from Course Lock to Home Lock, and back to Course Lock quickly 3 to 5 times.



DO NOT toggle the switch between Off to Home Lock, since it may change the recording of the **Forward Direction of Course Lock.**

Step 4 IOC Flying Test

Then you can do **Course Lock and Home Lock flying test.**

Carry out an IOC flight by the following procedure. The Control Mode LED will blink Yellow and Green alternatively (●●) to indicate the IOC mode only when the main controller is really to fly in Course Lock, Home Lock modes.

During the same flight	STEP1: Record	STEP2: ON	STEP3: OFF	STEP4: ON again
Course Lock				
Switch Setting	Record the Forward Direction	Set Control Mode switch at GPS or ATTI. position, Toggle IOC switch from OFF to Course Lock position	Toggle IOC switch to OFF position	Toggle IOC switch from OFF to Course Lock position
Home Lock				
Switch Setting	Record the Home Point	Set Control Mode switch at GPS position, Toggle IOC switch from OFF to Home Lock position	Toggle IOC switch to OFF position	Toggle IOC switch from OFF to Home Lock position

Aircraft moving direction when pull pitch stick Aircraft moving direction when pull roll stick

● Home point Aircraft (the arrow is pointing to the direction of the aircraft nose)

IOC FLYING NOTES !!!













- (1) When Multi-rotor is flying by home lock far away from you and the home point, please DO NOT toggle the IOC switch many times quickly so as to avoid the change of home point without your attention.



- (1) Home lock flying requires that 6 or more GPS satellites are found and the aircraft is further than 10m away from the home point.
- (2) If the IOC flying requirement is not satisfied, the autopilot system will quit IOC control mode. Please be aware of the LED indicator, to know the current control mode of the autopilot system.



- (1) Blinking indications of IOC   are:
 - a) Before motors start:   **blink**, all sticks (except throttle stick) return to center;   **blink**, stick(s) (except throttle stick) not at center.
 - b) After motors start and throttle stick is over 10% in 3 seconds:   **blink**, all sticks return to center;   **blink**, stick(s) not at center.
- (2) Before you do the home lock flight, you have to fly the aircraft out of the 10m range around home point, and then flip the IOC switch to Home Lock position to fly in home lock when all the requirements are met. If you have already toggled the IOC switch to Home Lock position when the aircraft is still in 10m range around home point, and this is the first time you are going to fly in home lock during the current flight, then if all the requirements are met, the main controller will change into home lock automatically when Multi-rotor flies out the 10m range around home point.
 - (1) When flying in Home Lock mode, if any of the following situations happen, then the system will quit Home Lock flying and automatically enter Course Lock flying. The aircraft will fly in Course Lock using the earlier forward direction.
 - a) The aircraft fly 's within 10m range of the home point.
 - b) You toggle the control mode switch to the ATTI. Mode.
 - c) The GPS signal becomes bad (The GPS signal LED is blinking Red twice or three times).
 - (2) We suggest that you should know clearly which flight lock method you are going to fly, and you know the locked forward direction or home point, before you switch on IOC mode during the flight.

A4 Receiver Advanced Protection Function

You are asked to enable this function by connecting to the Assistant Software, please set it at the section of Basic->R/C-> Receiver Advanced Protection.

If you choose enable it, the FailSafe will be triggered if the following situations occur during flight.

According to the difference of the aircraft height, there are two situations.

- a) Lower than 100m, the A/E/R channel is not at the mid point.
- b) Higher than 100m, the A/E/R channel is not at the mid point or the throttle stick is above the mid point.

In the GPS Mode or ATTI. Mode, if the requirement a) or b) is satisfied, and the output data of four channels A/E/R/T have not changed for 20 seconds, then the aircraft will hover automatically. After that, if the output data of four channels A/E/R/T still do not any changes and last for 10 seconds, the autopilot system will think that the data from receiver is abnormal, and then enter the FailSafe Mode.

Brief introduction of how to quit the FailSafe Mode

If there is any command change from the receiver, the autopilot system thinks that the receiver is regained. In ATTI. Mode and Manual Mode, it will quit the FailSafe Mode automatically. In GPS Mode, please toggle the control mode switch to the ATTI. Mode and Manual Mode position to regain the control. Refer to the FailSafe section for more details.

A5 Flight Limits

The flight limits function is default enabled in the NAZA-M Flight control system, it's aimed to restrict the flying height and distance of the aircraft. The Max Height restricts the vertical distance between the aircraft and the Home point, the Max Radius restricts the horizontal distance between the aircraft and the Home point.

The default Max Height is 2000m and Max Radius is 2000m. Users can write the values of the Max Height and Max Radius in the Assistant software, the range of the Max Height is 10m-100000m, the range of the Max Radius is the same. So that the aircraft will fly in the entered range, which is a cylinder space above the Home point.

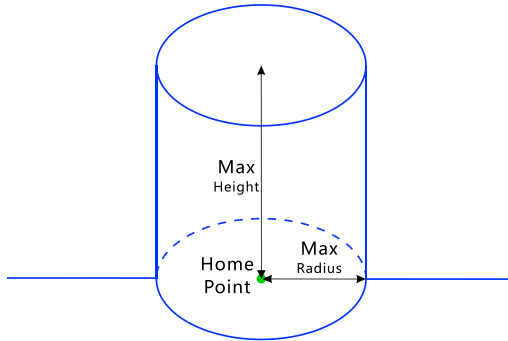

- (1) Height Limit works when the control mode is GPS or ATTI. Mode. Radius Limit works when the control mode is GPS and the satellite number ≥ 6 .
- (2) If the aircraft flies out of the limits, it's still controllable except flying further away.
- (3) If the control mode is changed to GPS when the aircraft is out of Max Radius, the aircraft will fly back within the entered range.
- (4) The Failsafe and the Ground Station operations are not restricted to the Flight Limits.

Appendix

Specifications

General	
Built-In Functions	(1) Three Modes of Autopilot (4)S-Bus/S-Bus2 Receiver Support
	(2)Enhanced Fail Safe (5)PPM Receiver Support
	(3)Low Voltage Protection (6)2-axle Gimbal Support
Peripheral	
Supported Multi-rotor	<ul style="list-style-type: none"> ● Quad-rotor I4, X4; ● Hexa-rotor I 6, X6, IY6, Y6. ● Octo- rotor I8, V8, X8
Supported ESC output	400Hz refresh frequency.
Recommended Transmitter	PCM or 2.4GHz with a minimum 4 channels.
Assistant Software System Requirement	Windows XP SP3; Windows 7; Windows 8
Electrical & Mechanical	
Working Voltage Range	<ul style="list-style-type: none"> ● MC: 4.8V ~ 5.5 V ● PMU Input: 7.4V ~ 26.0 V (recommend 2S ~ 6S LiPo) Output(V-SEN port red wire): 3A@5V Output(V-SEN port red wire)burst current:7.5A
Power Consumption	<ul style="list-style-type: none"> ● MAX: 1.5W(0.3A@5V) ● Normal: 0.6W(0.12A@5V)
Operating Temperature	-10°C ~ 50°C (14F ~122F)
Weight	<ul style="list-style-type: none"> ● MC: 27g ● GPS/Compass: 27g ● PMU: 28g ● LED: 13g
Dimensions	<ul style="list-style-type: none"> ● MC: 45.5mm × 32.5mm × 18.5mm ● GPS/Compass: 46mm (diameter) x 10mm ● PMU : 39.5mm × 27.5mm × 10.0mm ● LED : 25mm × 25mm × 7.0mm
Flight Performance (can be effected by mechanical performance and payloads)	
Hovering Accuracy (GPS Mode)	<ul style="list-style-type: none"> ● Vertical: ± 0.8m ● Horizontal: ±2.5m
Max Yaw Angular Velocity	200° /s
Max Tilt Angle	35°
Max Ascent / Descent Speed	Ascent : 6m/s, Descent : 4.5 m/s

MC/PMU Firmware Upgrade

Please follow the procedure for software and firmware upgrade; otherwise the system might not work properly. For

SAFETY REASONS, DO NOT use power battery during firmware upgrade.

1. Make sure your computer is connected to the Internet.
2. Please close all the other applications during the firmware upgrade, including anti-virus software and firewall.
3. Make sure the power supply is securely connected. DO NOT un-plug the power supply until firmware upgrade has finished.
4. Connect system to PC with Micro-USB cable, DO NOT break connection until firmware upgrade is finished.
5. Run Software and wait for connection.
6. Select **Upgrade** option→Check the MC and PMU Firmware Version.
7. DJI server will check your current firmware version, and get the latest firmware prepared for the unit.
8. If there is a firmware version more up-to-date than your current version, you will be able to click to update them.
9. Wait until Assistant software shows "finished".
10. Click **OK** and power cycle the unit after at least 5 seconds.
11. Your unit is now up-to-date.



- (1) After firmware upgrade, please re-configure the system using Assistant software.
- (2) If firmware upgrade failed, the system will enter waiting for firmware upgrade status automatically, please try again with the above procedures.
- (3) Select **Upgrade** option→Check the GPS Firmware Version, online upgrade is disable.

LED Description

System Status	LED Flashing
System start and self-check	
IMU abnormal data or need advanced calibration*	
Warm up after power on	
The aircraft is moved or bias of sensors too big	
Compass error too big, need recalibration.	
Transmitter (TX) signal lost, enter the FailSafe.	
TX stick(s) mid point error too big	
Low voltage alert or other abnormal alert* (e.g. Configuration error, TX data error, Enable low voltage protection without PMU, SN error or Compass abnormal work.)	
Record forward direction or home point	
Control Mode Indicator	Manual Mode: None ATTI Mode: (stick(s) not at center) GPS Mode: (stick(s) not at center) IOC Mode: (stick(s) not at center)
GPS Signal State Indicator (GPS/Compass Module is necessary)	GPS Signal is Best(GPS Satellite number > 6): None GPS Signal is Well(GPS Satellite number = 6): GPS Signal is Bad (GPS Satellite number = 5): GPS Signal is Worst (GPS Satellite number < 5):

Compass Calibration	LED Flashing
Begin horizontal calibration	
Begin vertical calibration	
Calibration or others error	

*You can figure out the error by connecting the autopilot system to the assistant software.

Instruction of V1 (also known as NAZA-M)

V1 (also known as NAZA-M) system is different from V2 system, if you are V1 system user, please read the following text carefully, and refer to the other text in this Guide for usage details (including **Assistant Software Configuration**, **Basic flying**, **Advanced Function Appendix** and **FAQ**, etc.) .

V1 Assembly and Connection

Connect the V1 system according to the following chart.

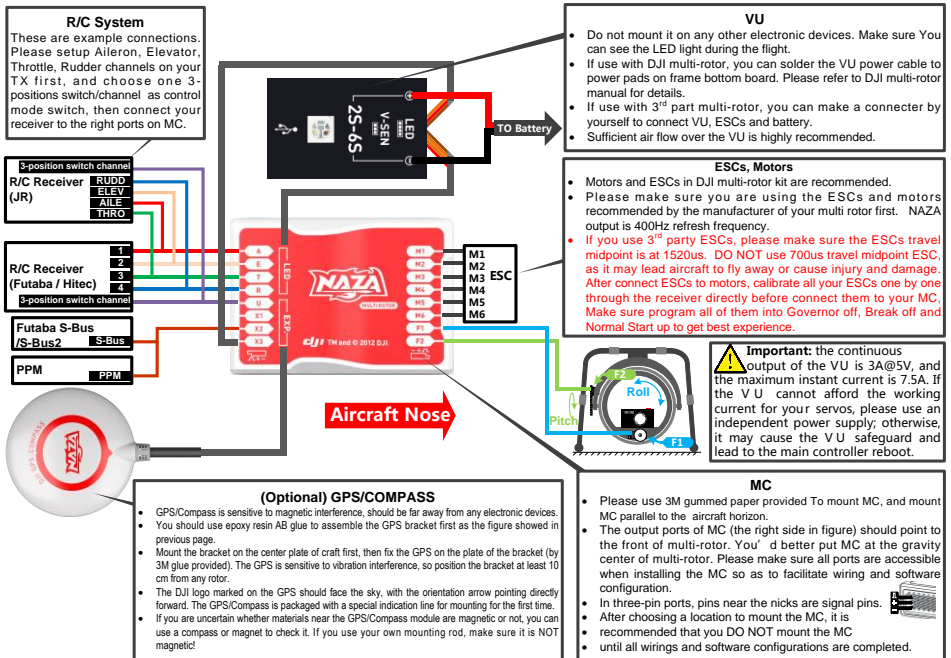

V1 is compatible with the PMU V2 (Accessory of Naza-M V2)





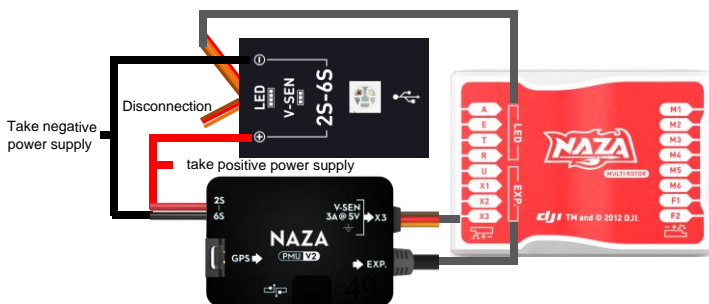













V1 system is compatible with the PMU V2 of V2 system; please carry out the following connection. The other modules connection is the same as before.

Important: You are asked to upgrade your Firmware version of V1 MC to V3.10 or above, as the PUM V2 can only work with the MC of version 3.10 or above.



VI Port Description

Please remember the function of each port, which may help you to use the Naza-M efficiently.

Main Controller		
	A	For roll control (left/right)
	E	For pitch control (front/back)
	T	For throttle control
	R	For rudder control
	U	For Control Mode Switch
	X1	For gimbal pitch control
	X2	For D-Bus (S-Bus/ S-Bus2 compatible)
	X3	For voltage monitor (Connect with VU V-SEN port)
	M1	To #1 rotor
	M2	To #2 rotor
	M3	To #3 rotor
	M4	To #4 rotor
	M5	To #5 rotor
	M6	To #6 rotor
	F1	To gimbal roll servo
	F2	To gimbal pitch servo
	LED	LED port, for LED wire connection from Versatile Unit
	EXP.	GPS port, for GPS module wire connection. (In three-pin ports, pins near the nicks are signal pins.)
Versatile Unit		
V-SEN	V-SEN port: To the X3 port of the main controller, for monitoring battery voltage and supplying power	
	<ul style="list-style-type: none"> Orange wire (signal wire) output: $\pm 3.3V$ Red wire (power wire) output: 3A@5V 	
LED	LED wire, to LED port of the main controller.	
	USB port: PC connection for configuration and firmware upgrades.	
Optional GPS & Compass		
	Connect to the EXP. port.	





V1 Specification

General	
Built-In Functions	<ul style="list-style-type: none">● Three Modes of Autopilot● Enhanced Fail Safe● Low Voltage Protection● S-Bus/ S-Bus2 Receiver Support● PPM Receiver Support● 2-axle Gimbal Support
Peripheral	
Supported Multi-rotor	<ul style="list-style-type: none">● Quad-rotor I4, X4;● Hexa-rotor I 6, X6, IY6, Y6.● Octo-rotor I8, V8, X8 (Upgrade the MC Firmware to V3.10 or above)
Supported ESC output	400Hz refresh frequency.
Recommended Transmitter	PCM or 2.4GHz with a minimum 4 channels.
Assistant Software System Requirement	Windows XP SP3; Windows 7
Electrical & Mechanical	
Working Voltage Range	<ul style="list-style-type: none">● MC: 4.8V ~ 5.5 V● VU Input: 7.2V ~ 26.0 V (recommend 2S ~ 6S LiPo) Output(V-SEN port red wire): 3A@5V Output(V-SEN port red wire)burst current:7.5A
Power Consumption	<ul style="list-style-type: none">● MAX: 1.5W(0.3A@5V)● Normal: 0.6W(0.12A@5V)
Operating Temperature	-10°C ~ 50°C(14F ~122F)
Weight	<ul style="list-style-type: none">● MC: 25g● GPS: 21.3g● VU: 20g
Dimensions	<ul style="list-style-type: none">● MC: 45.5mm × 31.5mm × 18.5mm● GPS & Compass: 46mm (diameter) × 9mm● VU: 32.2mm × 21.1mm × 7.7mm
Flight Performance (can be effected by mechanical performance and payloads)	
Hovering Accuracy (GPS Mode)	<ul style="list-style-type: none">● Vertical: ± 0.8m● Horizontal: ± 2.5m
Max Yaw Angular Velocity	200° /s
Max Tilt Angle	45°
Max Ascent / Descent Speed	6m/s

FAQ

Abnormal LED Indication List

During the Checking Procedure, if abnormal LED Indicator occurs or even the system cannot work normally, please refer to the following list and aids troubleshooting.

- (1) "System initializing and self-checking LED flashes" are not correct ( Red LED appears in the last four green flashes). The autopilot system works abnormally. Please contact your dealer.
- (2) LED blinks Yellow 4 times quickly (). The system is warming up. You cannot start the motors until the 4 rapid yellow flashes disappear. If the warm up waiting is longer than 2 minutes, please power off for 5 minutes, cold start, and then connect the assistant software, enter the "Tools" -> IMU calibration, carry out the Advanced calibration.
- (3) After the system start and self-checking has finished, if the LED blinks Red, Green and Yellow () continually. Sensor error is too big. Please connect the assistant software, enter the "Tools" -> IMU calibration, carry out calibration.
- (4) At the first motors start, the system will check the sensors Bias and you are asked to keep the aircraft stationary (no need of horizontal level). If you cannot start the motors and the LED blinks Green 6 times quickly (), it means that the sensor error is too big. Please connect the assistant software, enter the "Tools" -> IMU calibration, carry out basic calibration.



Note: after the first successful motors start, this checking will be disabled and it is no need any more to keep the aircraft stationary during starting motors.
- (5) The system blinks Red LED quickly during flying. Low-voltage protection is triggered. Please land the aircraft ASAP.
- (6) The system blinks Yellow LED quickly during flying. FailSafe Mode is triggered. Pay attention that there is no tall buildings and trees to block your aircraft during go-home.
- (7) The LED blinks Red and Yellow alternately (). Compass error is too big.
 - a) There may be a ferromagnetic substance close to the Phantom. Lift the aircraft up about 1m from the ground, if there is no Red and Yellow flashing, then it will not affect the flight.
 - b) Otherwise, re-calibrate the compass.
 - c) If re-calibration does not work, please connect to the Assistant Software, select the "Tools" and follow the tips to carry out the required operation.

Fix the TBE (Toilet Bowl Effect) Problem

When flying in GPS ATTI Mode and the compass calibration has been done correctly, should you find the aircraft rotating (Toilet bowl effect), or drifting when hovering. Please check the GPS module mounting orientation and then

re-do the compass calibration. Carry out the following procedure to re-mount the GPS module.

In the following diagram (view from the top), the aircraft can appear to be rotating in both clockwise and counter-clockwise direction, please re-mount the GPS module correspondingly.

 is the rotating direction of aircraft,
  is the nose direction of aircraft,
  is the arrow direction on the GPS module, θ is the offset angle for GPS re-mounting (about 10-30°)

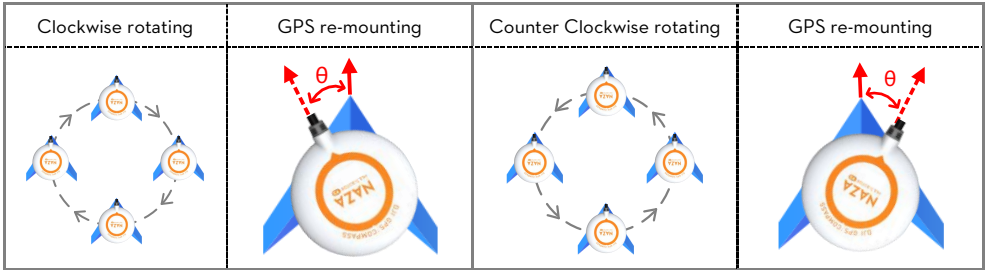

Should you find the multi-rotor does not track straight in forward flight.

Please carry out several more courses, the system will fix it automatically.

Motors Start failure caused by TX stick(s) mid point error too big

If the TX stick(s) mid point error is too big, Motors Start will fail when you execute the Combination Stick Commands (CSC) and lead to the aircraft will not takeoff.. And the LED will blink Red four times per second continually to warn you.

TX stick(s) mid point error too big can be caused by the following reasons:

- (1) There is TX stick (except the throttle stick) not at center when power on the autopilot system.
- (2) The TX sticks has been trimmed, which leads to the large deviation of mid point. For example, the SUB-TRIM has been adjusted for Futaba transmitter.
- (3) The TX stick(s) travel has larger asymmetry.

For the reason (1), please put all TX sticks at the mid point, and then power cycle the autopilot system to re-record the mid point. If the problem continues, that can be caused by the reason (2) or reason (3), you need to adjust the output range of your TX, and then use the Assistant Software to redo the TX calibration. Please carry out the following procedures.

- (1) Connect to the Assistant software, click Basic-> R/C-> Command Sticks Calibration, and push all TX sticks throughout their complete travel range to see if any stick cannot reach its largest position.
- (2) Adjust the largest travel of TX stick until the cursor on the Assistant software can reach both end positions, according to your TX manual.
- (3) Power cycle the autopilot system, note that power cycle is required.
- (4) Redo the TX calibration according to the Assistant software.

Attitude Controllable When One Motor Output is Failed

For Hexa-rotor, including Hexa-rotor I, Hexa-rotor V, Hexa-rotor IY and Hexa-rotor Y, aircraft is attitude controllable when one motor output is failed.

The NAZA-M can still control the attitude of the Hexa-rotor for a safe landing when one motor output of the Hexa-rotor has failed, for example, one motor is stopped or one propeller is broken, etc.

The control mode of NAZA-M should be in Atti. Mode or GPS Atti. Mode. The aircraft will rotate, due to an imbalance of torque; however, it can still be controlled by the Transmitter.

Select Course lock or home lock mode for flying the aircraft into a safe area to land when the aircraft is far away or the attitude can't be recognized. Even when the multi rotor is rotating, using Course lock or home lock mode will allow you to move the multi rotor in the corresponding Transmitter stick direction.

When used with other DJI products

The NAZA-M system communicates with other DJI products (e.g. H3-2D gimbal, BTU module, iOSD mini and iOSD Mark II) via the CAN-Bus port (CAN) of the NAZA PMU V2. You can plug new DJI products into any spare CAN-Bus port, since CAN-Bus ports on NAZA-M, CAN HUB, GCU, iOSD mini, iOSD Mark II and 2.4G Bluetooth Datalink are the same for the communications.

When there are not enough CAN-Bus ports for additional DJI products, then a DJI CAN HUB module is recommended. The following diagram is for your connection reference.

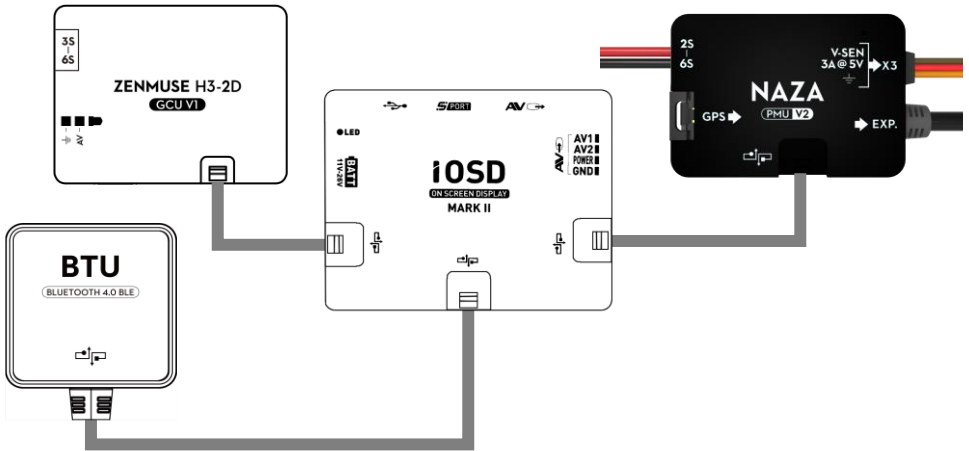

Fig.1 Used with iOSD Mark II

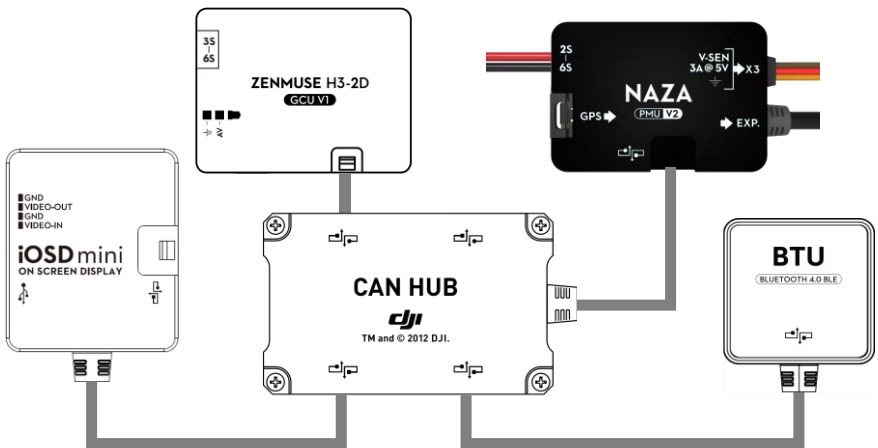

Fig.2 Used with CAN HUB

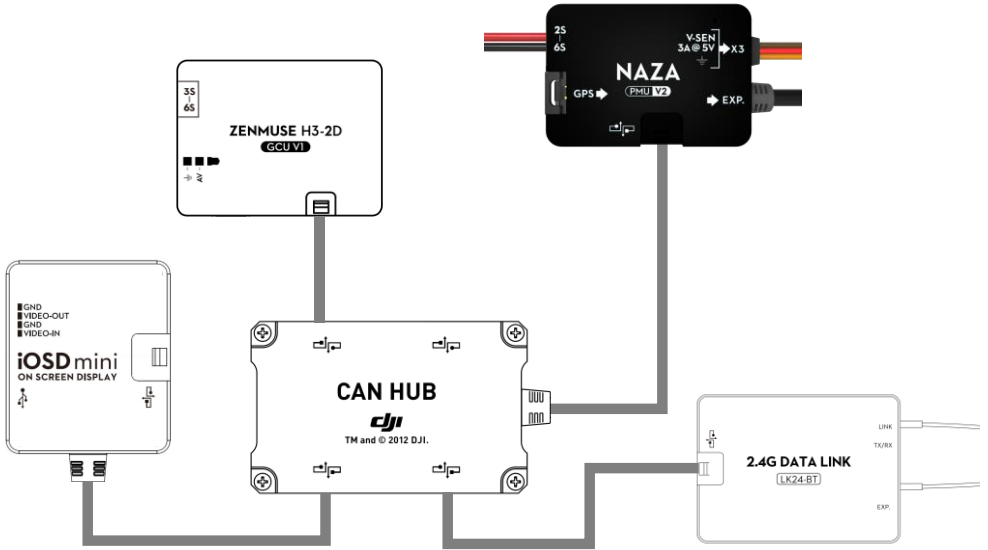

Fig.3 Use a CAN HUB to connect the 2.4G Bluetooth Datalink



- (1) Users can use the NM Assistant on the mobile device when a BTU module is connecting with the Ground end of the 2.4G Bluetooth Datalink (No need to connect another BTU module to the Flight control system).

SMART FLIGHT BATTERY

Safety Guidelines

SMART FLIGHT BATTERIE

Nutzungshinweise

BATTERIES INTELLIGENTES

Guide d'Utilisation

飞行器智能电池

安全使用指引

マルチコプター電池

安全使用ガイド

V1.0

2014.07



English

Battery Use

- **Never use non-DJI batteries.** Go to www.DJI.com to purchase new batteries. DJI takes no responsibility for any accidents caused by non-DJI batteries.
- Never use or charge a swollen, leaky or damaged battery. If so, contact DJI or its designated dealers for further assistance.
- Do NOT install the battery into the battery compartment on the Phantom when turned on. Turn off the battery before installing it or removing it from the Phantom. **Never install or remove the battery from the Phantom when it is turned on.**
- The battery should be used in temperatures from -20°C to 40°C. Use of the battery above 50°C can lead to a fire or explosion. Use of battery below -20°C can lead to permanent damage.
- Do not use the battery in strong electrostatic or electromagnetic environments. Otherwise, the battery control board may malfunction and a **serious accident may happen during flight.**
- Never disassemble or pierce the battery in any way, or the battery may catch fire or explode.
- Electrolytes in the battery are **highly corrosive**. If any electrolytes splash onto your skin or eyes, immediately wash the affected area with fresh running water for at least 15 minutes then see a doctor immediately.
- Check the condition of the battery if it falls out of the Phantom. Make sure the battery is **NOT damaged or leaking** before putting it back to the Phantom.
- Land the Phantom immediately when the low battery level warning activates in the DJI VISION App.
- **Do not drop the battery into water.** If the inside of the battery comes into contact with water, chemical decomposition may occur, potentially resulting the battery catching on fire, and may even lead to an explosion. If the battery falls into water with the Phantom during flight, take it out immediately and put it in a safe and open area. Maintain a far distance from the battery until it is completely dry. **Never use the battery again, and dispose of the battery properly as described in Battery Disposal below.**
- Put out any battery fire using sand or a dry powder fire extinguisher. Never use water to put out a battery fire.

Charging the Battery

- Batteries **must be charged using a DJI approved adapter**. DJI takes no responsibility if the battery is charged using a non-DJI charger. Never leave the battery unattended during charging. Do not charge the battery near flammable materials or on flammable surfaces such as carpet or wood.
- Do not charge battery immediately after flight, because the battery temperature may be too high. Do not charge the battery until it cools down to near room temperature. Charging battery outside of the temperature range of 0°C-40°C may lead to leakage, overheating, or battery damage.
- Charge and discharge the battery completely once every 20 charge/discharge cycles. Discharge the battery until there is less than 8% power or until it can no longer be turned on, then recharge it to the maximum capacity. This power cycling procedure will optimize the battery life.

Battery Storage

- Do not leave the battery near heat sources such as a furnace or heater. The ideal storage temperature is 0°C-21°C.
- Keep the battery dry. Never drop the battery into water.
- Do not drop, strike, impale, or manually short-circuit the battery.
- Keep the battery away from metal objects such as necklaces and hairpins.
- Discharge the battery to 30%-50% of the battery level if it will not be used for 7 days or more. This can greatly extend the battery life.

Battery Disposal

- Dispose of the battery into specific recycling boxes only after a complete discharge. Do not place the battery into regular rubbish bins. Strictly follow your local disposal and recycling regulations of batteries.
- If the power on/off button of the smart battery is disabled and the battery cannot be fully discharged, please contact a professional battery disposal/recycling agent for further assistance.

Deutsch

58. Batterienutzung

Benutzen Sie ausschließlich originale DJI

Batterien. Gehen Sie auf www.DJI.com, um neue Batterien zu erwerben. Für Schäden, die durch die Verwendung von Nicht-Originalteilen und Zubehör entstehen, ist jedwede Haftung des Herstellers ausgeschlossen.

- Benutzen oder Laden Sie niemals eine angeschwollene, undichte oder beschädigte Batterie. Kontaktieren Sie gegebenenfalls DJI oder unsere ausgewiesenen Händler für weitere Informationen.
- Setzen Sie **NIEMALS** die Batterie in das Batteriefach des Phantom ein, während die Batterie eingeschaltet ist. Schalten Sie die Batterie aus, bevor Sie diese in das Batteriefach einsetzen oder vom Phantom entfernen. **Setzen Sie niemals die Batterie ins Batteriefach ein oder entfernen sie, wenn diese eingeschaltet ist.**
- Die Batterie sollte nur in einem Temperaturbereich von -20°C bis 40°C benutzt werden. Der Gebrauch der Batterie bei über 50°C kann zu Feuer oder einer Explosion führen. Die Verwendung bei unter -20°C kann zu dauerhaften Schäden führen.
- Verwenden Sie die Batterie nie in starken elektrostatistischen oder elektromagnetischen Umfeldern. Das Batterie Control Board könnte versagen und **ein schwerer Unfall während des Fluges passieren.**
- Bauen Sie die Batterie niemals auseinander oder durchbohren Sie diese, die Batterie könnte Feuer fangen oder explodieren.
- Die Akkumulatorsäure in der Batterie ist **stark korrosiv**. Säurespritzer im Auge oder auf der Haut sofort unter frischem, laufendem Wasser aus- bzw. abspülen und anschließend sofort einen Arzt aufsuchen.
- Überprüfen Sie den Zustand der Batterie, falls diese aus dem Phantom herausfällt. Stellen Sie sicher, dass die Batterie **NICHT beschädigt ist oder ausläuft**, bevor Sie diese zurück in den Phantom stecken.
- Laden Sie den Phantom umgehend, sobald die Batteriewarnung in Ihrer DJI VISION App erscheint.
- **Lassen Sie die Batterie niemals in Wasser fallen.** Wenn das Innere der Batterie mit Wasser in Kontakt kommt, könnte eine chemische Zersetzung ausgelöst werden, durch die die Batterie möglicherweise Feuer fängt oder sogar explodiert. Falls die Batterie während des Fluges mit dem Phantom in Wasser fällt, entfernen Sie diese unverzüglich aus dem Fluggerät und legen diese in eine sichere und

offene Umgebung. Halten Sie großen Abstand zu der Batterie bis diese komplett getrocknet ist. **Benutzen Sie die Batterie niemals erneut und entsorgen Sie die Batterie sachgerecht, wie unten in dem Kapitel Entsorgen der Flugbatterie beschrieben.**

- Löschen Sie jeden Batteriebrand mit Hilfe von Sand oder einem Pulverlöscher. Löschen Sie einen Batteriebrand niemals mit Wasser.

Aufladen der Flugbatterie

- **Batterien müssen mit einem von DJI zugelassenen Adapter geladen werden.** DJI übernimmt keine Haftung für Batterien, die mit einem nicht von DJI autorisierten Ladegerät geladen wurden. Lassen Sie die Batterie während des Ladevorgangs niemals unbeaufsichtigt. Laden Sie die Batterie nicht in der Nähe von entflammaren Materialien oder Oberflächen wie Teppich oder Holz.
- Laden Sie die Batterie nicht direkt nach dem Flug, die Temperatur der Batterie könnte zu hoch sein. Laden Sie die Batterie erst, sobald sie auf mindestens Raumtemperatur abgekühlt ist. Das Laden der Batterie außerhalb des Temperaturbereichs von 0°C - 40°C kann zu Auslaufen, Überhitzen oder einem Schaden an der Batterie führen.
- Laden und Entladen Sie die Batterie einmal vollständig alle 20 Lade-/Entladevorgänge. Entladen Sie die Batterie bis auf unter 8% bis sie nicht mehr eingeschaltet werden kann, dann laden Sie diese bis zum Maximum ihrer Kapazität auf. Das beschriebene Verfahren optimiert die Lebensdauer Ihrer Batterie.

Lagerung der Flugbatterie

- Lassen Sie die Batterie nicht in der Nähe von Hitzequellen wie einem Ofen oder Heizkörper. Die ideale Lagerungstemperatur liegt zwischen 0°C - 21°C.
- Die Batterie ist sauber und trocken zu lagern. Lassen Sie die Batterie niemals in Wasser fallen.
- Lassen Sie die Batterie nicht fallen, spießen Sie diese nicht auf, schließen Sie sie nicht manuell kurz und wirken Sie nicht mit Gewalt auf die Batterie ein.
- Halten Sie die Batterie fern von Metallobjekten wie Ketten und Haarnadeln.
- Entladen Sie die Batterie bis auf 30% - 50%, falls Sie diese für 7 Tage oder länger nicht benutzen.

Dies kann die Lebensdauer Ihrer Batterie stark verlängern.

Entsorgung der Flugbatterie

- Entsorgen Sie die Batterie, nur nachdem Sie komplett entladen wurde, in speziellen Recycling Tonnen. Werfen Sie die Batterie nicht in die normale Mülltonne. Beachten und befolgen Sie unbedingt die kommunalen Entsorgungs- und Recyclingvorschriften für Batterien.
- Falls der On/Off Knopf der Batterie nicht funktioniert und die Batterie nicht vollständig entladen werden kann, kontaktieren Sie bitte eine professionelle Entsorgungs-/Recyclingfirma.

Français

Utilisation de la Batterie

- **N'utilisez jamais de batterie autre que d'origine.** Rendez-vous sur www.DJI.com pour acheter de nouvelles batteries. La responsabilité de DJI ne pourrait être engagée pour tout accident résultant de l'utilisation de batteries non-DJI.
- N'utilisez ni ne chargez jamais de batterie déformée, qui suinte ou qui est endommagée. Si vous constatez un problème contactez DJI ou ses revendeurs agréés pour recevoir l'assistance nécessaire.
- N'installez PAS la batterie dans le compartiment du Phantom si elle est allumée. Éteignez la batterie avant de l'installer ou de la retirer du Phantom. N'installez ou ne retirez jamais la batterie du Phantom lorsqu'il est allumé.
- **La batterie peut être utilisée sous des températures allant de -20°C à 40°C.** Utiliser la batterie au-delà de 50°C peut causer un incendie ou une explosion. L'utiliser en deçà de -20°C peut causer un dommage irréparable à la batterie.
- **N'utilisez pas la batterie dans un environnement électrostatique ou électromagnétique important.** Sinon, l'unité de contrôle de la batterie pourrait mal fonctionner et un sérieux accident pourrait survenir pendant le vol.
- **Ne désassemblez ou ne percez jamais la batterie d'aucune manière, ou celle-ci pourrait prendre feu ou exploser.**
- L'électrolyte dans la batterie est très corrosif. Si de l'électrolyte éclabousse votre peau ou vos

yeux, rincez immédiatement la zone affectée à l'eau fraîche courante pendant au moins 15 minutes puis consultez immédiatement un docteur.

- **Vérifiez l'état de la batterie si elle tombe du Phantom. Vérifiez que la batterie n'est PAS endommagée ou suintante avant de la remettre dans le Phantom.**
- **Faites atterrir le Phantom immédiatement** dès que l'alerte de faible batterie se déclenche dans l'App DJI VISION.
- **N'immergez pas la batterie. Si l'intérieur de la batterie entre en contact avec de l'eau une réaction chimique peut se produire, résultant potentiellement en un incendie ou même en l'explosion de la batterie.** Si la batterie tombe à l'eau avec le Phantom lors d'un vol retirez-la immédiatement et mettez-la à l'abri dans un endroit sécurisé et ouvert. Restez à bonne distance de la batterie jusqu'à ce qu'elle soit entièrement sèche. Ne la réutilisez jamais et déposez-la correctement comme décrit plus bas dans le paragraphe sur le Recyclage des Batteries. **Eteignez une batterie en flammes en utilisant du sable ou un extincteur à poudre sèche. N'utilisez jamais d'eau pour éteindre une batterie en feu.**

Charge de la Batterie

- **Les batteries doivent être chargées à l'aide d'un chargeur approuvé par DJI.** La responsabilité de DJI ne peut être engagée si la batterie est chargée avec un autre chargeur que celui proposé par DJI. Ne laissez jamais la batterie sans surveillance durant la charge. Ne chargez pas la batterie près d'une source de chaleur, d'un matériau inflammable ou sur une surface inflammable comme un tapis ou du parquet.
- **Ne chargez pas votre batterie immédiatement après un vol car la température pourrait être trop élevée.** Ne chargez la batterie que lorsque celle-ci aura atteint la température ambiante. Charger la batterie hors de la plage de température comprise entre 0°C et 0°C peut entraîner une fuite, une surchauffe ou une panne de la batterie.
- Chargez et déchargez complètement la batterie tous les cycles de 20 charges/décharges. Déchargez la batterie jusqu'à ce qu'il reste moins de 8% de charge ou jusqu'à ce que la batterie ne puisse plus être allumée puis rechargez-la jusqu'à sa capacité maximale.

Cette procédure de charge cyclique optimisera la durée de vie de votre batterie.

Stockage des Batteries

- Ne laissez jamais la batterie près d'une source de chaleur comme un radiateur ou un poêle. La température idéale de stockage est de 0°C -21°C.
- Maintenez la batterie bien sèche. Ne l'immergez jamais dans un liquide.
- Ne faites pas tomber ni ne cognez la batterie, ne la percez pas, ne provoquez pas volontairement de court-circuit sur la batterie.
- Gardez la batterie éloignée de petits objets métalliques tels que des épingles à cheveux, des trombones, des petits bijoux.
- Déchargez la batterie aux alentours de 30%-50% de son niveau de charge si vous ne l'utilisez pas pendant une semaine ou plus. Ceci augmentera de manière conséquente la durée de vie de votre batterie.

Recyclage des Batteries

- Mettez votre batterie dans une boîte de recyclage adaptée uniquement après l'avoir complètement déchargée. Ne mettez pas votre batterie avec les ordures ménagères. Suivez scrupuleusement les consignes locales précises en matière de recyclage des piles et batteries.
- Si le bouton ON/OFF de la batterie intelligente est inopérant et que la batterie ne peut être complètement déchargée, veuillez s'il vous plaît contacter un Professionnel du recyclage afin d'obtenir l'assistance nécessaire.

中文

使用

- 严禁使用非大疆官方提供的电池。如需更换，请到大疆官网查询。因使用非大疆官方提供的电池而引发的电池事故、飞行故障，大疆概不负责。
- 严禁使用鼓包的、漏液的、包装破损的电池。如有以上情况发生，请联系大疆或者其指定代理商做进一步处理。
- 在将电池安装或者拔出于飞行器之前，请保持电池的电源关闭。请勿在电池电源打开的状态下，拔插电池。
- 电池应在室温为 -20°C 至 40°C 之间使用。温度过高，会引起电池着火，甚至爆炸。温度过低，电池寿命会受到严重损害。
- 禁止在强静电或者磁场环境中使用电池。否则，

电池保护板会失灵，导致飞行器发生严重故障。

- 禁止以任何方式拆解或用尖利物体刺破电池。否则，会引起电池着火甚至爆炸。
- 电池内部液体有强腐蚀性。如有泄露，请远离。如有溅射到人体皮肤或者眼睛里，请立即用清水冲洗至少 15 分钟，并立即就医。
- 若电池从飞行器中摔落，再次使用前，务必确保电池外观无损，无破损、无漏液等问题。
- 若飞机进入电量低报警模式，应尽快降落并停止飞行，更换新电池或者对电池进行充电。
- 请勿将电池浸入水中或将其弄湿。电池内部接触到水后可能会发生分解反应，引发电池自燃，甚至可能引发爆炸。如果电池在 Phantom 飞行过程中或其它情况下意外坠入水中，请立即拔出电池并将其置于安全的开阔区域，这时应远离电池直至电池完全晾干。晾干的电池不得再次使用，应该按照本文的废弃方法妥善处理。
- 若电池发生起火，应立即采用“窒息灭火法”，如使用沙子或固体或干粉灭火器进行灭火。严禁用水来灭火。

充电

- 智能电池必须使用 DJI 官方提供的专用充电器或车载充电器进行充电。对于使用非 DJI 官方提供的充电器进行充电所造成的一切后果，DJI 将不予负责。
- 请留意充电过程以防发生意外。充电时请将电池和充电器放置在水泥地面等周围无易燃、可燃物的地面。
- 禁止在飞行器飞行结束后，立刻对电池进行充电。此时，电池处于高温状态，强制充电会对电池寿命造成严重损害。建议待电池降至室温，再对电池进行充电。理想的充电环境（0-40°C）可大幅度延长电池的使用寿命。
- 电池每经过约 20 次充放电后，需要进行一次完整的放电和充电过程（将电池充满电，然后放电至电量为 8% 以下或电池自动关闭，再充满电）以保证电池工作在最佳状态。

储存

- 禁止将电池放在靠近热源的地方，比如火源或加热炉。智能电池的理想保存温度为 0-21°C。
- 存放电池的环境应保持干燥。请勿将电池置于水中或者可能会漏水的地方。
- 禁止机械撞击电池、碾压、坠落、人为短路、刺穿电池。
- 禁止将电池与金属项链、发夹或者其他金属物体一起贮存或运输。
- 超过 7 天不使用电池，请将电池放电至 30%-50% 电量存放，可大大延长电池的使用寿命。

廃棄

- 務必将電池彻底放完后，才将電池置于指定的電池回收箱中。電池是危險化學品，嚴禁廢置于普通垃圾箱。相關細節，請遵循當地電池回收和棄置的法律法規。
- 如電池因為電源開關失靈而無法完成彻底放電，請勿將電池直接棄置于電池回收箱，應聯系專業電池回收公司做進一步的處理。

日本語

使用

- 非 DJI 社製の電池を使用することによって発生する事故は DJI 社一切の責任を負いません。
- 包装破損、傷ついた電池を使用することが禁じます。上記したものが発生した場合、DJI 社或いは購入先の代理店までご連絡ください。
- 電池の取り付けや取り外しの前は、必ず電源をオフにしてください。電源をオンにしたままで、操作しないでください。
- 電池は温度 -20℃ から 40℃ の間で使用してください。温度が高くなると、火事を引き起こします。低くなると、電池の寿命が短縮します。
- 強い静電気または磁気が起こる環境での電池の使用を禁止します。バッテリー保護基板の機能が失い、飛行器の故障につながる可能性があります。
- いかなる方法で電池を解体することは禁じます。火事や爆発事故が発生する原因とみられます。
- 電池内部の液体は腐食性が強いです。液体が漏れると、離れてください。皮膚や目に入った場合、すぐに 15 分以上水で洗い流し、速やかに医師の診察を受けてください。
- 飛行中に電池が墜落したら、再使用する前に電池の外観が破損したかどうかを確認してください。
- 飛行中に低電量アラームがなりましたら、すぐ安全地に着陸して、電池を交換するか充電してください。
- 電池を水に入れてください。電池内部は水が入ると化学反応が起こり、自然発火して

爆発する可能性があります。飛行中、機体が水に落ちた場合、直ちに電池を外して安全地で乾燥してください。乾燥した電池を再利用することは禁じます。本章の廃棄方法で処理してください。

- 電池が発火したら、砂や消火器で消火してください。水での消火を避けてください。

充電について

- 必ず DJI 社の充電器或いはカーチャージャーで充電してください。非 DJI 社提供した充電器を使用することで起こった事故など、DJI 社は一切の責任を負いません。
- 充電中の充電状況を常に確認してください。充電時、可燃物の上に置かないでください。
- 飛行が終わった後、電池はまだ高温状態の為、充電してはいけません。電池の寿命が短縮します。推奨の充電温度は 0 ~ 40 度です。
- 電池のベスト状態を確保する為、20 回充電した後、一回完全充電してください。

保管について

- 発熱源の近くで使用したり、保管したりしないでください。0 - 21℃ の環境での保管を推奨します。
- 乾燥した環境での保管してください。水中や水漏れの場所に置かないでください。
- バッテリーに衝撃加えたり、墜落させたり、人為的にショートさせたりしないでください。
- 金属物体或いは金属アクセサリと一緒に保管したり運送したりしないでください。
- 使用しない期間は 7 日間を超える場合はバッテリー残量を 30% - 50% の状態にすることでバッテリーの寿命を延ばすことが可能です。

破棄について

- バッテリーは化学品の為、破棄するときは火災の原因とならないように、完全に放電を行ってから破棄してください。破棄方法は各エリアの条例を守ってください。
- バッテリーの電源の故障による放電できない場合は回収箱に入れずに、業者に連絡のうえ正しく処理を行ってください。

PHANTOM

[Overview](#)[Features](#)[Specs](#)[Videos](#)[Downloads](#)[FAQ](#)[Wiki](#)[Dealers](#)[Buy Now](#)

PHANTOM

READY TO FLY AERIAL FILMING
MULTIROTOR SYSTEM WITH GOPRO MOUNT

Phantom 1 Features

- Attractive and Highly Integrated Design
- Ready to Fly Design
- Contains Remote Control Unit. (Just add 4 x AA batteries)
- Stable, Agile Performance, Easy to Fly



- Two Flight Control Modes, Including Position Hold
- Intelligent Orientation Control (IOC)
- Failsafe & auto go home/landing
- Low voltage protection
- Maximum flight speed 10 m/s
- High Intensity LED Lights, To Aid Orientation During Flight
- GOPRO CAMERA MOUNT (CAMERA NOT INCLUDED)
- 10 to 15 minutes of flight time

[Learn More](#)



[About DJI](#) | [Contact DJI](#) | [News](#) | [Media Coverage](#) | [Showcase](#) | [Careers](#) | [DJI Wiki](#) | [After-sales Service Policies](#) | [Website Feedback](#) | [DJI Developer](#)

dji THE FUTURE OF POSSIBLE Copyright © 2015 DJI All Rights Reserved. [Privacy Policy](#) [Terms of Use](#)



PHANTOM

Top training platform for new pilots.
Easy to setup, ready to fly.



Flexible, allowing you to fly the way you want
under different control modes.

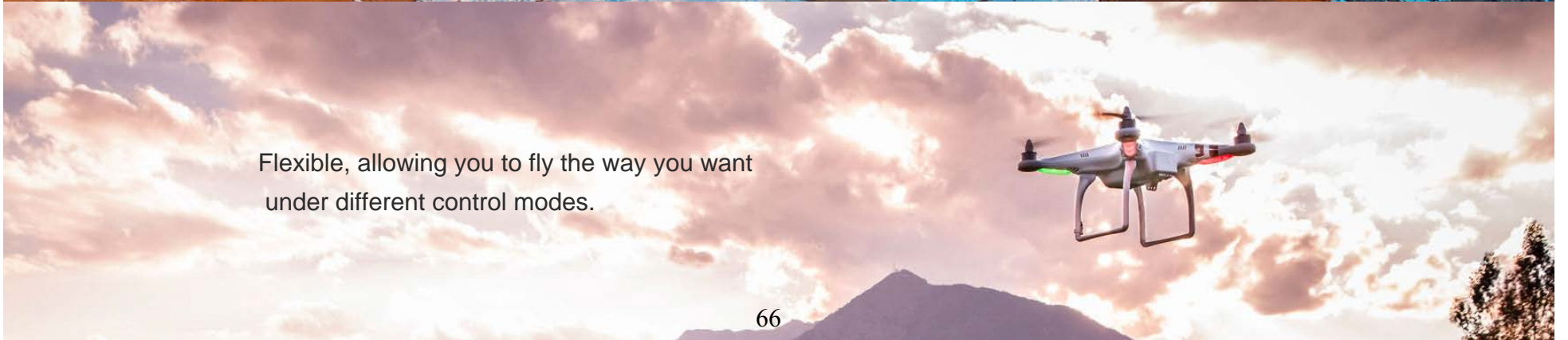



Classic flight system for those new
to aerial photography.

PHANTOM

[Overview](#)[Features](#)[Specs](#)[Videos](#)[Downloads](#)[FAQ](#)[Wiki](#)[Dealers](#)[Buy Now](#)

Size and Weight

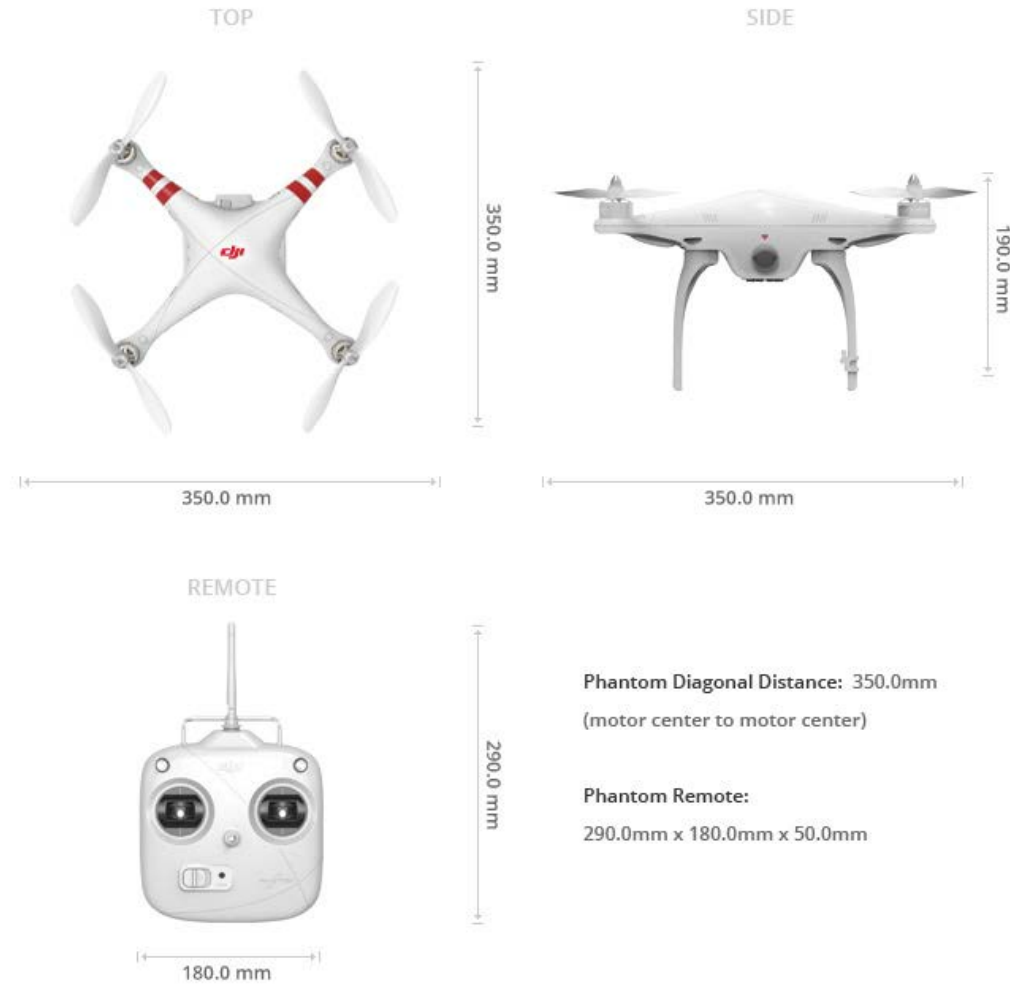

Power Consumption	3.12W
Take-Off Weight	<1200g
Hovering Accuracy (GPS Mode)	Vertical: 0.8m Horizontal: 2.5m
Max Yaw Angular Velocity	200°/s
Max Tilt Angle	45°
Max Ascent / Descent Speed	6m/s
Max Flight Velocity	10m/s
Diagonal Distance (Motor Center To Motor Center)	350mm
Phantom Prop Guard	Weight(Single):18.7g Size(Single): Angle(155.0°) Radius(112.32mm) Whole Size with Four Prop Guards: 575.5mm

ESC Sound Introduction

Ready	♪1234567
Throttle Stick Is Not At Bottom	BBBBBB...
Input Signal Abnormal	B——B——B...
Input Voltage Abnormal	BB—BB—BB—BB...

Charger & Battery Parameters

Charger AC Input	100-240V
Charge Current	1A/2A/3A
Current Drain For Balancing	200mA

Power	69	20W
--------------	----	-----

	Battery Type	LiPo
TX Parameters	Working Frequency	2.4GHz ISM
	Control Channels	7 Channels
	Communication Distance	1000m
	Receiver Sensitivity 1%PER	-100dBm
	Power Consumption Of TX	20dBm
	Working Current /Voltage	52 mA@6V
	AA Battery	4 Required

PHANTOM 2

[Overview](#)[Features](#)[No Fly Zones](#)[Specs](#)[Videos](#)[Downloads](#)[Wiki](#)[Dealers](#)[Buy Now](#)

PHANTOM 2

THE SPIRIT OF FLIGHT

Additional Accessories:

- [Zenmuse GoPro® Gimbal \(for Stable Aerial Footage\)](#)
- [iPad Ground Station \(for Planning Precision Flights\)](#)
- [DJI Lightbridge \(for HD FPV Flight\)](#)
- [iOSD \(for Real-Time Flight Data Display\)](#)





Introduces The Phantom 2



Zenmuse H3-3D on Phantom Stability Demo



How to install
the Zenmuse H3-2D on Phantom 2



How to install
the Zenmuse H3-3D on the New Phantom 2



CREATE
ASTONISHING



AERIALS

The Phantom 2 is unbelievably easy to fly. Combined with smooth, stabilized footage from the H3-2D, H3-3D or H4-3D gimbal, aerial cinematography and videography has never been easier. It's light, rugged and perfect for travel.

Requires Zenmuse H3-2D, H3-3D or H4-3D, video downlink and monitor.

REAL FLIGHT AT YOUR FINGERTIPS

See what the camera sees and lose yourself in picture quality so good it will feel like you're in the sky yourself.

Requires DJI Lightbridge, iOSD mini or iOSD MK II, video downlink and monitor.



DJI LIGHTBRIDGE SOLUTION



The DJI Lightbridge 2.4G full HD digital video downlink features a native OSD system that needs no additional equipment, for an all-in-one FPV experience. Once connected, you can control your flight controller through its built-in 2.4G remote control link or DJI 5.8G remote control.

A white DJI drone with a camera is flying over a city at sunset. In the foreground, a black iOSD MARK II device is shown. To the right, a tablet displays a detailed OSD interface with various flight parameters.

DJI IOSD SOLUTION

Install an iOSD MK II or iOSD mini to see real-time flight data.

Parameter	Value
Battery Voltage	12.0 V 94%
Altitude	45-179
Distance	45-179
Roll (R)	0°
Pitch (P)	0°
Yaw (Y)	0°
Roll Rate (R)	0.0 M/S
Pitch Rate (P)	0.0 M/S
Yaw Rate (Y)	0.0 M/S
Roll (R)	0°
Pitch (P)	0°
Yaw (Y)	0°
Roll Rate (R)	0.0 M/S
Pitch Rate (P)	0.0 M/S
Yaw Rate (Y)	0.0 M/S
Roll (R)	0°
Pitch (P)	0°
Yaw (Y)	0°
Roll Rate (R)	0.0 M/S
Pitch Rate (P)	0.0 M/S
Yaw Rate (Y)	0.0 M/S



UNBELIEVABLE INTELLIGENCE

Program your flight path from an iPad with the 16 waypoint Ground Station system, to shoot with more precision than ever.
(Requires DJI 2.4G Bluetooth(R) Datalink.)

LIGHTWEIGHT, EASY TO CARRY



WEIGHT
1000g



DIMENSIONS (CM)
29 x 29 x 18



FLIGHT TIME
25mins



[More Features](#)

PHANTOM Your Flying Camera

[learn more](#)

COMPARE PHANTOMS



[Compare Now](#)

DJI OFFICIAL STORE



Buy from the DJI Official Store

[Buy Now](#)

DJI AUTHORIZED DEALERS



Buy from DJI authorized dealers

[Find a local dealer](#)

HELP AND SUPPORT



[Wiki](#)

[Downloads](#)

[Support](#)

[After-sales Service Policies](#)

[About DJI](#) | [Contact DJI](#) | [News](#) | [Media Coverage](#) | [Showcase](#) | [Careers](#) | [DJI Wiki](#) | [After-sales Service Policies](#) | [Website Feedback](#) | [DJI Developer](#)

dji THE FUTURE OF POSSIBLE Copyright © 2015 DJI All Rights Reserved. [Privacy Policy](#) [Terms of Use](#)



PHANTOM 2

[Overview](#)[Features](#)[No Fly Zones](#)[Specs](#)[Videos](#)[Downloads](#)[Wiki](#)[Dealers](#)[Buy Now](#)

Body



Remote Control



With H3-3D

click and drag

Highlights





AERIALS

The Phantom 2 is unbelievably easy to fly. Combined with smooth, stabilized footage from the H3-2D, H3-3D or H4-3D gimbal, aerial cinematography and videography has never been easier. It's light, rugged and perfect for travel.

Requires Zenmuse H3-2D, H3-3D or H4-3D, video downlink and monitor.

REAL FLIGHT AT YOUR FINGERTIPS

See what the camera sees and lose yourself in picture quality so good it will feel like you're in the sky yourself.

Requires DJI Lightbridge, iOSD mini or iOSD MK II, video downlink and monitor.



DJI LIGHTBRIDGE SOLUTION



The DJI Lightbridge 2.4G full HD digital video downlink features a native OSD system that needs no additional equipment, for an all-in-one FPV experience. Once connected, you can control your flight controller through its built-in 2.4G remote control link or DJI 5.8G remote control.



A composite image for the DJI iOSD solution. On the left, a white DJI drone with red and white stripes on its arms is flying over a cityscape at sunset. In the center, the black iOSD MARK II hardware is shown. On the right, a tablet displays a detailed OSD interface with various flight parameters: 12.0V 94% battery, P: 0°, V: 0.0m/s, R: 0°, 45-179 altitude, 15m distance, 2m horizon, Az: 34°, ATT, and FS. The background of the tablet shows a cityscape with a river and a bridge.

DJI IOSD SOLUTION

Install an iOSD MK II or iOSD mini to see real-time flight data.



UNBELIEVABLE INTELLIGENCE

Program your flight path from an iPad with the 16 waypoint Ground Station system, to shoot with more precision than ever.
(Requires DJI 2.4G Bluetooth(R) Datalink.)



Technology

ALL-IN-ONE NEW DESIGN



INTELLIGENT, LONG LASTING BATTERY

The high capacity, high performance 5200mAh Lithium Polymer battery offers up to 25 minutes of flight time. It provides battery capacity data, over charge/discharge protection, as well as maintenance reminders making the battery extremely safe and reliable.

25% – 50% – 75% – 100% Battery Capacity



FLIGHT TIME
25 Mins



GREATER CONTROL

The upgraded remote control comes with many new features. A gimbal control dial, trainer port, built-in rechargeable LiPo battery with a capacity of 2000mAh, battery level LED indicators and throttle locking feature that holds the throttle stick in place when descending are all included. The new remote control is compatible with the Phantom 2 Vision+ and Phantom 2.



Use DJI Lightbridge to control your aircraft or connect the remote control to your computer via the trainer port to run a simulation application and practice your flying skills.



IMPROVED POWER

New motors, propellers, and ESCs combine to give you greater thrust and control than ever before. You can load more equipment on your Phantom, and achieve up to 200g/arm of extra thrust when using a 3S LiPo battery with this completely new system.

NEW COMPASS

A new, anti-static compass has been developed, with a protective shell to help shield it in any flight conditions.





REPLACEMENT

Integrated battery compartment allows battery changes in a matter of seconds.

Functions



PRECISION FLIGHT AND STABLE HOVERING

An integrated GPS auto-pilot system that offers position holding, altitude lock and stable hovering allows you to focus attention to be focused on shooting.

Out of Range

Return to Home

AUTO RETURN-TO-HOME /ONE-KEY GO-HOME

If the Phantom 2 and its controller are disconnected during flight, the system's failsafe protection will activate, automatically telling and if the signal is good enough, the Phantom 2 to return home and land automatically.

You can also setup a One Key Go Home function to activate this feature manually.

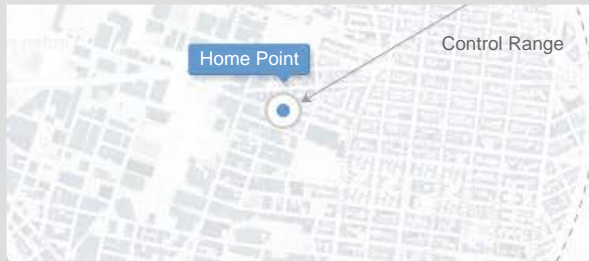

NO FLY ZONES FEATURE

In order to increase flight safety and prevent accidental flights in restricted areas, the new firmware for the Phantom 2 series includes a No Fly Zone feature.

These zones have been divided into two categories: A and B. For a full explanation of the difference between the categories and to view a complete list of places included, please [click here](#).



PHANTOM

Your Flying Camera

[learn more >](#)

COMPARE PHANTOMS



[Compare Now](#)

DJI OFFICIAL STORE



Buy from the DJI Official Store

[Buy Now](#)

DJI AUTHORIZED DEALERS



Buy from DJI authorized dealers

[Find a local dealer](#)

HELP AND SUPPORT



[Wiki](#)

[Downloads](#)

[Support](#)

[After-sales Service Policies](#)

PHANTOM 2

[Overview](#)
[Features](#)
[No Fly Zones](#)
[Specs](#)
[Videos](#)
[Downloads](#)
[Wiki](#)
[Dealers](#)
[Buy Now](#)

General Features

- Ready to Fly, Multifunctional Quad-rotor System
- Customized H3-2D and H3-3D Gimbal Support
- Precision Flight and Stable Hovering
- 25min Flight Time & Smart Battery
- Auto Return-to-Home & Landing
- Advanced Power Management
- Intelligent Orientation Control (IOC)
- Easy Battery Replacement
- Self-tightening Propeller
- Video Downlink Support
- CAN-Bus Expansion Module

Aircraft

Weight (Battery & Propellers Included)	1000g
Hover Accuracy (Ready To Fly)	Vertical: 0.8m; Horizontal: 2.5m
Max Yaw Angular Velocity	200°/s
Max Tilt Angle	35°
Max Ascent / Descent Speed	Ascent: 6m/s; Descent: 2m/s
Max Flight Speed	15m/s(Not Recommended)
Diagonal Length	350mm
Flight Time	25mins
Take-Off Weight	≤1300g

	Operating Temperature	-10°C ~ 50°C
	Supported Battery	DJI Smart Battery
DJI Smart Battery	Type	3S LiPo
	Capacity	5200mAh, 11.1V
	Charging Environment Range	0 to 40
	Discharging Environment Range	-20 to 50
2.4GHz Remote Control	Operating Frequency	2.4GHz ISM
	Communication Distance (Open Area)	1000m
	Receiver Sensitivity (1%PER)	-97dBm
	Working Current/Voltage	120 mA@3.7V
	Built-In LiPo Battery Working Current/Capacity	3.7V, 2000mAh

PHANTOM 2 VISION

[Overview](#)[Features](#)[No Fly Zones](#)[Specs](#)[Videos](#)[Downloads](#)[FAQ](#)[Wiki](#)[Dealers](#)[Buy Now](#)

PHANTOM 2 VISION

YOUR FLYING CAMERA



UNPRECEDENTED PHOTOGRAPHIC EXPERIENCE

Experience A New Level Of Photography

Real time live-view on your mobile device allows you take photos and videos from a completely new perspective.





SHARE YOUR PHOTOS & VIDEOS

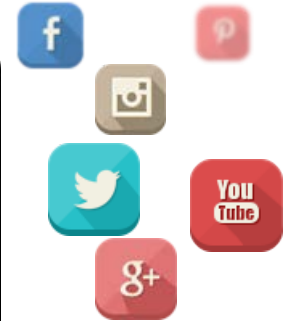

EXCEPTIONAL FLIGHT EXPERIENCE

- The first integrated mobile phone FPV (First Person View) system
- Wi-Fi wireless connection up to a distance of 300m
- Real-Time telemetry data and flight parameters

INTEGRATED HIGH END CAMERA



TAKE PHOTOS

14 Megapixel Still Image



RECORD VIDEO

1080/30p or 1080/60i



LIGHTWEIGHT EASY TO CARRY



WEIGHT

1160g



DIMENSIONS (CM)

29 x 29 x 18





FOV AND APERTURE

140 ° wide-angle f/2.8



FLIGHT TIME

25mins



GROUND STATION SUPPORT

Program a flight path using your smartphone with our 16 waypoint Ground Station system. Tilt the camera up and down, take photos and shoot video all while the Phantom 2 Vision+ flies autonomously.

[More Features](#) □



COMPARE PHANTOMS



[Compare Now](#) □

DJI OFFICIAL STORE



Buy from the DJI Official Store

[Buy Now](#) □

DJI AUTHORIZED DEALERS



Buy from DJI authorized dealers

[Find a local dealer](#) □

HELP AND SUPPORT



[Wiki](#) □

[Downloads](#) □

[Support](#) □

[After-sales Service Policies](#) □



PHANTOM 2 VISION

[Overview](#)[Features](#)[No Fly Zones](#)[Specs](#)[Videos](#)[Downloads](#)[FAQ](#)[Wiki](#)[Dealers](#)[Buy Now](#)

Body



Remote Control

click and drag



UNPRECEDENTED
PHOTOGRAPHIC EXPERIENCE



SHARE YOUR PHOTOS &

VIDEOS



EXCEPTIONAL FLIGHT
EXPERIENCE

UNPRECEDENTED PHOTOGRAPHIC EXPERIENCE





HIGH PERFORMANCE CAMERA

The Phantom 2 Vision carries an extremely high quality stills camera and a 4GB micro SD card. It shoots full HD video at 1080p 30/60i and takes 14 megapixel still photos.



CAMERA TILT CONTROL

During flight, the camera is stabilized on the tilt axis. Tilt control can be remotely controlled through the App making it simple and easy to use.





TAKE PHOTOS

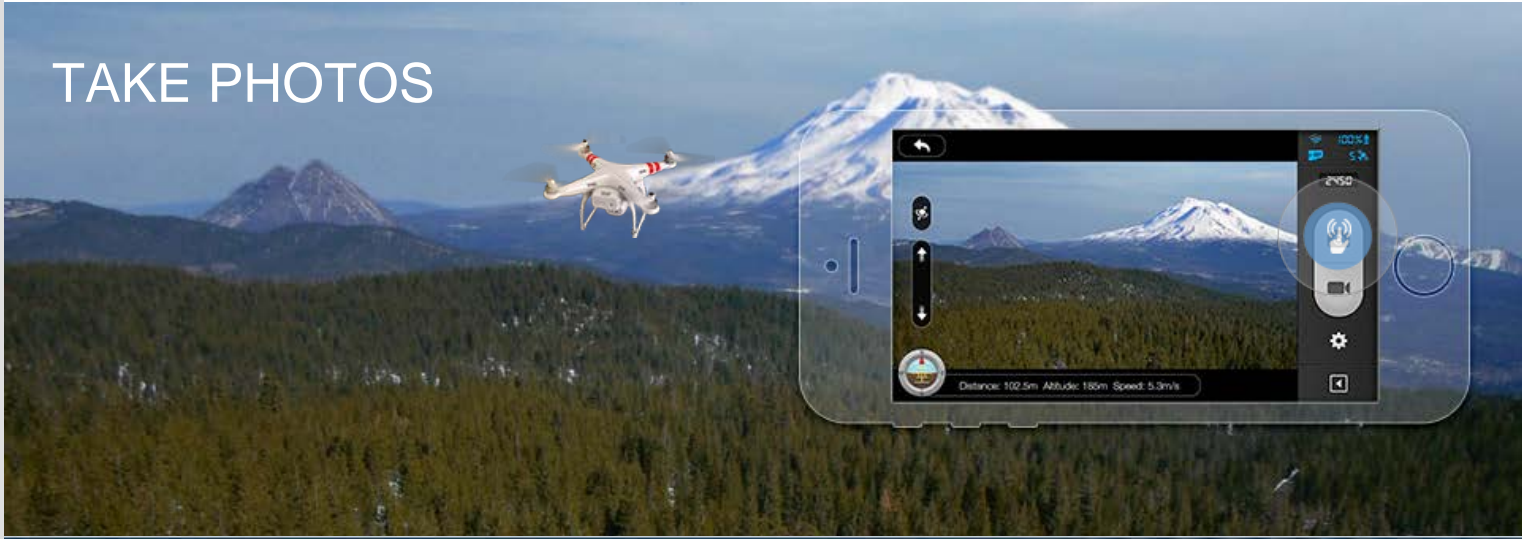

RECORD VIDEOS

REC



ADAPTERS SUPPORT VARIOUS 46MM LENS FILTERS

The innovative adapter supports a variety of 46MM lens filters, making your photo as colorful as you can imagine.

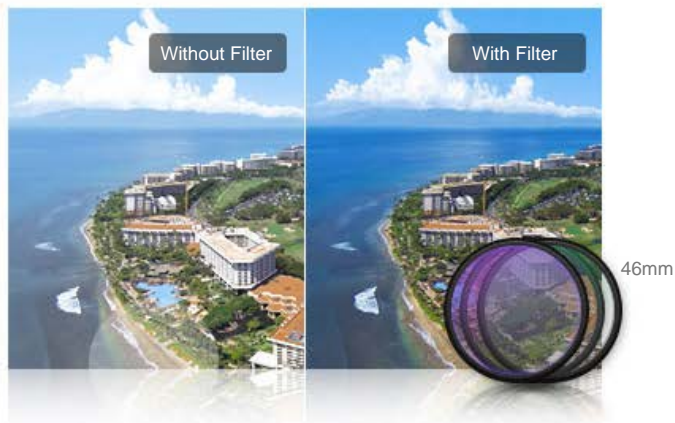

ADOBE LENS PROFILE SUPPORT

A lens profile released by Adobe for DJI Phantom 2 Vision's camera can be used to remove lens distortion

*Available as standard in the latest versions of Adobe Lightroom, Adobe Camera Raw for Photoshop and Adobe Premiere.

Before

After



SUPPORTS ADOBE DNG RAW

Photo in DNG RAW format captured by the Vision camera retains the original image information allowing for convenient post processing.



CAMERA PARAMETER SETTINGS



Camera settings including Picture Quality, ISO, Exposure Compensation, White Balance, and RAW or JPEG

capture can be adjusted through the Vision app.



WI-FI CONNECTION

Monitor real-time flight data along with live camera view up to a distance of 300m with a Wi-Fi wireless connection to your mobile device.

ALBUM SYNCHRONIZATION



Beam photos and videos from the Vision straight to your phone using Wi-Fi. No PC required.



SHARING

Share your timeless memories directly from the DJI Vision Mobile App.



EXCEPTIONAL FLIGHT EXPERIENCE



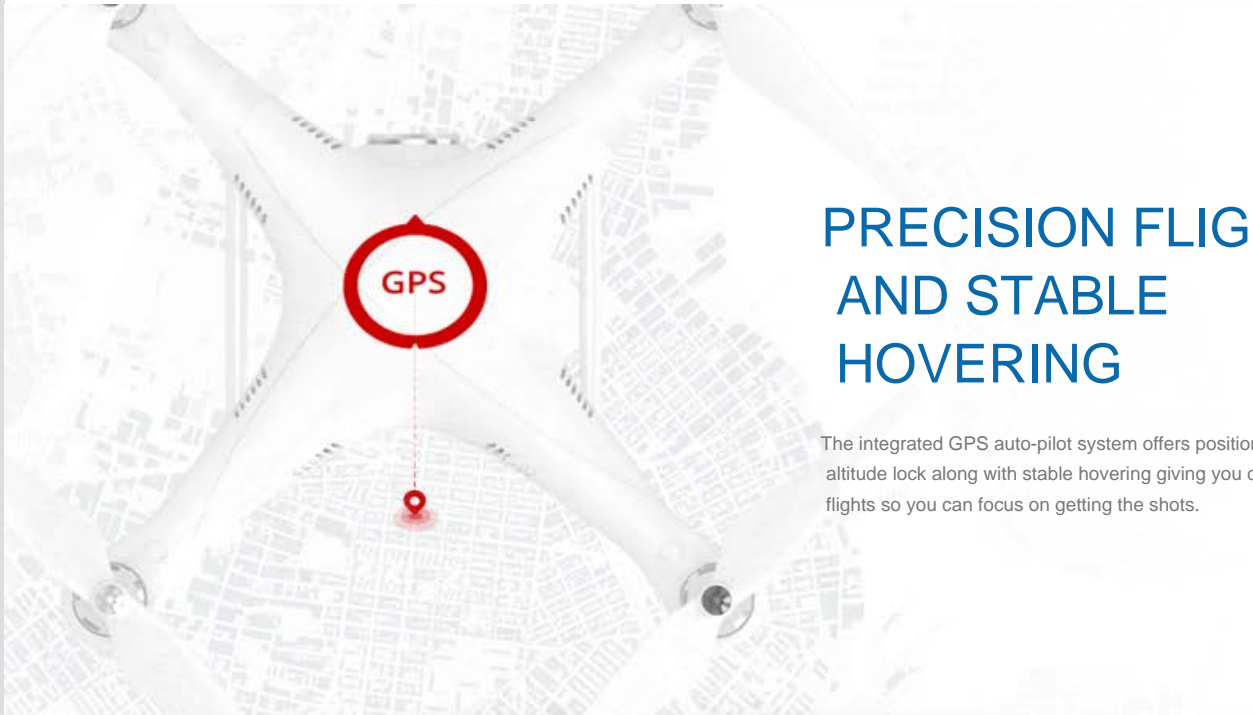

PRECISION FLIGHT AND STABLE HOVERING

The integrated GPS auto-pilot system offers position holding, provides altitude lock along with stable hovering giving you constant stable flights so you can focus on getting the shots.

NEW COMPASS

A new, anti-static compass has been developed, with a protective shell to help shield it in any flight conditions.



RADAR POSITIONING & RETURN HOME

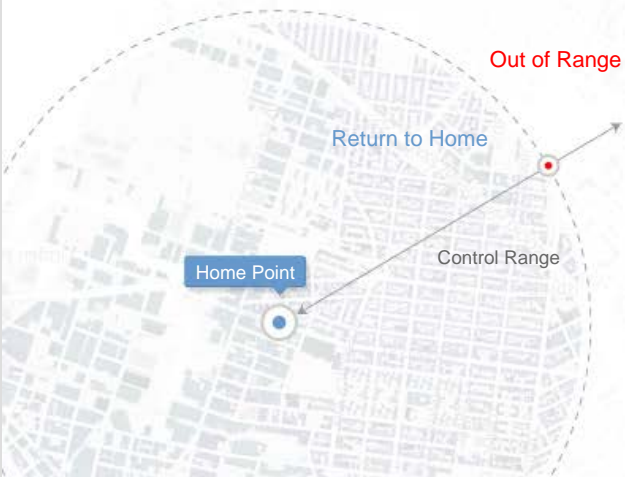

The flight radar can display the current position of the Phantom 2 Vision in relation to the pilot. Exceed the control range of the Remote Control and you'll trigger the 'Return-to-Home' feature which will automatically fly the Phantom 2 Vision back and safely land at its takeoff point.



ONSCREEN REAL-TIME FLIGHT PARAMETERS

Keep track of the current flight status with the onscreen display overlay.

Attitude & Direction
Height & Speed
Flight Distance

Wi-Fi Singal Strength
Battery Capacity
SD Card Status
GPS Satellites

Distance: 102.5m Altitude: 185m Speed: 5.3m/s

LONG FLIGHT TIME

The high capacity, high performance 5200mAh Lithium Polymer battery offers up to 25 minutes of flight time. It provides battery capacity data, over charge/discharge protection, as well as maintenance reminders making the battery extremely safe and reliable.

 FLIGHT TIME
25 Mins

25% – 50% – 75% – 100% Battery Capacity



EASY BATTERY REPLACEMENT

Integrated battery compartment allows battery changes in a matter of seconds.





SELF TIGHTENING PROPELLERS

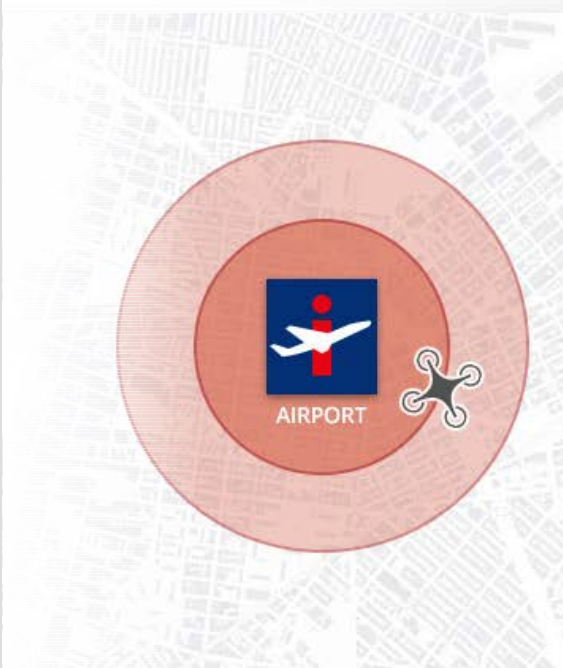

NO FLY ZONES FEATURE

In order to increase flight safety and prevent accidental flights in restricted areas, the new firmware for the Phantom 2 series includes a No Fly Zone feature.

These zones have been divided into two categories: A and B. For a full explanation of the difference between the categories and to view a complete list of places included, please [click here](#).



PHANTOM

Your Flying Camera

[learn more >](#)

COMPARE PHANTOMS



[Compare Now](#)

DJI OFFICIAL STORE



Buy from the DJI Official Store

[Buy Now](#)

DJI AUTHORIZED DEALERS



Buy from DJI authorized dealers

[Find a local dealer](#)

HELP AND SUPPORT



- [Wiki](#)
- [Downloads](#)
- [Support](#)
- [After-sales Service Policies](#)



PHANTOM 2 VISION

[Overview](#)
[Features](#)
[No Fly Zones](#)
[Specs](#)
[Videos](#)
[Downloads](#)
[FAQ](#)
[Wiki](#)
[Dealers](#)
[Buy Now](#)

General Features

- Lightweight, multi-functional integrated aircraft and camera
- Camera remote-control by DJI VISION APP
- Range Extender increases Wi-Fi distance to 300m
- Anti-vibration camera platform with single axis stabilisation
- Low-voltage protection
- Virtual Radar aircraft locator on mobile device
- Range of camera tilt options
- Multiple, continuous and timed capture options
- HD Video Recording (1080/p30 or 1080/60i)
- RAW and JPEG picture formats

Aircraft

Battery	5200mAh LiPo
Weight (Battery & Propellers Included)	1160g
Hover Accuracy (Ready To Fly)	Vertical: 0.8m; Horizontal: 2.5m
Max Yaw Angular Velocity	200°/s
Max Tilt Angle	35°
Max Ascent / Descent Speed	Ascent: 6m/s; Descent: 2m/s
Max Flight Speed	15m/s (Not Recommended)
Diagonal Length	350mm
Tilting Range Of Gimbal	0°-60°

Transmitter	Operating Frequency	5.728GHz 5.8GHz
	Communication Distance (Open Area)	CE: 300m; FCC: 500m
	Receiver Sensitivity (1%PER)	-93dBm
	Transmitter Power	CE: 25mw; FCC: 125mw
	Working Voltage	80 mA@6V
	Battery	4 AA Batteries
Camera	Resolution	14 Megapixels
	FOV	120°/ 110°/ 85°
	Sensor Size	1/2.3"
	Functionality	<ul style="list-style-type: none"> • Support of multi-capture, continuous capture and timed capture • Support of HD Recording (1080/p30 or 1080/60i) • Supports of both RAW and JPEG picture format
Range Extender	Operating Frequency	2412-2462MHz
	Communication Distance (Open Area)	300m
	Transmitter Power	<=17dBm
	Power Consumption	1.5W
DJI VISION App	System Requirement Of Mobile Device	iOS version 6.1 or above/ Android system version 4.0 or above
	Mobile Device Support	<ul style="list-style-type: none"> • iOS recommended: iPhone 4s, iPhone 5, iPhone 5s, iPhone 6, iPhone 6 Plus, iPod touch 5 (available but not recommended: iPad 3, iPad 4, iPad mini)

- Android recommended: Samsung Galaxy S3, S4, Note 2, Note 3 or phones of similar configuration



COMPARE PHANTOMS



[Compare Now](#) □

DJI OFFICIAL STORE



Buy from the DJI Official Store

[Buy Now](#) □

DJI AUTHORIZED DEALERS



Buy from DJI authorized dealers

[Find a local dealer](#) □

HELP AND SUPPORT



[Wiki](#) □

[Downloads](#) □

[Support](#) □

[After-sales Service Policies](#) □

PHANTOM 2 VISION

[Overview](#)[Features](#)[No Fly Zones](#)[Specs](#)[Videos](#)[Downloads](#)[FAQ](#)[Wiki](#)[Dealers](#)[Buy Now](#)

PHANTOM 2 VISION

YOUR FLYING CAMERA



UNPRECEDENTED PHOTOGRAPHIC EXPERIENCE

Experience A New Level Of Photography

Real time live-view on your mobile device allows you take photos and videos from a completely new perspective.





SHARE YOUR PHOTOS & VIDEOS

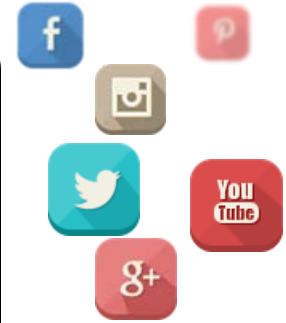

EXCEPTIONAL FLIGHT EXPERIENCE

- The first integrated mobile phone FPV (First Person View) system
- Wi-Fi wireless connection up to a distance of 300m
- Real-Time telemetry data and flight parameters

INTEGRATED HIGH END CAMERA



TAKE PHOTOS

14 Megapixel Still Image



RECORD VIDEO

1080/30p or 1080/60i



LIGHTWEIGHT EASY TO CARRY



WEIGHT

1160g



DIMENSIONS (CM)

29 x 29 x 18





FOV AND APERTURE

140 ° wide-angle f/2.8



FLIGHT TIME

25mins



GROUND STATION SUPPORT

Program a flight path using your smartphone with our 16 waypoint Ground Station system. Tilt the camera up and down, take photos and shoot video all while the Phantom 2 Vision+ flies autonomously.

[More Features](#) □



COMPARE PHANTOMS



[Compare Now](#) □

DJI OFFICIAL STORE



Buy from the DJI Official Store

[Buy Now](#) □

DJI AUTHORIZED DEALERS



Buy from DJI authorized dealers

[Find a local dealer](#) □

HELP AND SUPPORT



[Wiki](#) □

[Downloads](#) □

[Support](#) □

[After-sales Service Policies](#) □

PHANTOM 2 VISION+

[Overview](#)
[Features](#)
[No Fly Zones](#)
[Specs](#)
[Videos](#)
[Downloads](#)
[FAQ](#)
[Wiki](#)
[Dealers](#)
[Buy Now](#)

Body



Remote Control

click and drag

RADAR POSITIONING & RETURN HOME

- The flight radar displays the current position of the Phantom 2 Vision+ in relation to the pilot.
- Exceeding the control range of the remote control will trigger 'Return-to-Home', meaning the Phantom 2 Vision+ will automatically fly back to its takeoff point and land safely.

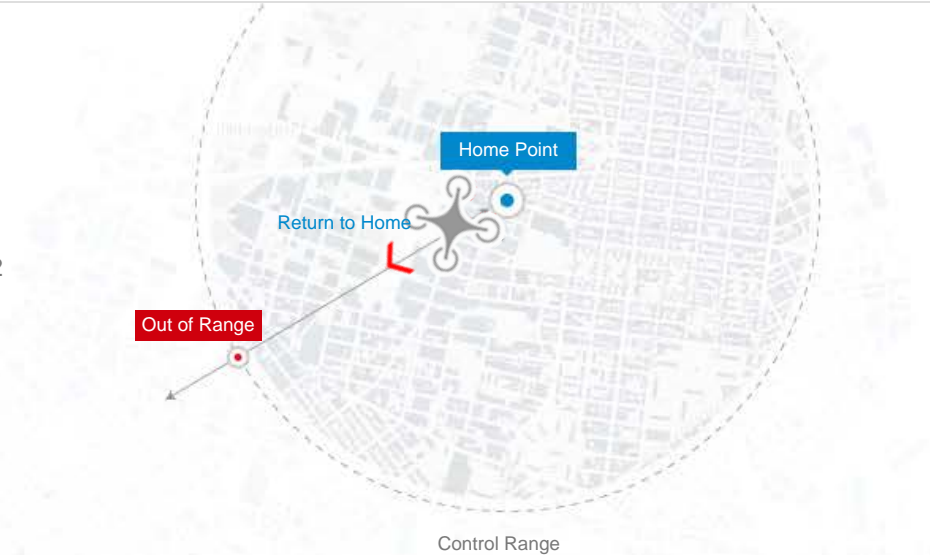

Max flight time



ONSCREEN REAL-TIME FLIGHT PARAMETERS

Keep track of current flight telemetry and see what your Phantom sees on your mobile device.

[Radar positioning](#)

[Flight parameters](#)

[Return home](#)



HIGH PERFORMANCE CAMERA

The Phantom 2 Vision+ carries an extremely high quality camera and a removable 4GB micro SD card. It shoots full HD video at 1080p/30fps and 720p/60fps, giving you crystal clear video and the option for slow motion shots. Photos are shot at 14 megapixels.

[View actual photos taken with the Phantom 2 Vision+ □](#)

CAMERA TILT CONTROL

Tilt the camera as you fly, creating unique angles and amazing shots.



GREATER CONTROL

The upgraded remote control comes with many new features. A gimbal control dial, trainer port, built-in rechargeable LiPo battery with a capacity of 2000mAh, battery level LED indicators and throttle locking feature that holds the throttle stick in place when descending are all included. The new remote control is compatible with the

Gimbal Control



Phantom 2 Vision+ and Phantom 2.



Use DJI Lightbridge to control your aircraft or connect the remote control to your computer via the trainer port to run a simulation application and practice your flying skills.



IMPROVED POWER

New motors, propellers, and ESCs combine to give you greater thrust and control than ever before. You can load more equipment on your Phantom, and achieve up to 200g/arm of extra thrust when using a 3S LiPo battery with this completely new system.

NEW COMPASS

A new, anti-static compass has been developed, with a protective shell to help shield it in any flight conditions.



READY TO FLY

Point the camera straight down for a totally unique view of your world.

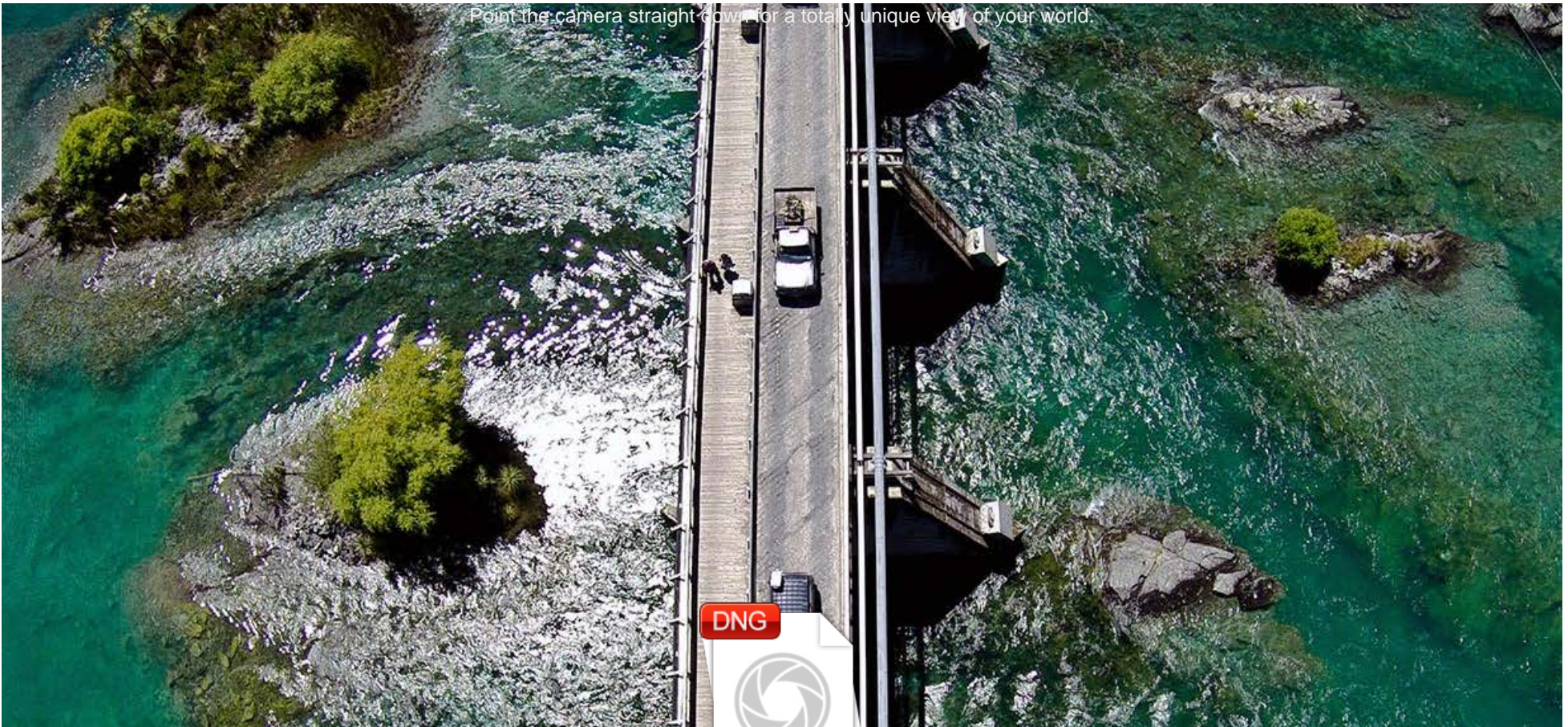

SUPPORTS ADOBE DNG RAW

DNG RAW photo capture means all original image information is retained for powerful post processing.



ADOBE LENS PROFILE SUPPORT

An Adobe lens profile for barrel distortion removal is available for the DJI Phantom 2 Vision+ camera.

* Available as standard in the latest versions of Adobe Lightroom, Adobe Camera Raw for Photoshop and Adobe Premiere.



Before



After

CAMERA PARAMETER SETTINGS



Camera settings including Picture Quality, ISO, Exposure Compensation, White Balance, and capture Format can be adjusted through the VISION app.



SYNCHRONIZATION

Beam photos and videos from the Vision+ straight to your phone using Wi-Fi. No computer required.

Up to 700m
Wi-Fi connection



NO FLY ZONES FEATURE

In order to increase flight safety and prevent accidental flights in restricted areas, the new firmware for the Phantom 2 series includes a No Fly Zone feature.

These zones have been divided into two categories: A and B. For a full explanation of the difference between the categories and to view a complete list of places included, please [click here](#).



PHANTOM

Your Flying Camera

[learn more >](#)

COMPARE PHANTOMS



[Compare Now](#)

DJI OFFICIAL STORE



Buy from the DJI Official Store

[Buy Now](#)

DJI AUTHORIZED DEALERS



Buy from DJI authorized dealers

[Find a local dealer](#)

HELP AND SUPPORT



- [Wiki](#)
- [Downloads](#)
- [Support](#)
- [After-sales Service Policies](#)



[STORE](#)[PRODUCTS](#)[SUPPORT](#)[COMMUNITY](#)[DEVELOPER](#)[Worldwide \(English\)](#)

PHANTOM 2 VISION+

[Overview](#)[Features](#)[No Fly Zones](#)[Specs](#)[Videos](#)[Downloads](#)[FAQ](#)[Wiki](#)[Dealers](#)[Buy Now](#)

Aircraft	Supported Battery	DJI 5200mAh LiPo Battery
	Weight (Battery & Propellers Included)	1242g
	Hover Accuracy (Ready To Fly)	Vertical: 0.8m; Horizontal: 2.5m
	Max Yaw Angular Velocity	200°/s
	Max Tilttable Angle	35°
	Max Ascent / Descent Speed	Ascent: 6m/s; Descent: 2m/s
	Max Flight Speed	15m/s (Not Recommended)
	Diagonal Motor-Motor Distance	350mm
Gimbal	Working Current	Static : 750mA; Dynamic : 900mA
	Control Accuracy	±0.03°
	Controllable Range	Pitch : -90° 0°
	Maximum Angular Speed	Pitch : 90°/s
Camera	Operating Environment Temperature	0 -40
	Sensor Size	120 1/2.3"

	Effective Pixels	14 Megapixels
	Resolution	4384×3288
	HD Recording	1080p30 & 720p
	Recording FOV	110° / 85°
Remote Control	Operating Frequency	5.728 GHz 5.85 GHz
	Communication Distance (Open Area)	CE Compliance: 400m; FCC Compliance: 800m
	Receiver Sensitivity (1%PER)	-93dBm
	Transmitter Power	CE Compliance: 25mW; FCC Compliance: 100mW
	Working Voltage	120 mA@3.7V
	Built-In LiPo Battery Working Current/Capacity	3.7V, 2000mAh
	Range Extender	Operating Frequency
Communication Distance (Open Area)		500-700m
Transmitter Power		20dBm
Power Consumption		2W
DJI VISION App	System Requirement Of Mobile Device	iOS version 6.1 or above/ Android system version 4.0 or above
	Mobile Device Support	<ul style="list-style-type: none"> • iOS recommended: iPhone 4s, iPhone 5, iPhone 5s, iPhone 6, iPhone 6 Plus, iPod touch 5 (available but not recommended: iPad 3, iPad 4, iPad mini) • Android recommended: Samsung Galaxy S3, S4, Note 2, Note 3 or phones of similar configuration



COMPARE PHANTOMS



[Compare Now](#) □

DJI OFFICIAL STORE



Buy from the DJI Official Store

[Buy Now](#) □

DJI AUTHORIZED DEALERS



Buy from DJI authorized dealers

[Find a local dealer](#) □

HELP AND SUPPORT



- [Wiki](#) □
- [Downloads](#) □
- [Support](#) □
- [After-sales Service Policies](#) □





STORE

PRODUCTS

SUPPORT

COMMUNITY

DEVELOPER

Worldwide (English)

PHANTOM 2 VISION+

[Overview](#)

[Features](#)

[No Fly Zones](#)

[Specs](#)

[Videos](#)

[Downloads](#)

[FAQ](#)

[Wiki](#)

[Dealers](#)

[Buy Now](#)

PHANTOM 2 VISION+

YOUR FLYING CAMERA

[New Pilot Experience 2015](#)



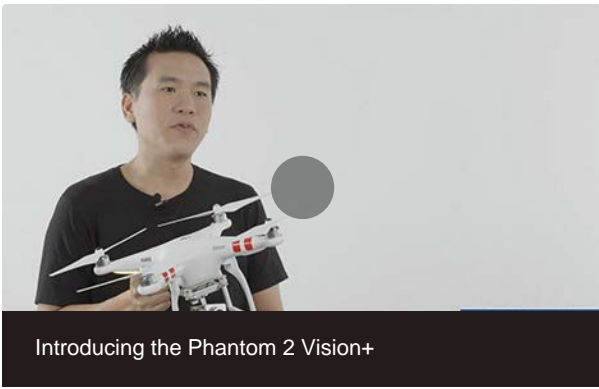

[More Features](#)



[COMPARE PHANTOMS](#)

[DJI OFFICIAL STORE](#)

[DJI AUTHORIZED DEALERS](#)

[HELP AND SUPPORT](#)





[Compare Now](#) □

[Buy from the DJI Official Store](#)

[Buy Now](#) □

[Buy from DJI authorized dealers](#)

[Find a local dealer](#) □

[Wiki](#) □

[Downloads](#) □

[Support](#) □

[After-sales Service Policies](#) □

[About DJI](#) | [Contact DJI](#) | [News](#) | [Media Coverage](#) | [Showcase](#) | [Careers](#) | [DJI Wiki](#) | [After-sales Service Policies](#) | [Website Feedback](#) | [DJI Developer](#)

 **THE FUTURE OF POSSIBLE** Copyright © 2015 DJI All Rights Reserved. [Privacy Policy](#) [Terms of Use](#)

