



U.S. Department
of Transportation
**Federal Aviation
Administration**

800 Independence Ave., S.W.
Washington, D.C. 20591

July 31, 2015

Exemption No. 12266
Regulatory Docket No. FAA-2015-2116

Mr. Ryan Koverman
President
Windy City Drones, LLC
450 Village Creek Drive
Lake in the Hills, IL 60156

Dear Mr. Koverman:

This letter is to inform you that we have granted your request for exemption. It transmits our decision, explains its basis, and gives you the conditions and limitations of the exemption, including the date it ends.

By letter dated May 28, 2015, you petitioned the Federal Aviation Administration (FAA) on behalf of Windy City Drones, LLC (hereinafter petitioner or operator) for an exemption. The petitioner requested to operate an unmanned aircraft system (UAS) to conduct aerial photography, tower inspection, real estate marketing, surveying, agricultural mapping, and other flight operations.

See Appendix A for the petition submitted to the FAA describing the proposed operations and the regulations that the petitioner seeks an exemption.

The FAA has determined that good cause exists for not publishing a summary of the petition in the Federal Register because the requested exemption would not set a precedent, and any delay in acting on this petition would be detrimental to the petitioner.

Airworthiness Certification

The UAS proposed by the petitioner is a DJI Phantom 3 Professional.

The petitioner requested relief from 14 CFR part 21, *Certification procedures for products and parts, Subpart H—Airworthiness Certificates*. In accordance with the statutory criteria provided in Section 333 of Public Law 112–95 in reference to 49 U.S.C. § 44704, and in consideration of the size, weight, speed, and limited operating area associated with the aircraft and its operation, the Secretary of Transportation has determined that this aircraft meets the conditions of Section 333. Therefore, the FAA finds that the requested relief from 14 CFR part 21, *Certification procedures for products and parts, Subpart H—Airworthiness Certificates*, and any associated noise certification and testing requirements of part 36, is not necessary.

The Basis for Our Decision

You have requested to use a UAS for aerial data collection¹. The FAA has issued grants of exemption in circumstances similar in all material respects to those presented in your petition. In Grants of Exemption Nos. 11062 to Astraeus Aerial (*see* Docket No. FAA–2014–0352), 11109 to Clayco, Inc. (*see* Docket No. FAA–2014–0507), 11112 to VDOS Global, LLC (*see* Docket No. FAA–2014–0382), and 11213 to Aeryon Labs, Inc. (*see* Docket No. FAA–2014–0642), the FAA found that the enhanced safety achieved using an unmanned aircraft (UA) with the specifications described by the petitioner and carrying no passengers or crew, rather than a manned aircraft of significantly greater proportions, carrying crew in addition to flammable fuel, gives the FAA good cause to find that the UAS operation enabled by this exemption is in the public interest.

Having reviewed your reasons for requesting an exemption, I find that—

- They are similar in all material respects to relief previously requested in Grant of Exemption Nos. 11062, 11109, 11112, and 11213;
- The reasons stated by the FAA for granting Exemption Nos. 11062, 11109, 11112, and 11213 also apply to the situation you present; and
- A grant of exemption is in the public interest.

Our Decision

In consideration of the foregoing, I find that a grant of exemption is in the public interest. Therefore, pursuant to the authority contained in 49 U.S.C. 106(f), 40113, and 44701, delegated to me by the Administrator, Windy City Drones, LLC is granted an exemption from 14 CFR §§ 61.23(a) and (c), 61.101(e)(4) and (5), 61.113(a), 61.315(a), 91.7(a), 91.119(c), 91.121, 91.151(a)(1), 91.405(a), 91.407(a)(1), 91.409(a)(1) and (2), and 91.417(a) and (b), to

¹ Aerial data collection includes any remote sensing and measuring by an instrument(s) aboard the UA. Examples include imagery (photography, video, infrared, etc.), electronic measurement (precision surveying, RF analysis, etc.), chemical measurement (particulate measurement, etc.), or any other gathering of data by instruments aboard the UA.

the extent necessary to allow the petitioner to operate a UAS to perform aerial data collection. This exemption is subject to the conditions and limitations listed below.

Conditions and Limitations

In this grant of exemption, Windy City Drones, LLC is hereafter referred to as the operator.

Failure to comply with any of the conditions and limitations of this grant of exemption will be grounds for the immediate suspension or rescission of this exemption.

1. Operations authorized by this grant of exemption are limited to the DJI Phantom 3 Professional when weighing less than 55 pounds including payload. Proposed operations of any other aircraft will require a new petition or a petition to amend this exemption.
2. Operations for the purpose of closed-set motion picture and television filming are not permitted.
3. The UA may not be operated at a speed exceeding 87 knots (100 miles per hour). The exemption holder may use either groundspeed or calibrated airspeed to determine compliance with the 87 knot speed restriction. In no case will the UA be operated at airspeeds greater than the maximum UA operating airspeed recommended by the aircraft manufacturer.
4. The UA must be operated at an altitude of no more than 400 feet above ground level (AGL). Altitude must be reported in feet AGL.
5. The UA must be operated within visual line of sight (VLOS) of the PIC at all times. This requires the PIC to be able to use human vision unaided by any device other than corrective lenses, as specified on the PIC's FAA-issued airman medical certificate or U.S. driver's license.
6. All operations must utilize a visual observer (VO). The UA must be operated within the visual line of sight (VLOS) of the PIC and VO at all times. The VO may be used to satisfy the VLOS requirement as long as the PIC always maintains VLOS capability. The VO and PIC must be able to communicate verbally at all times; electronic messaging or texting is not permitted during flight operations. The PIC must be designated before the flight and cannot transfer his or her designation for the duration of the flight. The PIC must ensure that the VO can perform the duties required of the VO.
7. This exemption and all documents needed to operate the UAS and conduct its operations in accordance with the conditions and limitations stated in this grant of exemption, are hereinafter referred to as the operating documents. The operating

documents must be accessible during UAS operations and made available to the Administrator upon request. If a discrepancy exists between the conditions and limitations in this exemption and the procedures outlined in the operating documents, the conditions and limitations herein take precedence and must be followed.

Otherwise, the operator must follow the procedures as outlined in its operating documents. The operator may update or revise its operating documents. It is the operator's responsibility to track such revisions and present updated and revised documents to the Administrator or any law enforcement official upon request. The operator must also present updated and revised documents if it petitions for extension or amendment to this grant of exemption. If the operator determines that any update or revision would affect the basis upon which the FAA granted this exemption, then the operator must petition for an amendment to its grant of exemption. The FAA's UAS Integration Office (AFS-80) may be contacted if questions arise regarding updates or revisions to the operating documents.

8. Any UAS that has undergone maintenance or alterations that affect the UAS operation or flight characteristics, e.g., replacement of a flight critical component, must undergo a functional test flight prior to conducting further operations under this exemption. Functional test flights may only be conducted by a PIC with a VO and must remain at least 500 feet from other people. The functional test flight must be conducted in such a manner so as to not pose an undue hazard to persons and property.
9. The operator is responsible for maintaining and inspecting the UAS to ensure that it is in a condition for safe operation.
10. Prior to each flight, the PIC must conduct a pre-flight inspection and determine the UAS is in a condition for safe flight. The pre-flight inspection must account for all potential discrepancies, e.g., inoperable components, items, or equipment. If the inspection reveals a condition that affects the safe operation of the UAS, the aircraft is prohibited from operating until the necessary maintenance has been performed and the UAS is found to be in a condition for safe flight.
11. The operator must follow the UAS manufacturer's maintenance, overhaul, replacement, inspection, and life limit requirements for the aircraft and aircraft components.
12. Each UAS operated under this exemption must comply with all manufacturer safety bulletins.
13. Under this grant of exemption, a PIC must hold either an airline transport, commercial, private, recreational, or sport pilot certificate. The PIC must also hold a current FAA airman medical certificate or a valid U.S. driver's license issued by a state, the District of Columbia, Puerto Rico, a territory, a possession, or the Federal

government. The PIC must also meet the flight review requirements specified in 14 CFR § 61.56 in an aircraft in which the PIC is rated on his or her pilot certificate.

14. The operator may not permit any PIC to operate unless the PIC demonstrates the ability to safely operate the UAS in a manner consistent with how the UAS will be operated under this exemption, including evasive and emergency maneuvers and maintaining appropriate distances from persons, vessels, vehicles and structures. PIC qualification flight hours and currency must be logged in a manner consistent with 14 CFR § 61.51(b). Flights for the purposes of training the operator's PICs and VOs (training, proficiency, and experience-building) and determining the PIC's ability to safely operate the UAS in a manner consistent with how the UAS will be operated under this exemption are permitted under the terms of this exemption. However, training operations may only be conducted during dedicated training sessions. During training, proficiency, and experience-building flights, all persons not essential for flight operations are considered nonparticipants, and the PIC must operate the UA with appropriate distance from nonparticipants in accordance with 14 CFR § 91.119.
15. UAS operations may not be conducted during night, as defined in 14 CFR § 1.1. All operations must be conducted under visual meteorological conditions (VMC). Flights under special visual flight rules (SVFR) are not authorized.
16. The UA may not operate within 5 nautical miles of an airport reference point (ARP) as denoted in the current FAA Airport/Facility Directory (AFD) or for airports not denoted with an ARP, the center of the airport symbol as denoted on the current FAA-published aeronautical chart, unless a letter of agreement with that airport's management is obtained or otherwise permitted by a COA issued to the exemption holder. The letter of agreement with the airport management must be made available to the Administrator or any law enforcement official upon request.
17. The UA may not be operated less than 500 feet below or less than 2,000 feet horizontally from a cloud or when visibility is less than 3 statute miles from the PIC.
18. If the UAS loses communications or loses its GPS signal, the UA must return to a pre-determined location within the private or controlled-access property.
19. The PIC must abort the flight in the event of unpredicted obstacles or emergencies.
20. The PIC is prohibited from beginning a flight unless (considering wind and forecast weather conditions) there is enough available power for the UA to conduct the intended operation and to operate after that for at least five minutes or with the reserve power recommended by the manufacturer if greater.
21. Air Traffic Organization (ATO) Certificate of Waiver or Authorization (COA). All operations shall be conducted in accordance with an ATO-issued COA. The

exemption holder may apply for a new or amended COA if it intends to conduct operations that cannot be conducted under the terms of the attached COA.

22. All aircraft operated in accordance with this exemption must be identified by serial number, registered in accordance with 14 CFR part 47, and have identification (N-Number) markings in accordance with 14 CFR part 45, Subpart C. Markings must be as large as practicable.
23. Documents used by the operator to ensure the safe operation and flight of the UAS and any documents required under 14 CFR §§ 91.9 and 91.203 must be available to the PIC at the Ground Control Station of the UAS any time the aircraft is operating. These documents must be made available to the Administrator or any law enforcement official upon request.
24. The UA must remain clear and give way to all manned aviation operations and activities at all times.
25. The UAS may not be operated by the PIC from any moving device or vehicle.
26. All Flight operations must be conducted at least 500 feet from all nonparticipating persons, vessels, vehicles, and structures unless:
 - a. Barriers or structures are present that sufficiently protect nonparticipating persons from the UA and/or debris in the event of an accident. The operator must ensure that nonparticipating persons remain under such protection. If a situation arises where nonparticipating persons leave such protection and are within 500 feet of the UA, flight operations must cease immediately in a manner ensuring the safety of nonparticipating persons; and
 - b. The owner/controller of any vessels, vehicles or structures has granted permission for operating closer to those objects and the PIC has made a safety assessment of the risk of operating closer to those objects and determined that it does not present an undue hazard.

The PIC, VO, operator trainees or essential persons are not considered nonparticipating persons under this exemption.

27. All operations shall be conducted over private or controlled-access property with permission from the property owner/controller or authorized representative. Permission from property owner/controller or authorized representative will be obtained for each flight to be conducted.
28. Any incident, accident, or flight operation that transgresses the lateral or vertical boundaries of the operational area as defined by the applicable COA must be reported to the FAA's UAS Integration Office (AFS-80) within 24 hours. Accidents must be

reported to the National Transportation Safety Board (NTSB) per instructions contained on the NTSB Web site: www.nts.gov.

If this exemption permits operations for the purpose of closed-set motion picture and television filming and production, the following additional conditions and limitations apply.

29. The operator must have a motion picture and television operations manual (MPTOM) as documented in this grant of exemption.
30. At least 3 days before aerial filming, the operator of the UAS affected by this exemption must submit a written Plan of Activities to the local Flight Standards District Office (FSDO) with jurisdiction over the area of proposed filming. The 3-day notification may be waived with the concurrence of the FSDO. The plan of activities must include at least the following:
 - a. Dates and times for all flights;
 - b. Name and phone number of the operator for the UAS aerial filming conducted under this grant of exemption;
 - c. Name and phone number of the person responsible for the on-scene operation of the UAS;
 - d. Make, model, and serial or N-Number of UAS to be used;
 - e. Name and certificate number of UAS PICs involved in the aerial filming;
 - f. A statement that the operator has obtained permission from property owners and/or local officials to conduct the filming production event; the list of those who gave permission must be made available to the inspector upon request;
 - g. Signature of exemption holder or representative; and
 - h. A description of the flight activity, including maps or diagrams of any area, city, town, county, and/or state over which filming will be conducted and the altitudes essential to accomplish the operation.
31. Flight operations may be conducted closer than 500 feet from participating persons consenting to be involved and necessary for the filming production, as specified in the exemption holder's MPTOM.

Unless otherwise specified in this grant of exemption, the UAS, the UAS PIC, and the UAS operations must comply with all applicable parts of 14 CFR including, but not limited to, parts 45, 47, 61, and 91.

This exemption terminates on August 31, 2017, unless sooner superseded or rescinded.

Sincerely,

/s/

John S. Duncan
Director, Flight Standards Service

Enclosures

May 28th, 2015

Ryan Koverman
Windy City Drones
450 Village Creek Dr.
Lake in the Hills, IL 60156

DEPARTMENT OF
TRANSPORTATION
FAA
705 201-4 A II: 52

U.S. Department of Transportation
Docket Operations
West Building Ground Floor
Room W12-140
1200 New Jersey Avenue, SE.,
Washington, DC 20590-0001

RE: Exemption Request Section 333 of the FAA Reform Act of 2012 and Part 11 of the Federal Aviation Regulations

Dear Sir or Madam;

In accordance with the Public Guidance for Petitions for Exemption filed under Section 333, Windy City Drones, LLC requests exemption from the Federal Aviation Regulations to allow for commercial UAS operations of a DJI Phantom 3 Professional, for the purpose of aerial photography, tower inspection, real estate marketing, surveying, agricultural mapping and other flight operations that could be performed safely and more cost effectively than a traditional manned aircraft.

Applicant:
Windy City Drones
Ryan Koverman (President)
450 Village Creek Dr.
Lake in the Hills, IL 60156

(630) 246-7443

Attachments:

1. DJI Phantom 3 Professional User Manual
2. DJI Phantom 3 Professional Quick Start Guide
3. DJI Phantom 3 Professional Release Notes
4. DJI Phantom 3 Safety Guidelines Disclaimer
5. DJI Phantom Pilot Training Guide
6. Intelligent Flight Battery Safety Guidelines

Regulations from which the exemption is requested:

- 14 CFR 21, Subpart H
- 14 CFR 45.23 (b)
- 14 CFR 61.113 (a) & (b) & 14 CFR 61.133 (a)
- 14 CFR 91.7 (a)
- 14 CFR 91.9 (b)(2)
- 14 CFR 91.103 (b)(2)
- 14 CFR 91.109

14 CFR 91.119 (c)
14 CFR 91.121
14 CFR 91.151 (a)
14 CFR 91.203 (a) & (b)
14 CFR 91.405 (a)
14 CFR 91.407 (a)(1)
14 CFR 91.409 (a)(1) & (a)(2)
14 CFR 91.417 (a) & (b)

14 CFR 21, Subpart H – In consideration of the size, weight, speed, and limited operating area associated with this UAS and its operation, Windy City Drones requests relief from 14 CFR part 21, Subpart H, and any associated noise certification and testing requirements of part 36. The UAS will carry neither pilot, passenger, explosive materials or flammable liquids.

14 CFR 45.23 (b) - Even though the UAS will have no airworthiness certificate, an exemption may be needed as the UAS will have no entrance to the cabin, cockpit or pilot station on which the word “Experimental” can be placed. Given the size of the UAS, two-inch lettering will be impossible. The word “Experimental” will be placed on the fuselage in compliance with §45.29 (f). The equivalent level of safety will be provided by having the UAS marked on its fuselage as required by §45.29 (f) where the pilot, observer and others working with the UAS will see the identification of the UAS as “Experimental.”

14 CFR 61.113 (a) & (b) & 14 CFR 61.133 (a) – Since the UAS will not carry a pilot or passengers Windy City Drones requests a relief from these regulations. Any pilot in command or (PIC) operating the UAS will hold a Sport Pilot (or greater) certificate. A visual observer or (VO) will be utilized and required to communicate verbally at all times. The UAS will be limited to operations within visual distance of both the PIC and VO. All UAS operations will take place in a controlled area. The risks associated with the use of a UAS are far less than similar commercial aircraft operations.

14 CFR 91.7 (a) – Since the UAS will not carry a pilot or passengers there will be no airworthiness certificate issued for the aircraft, should this exemption be granted, no FAA regulatory standard exists for determining airworthiness. Given the size of the aircraft, maintenance, and use of safety checklist prior to each flight, an equivalent level of safety will be provided. All flights will be in accordance with the safety and maintenance recommendations found in the DJI Phantom attachments.

14 CFR 91.9 (b)(2) – Given the size and configuration, the UAS has no ability to carry a flight manual on the aircraft. There is no room, capacity, or pilot on board to adequately carry a flight manual. An equivalent level of safety will be maintained by keeping the flight manual at the ground station where the UAS pilot will have immediate access to it.

14 CFR 91.103 (b)(2) – As no FAA approved flight manuals will be provided for the aircraft an exemption is needed. Alternate procedures including but not limited to reviewing weather conditions, checking flight battery requirements, checking takeoff and landing distances along with those found in the attached “DJI Pilot Training” will be implemented. These actions will provide an equivalent or higher level of safety.

14 CFR 91.109 – UAS and remotely piloted aircraft do not have fully functional dual controls. Flight control is achieved through the use of a control box that communicates with the aircraft via radio communications. An equivalent level of safety will be achieved using the real time ground station data

and given the UAS will carry neither a pilot or passengers.

14 CFR 91.119 (c) – The UAS will never be operated at an altitude higher than 400 feet AGL. The UAS will operate in safe areas away from public and traffic and only with permission of the property and structure owners. The UAS will also be restricted by the flight controller to a maximum vertical height of 400 feet AGL, and 1500 feet horizontal. Given the size, weight, maneuverability and speed of the UAS, an equivalent or higher level of safety will be achieved.

14 CFR 91.121 – As the UAS may not have a barometric altimeter, but instead a GPS barometric sensor for altitude information an exemption may be required. An equivalent level of safety will be achieved using a ground station which links to a telemetry data link. This will provide the pilot with live flight data monitoring, confirming the altitude of the launch site shown on the GPS altitude indicator prior to flight.

14 CFR 91.151 (a) – The UAS has a limited range and will be limited to operations in a controlled environment. The battery power the UAS provides approximately 23 minutes of flight time. The UAS is unable to meet the 30 minute reserve requirement and therefore requires an exemption. An equivalent level of safety will be achieved by monitoring the battery through the ground station and landing with a minimum of 30 percent battery power remaining.

14 CFR 91.203 (a) & (b) - Given the size and configuration, the UAS has no ability to carry a flight manual on the aircraft. There is no room, capacity, or pilot on board to adequately carry a flight manual. An equivalent level of safety will be maintained by keeping the flight manual at the ground station where the UAS pilot will have immediate access to it.

Given the following sections only apply to aircraft with an airworthiness certificate, these sections do not apply to this applicant. As a safety precaution, the operator will perform preflight inspections and ensure UAS is in working condition before initiating each flight:

- **14 CFR 91.405 (a)**
- **14 CFR 91.407 (a)(1)**
- **14 CFR 91.409 (a)(1) & (a)(2)**
- **14 CFR 91.417 (a) & (b)**

Equivalent Level of Safety

In addition to the safety standards mentioned above the UAS will adhere to the following additional guidelines:

1. The UAS will not be operated within 5 miles of an airport unless prior contact to Air Traffic Control has been established.
2. Flights will not exceed the an airspeed of 36 mph (31.3 knots)
3. Flights will be operated at or below an altitude never exceeding 400 feet AGL.
4. The PIC and VO will communicate verbally at all times.
5. UAS operations will not be conducted during night.
6. All operations will be conducted under visual meteorological conditions.
7. The UAS will land with a minimum 30 percent battery reserve remaining.
8. The UAS will only be piloted within visual line of sight.
9. The UAS will utilize an internal flight safety feature that will return to a preprogrammed position and land if communication with the remote control is lost.

10. Preflight inspections and protocol will be followed prior to all operations.
11. The UAS will abort flight in the event of unpredictable obstacles or emergencies.

Public Interest

We believe the use of a UAS in lieu of a manned aircraft would enhance safety and reduce the environmental impact compared to similar operations conducted with a manned aircraft carrying a crew and flammable fuel.

The inspections of cellular communication towers or similar structures will eliminate the risks associated with persons attempting to climb these structures. The photographs and video collected will provide engineers with valuable information as to the safety of these structures.

The use of a UAS in the real estate industry provides both the buyer and seller with a higher level of marketing and service. The UAS is able to provide a view which encompasses the entire property in a single photo or short video clip. When compared to similar operations, utilizing a UAS poses much less of a safety concern for the general public with less fuel, time, noise and other resources.

Privacy

All flights will occur over private or controlled areas with the owner's consent. Capturing people in images will rarely occur. If a person is captured in a collected image they will have consented prior to filming or otherwise have agreed to being in the area prior to the filming taking place.

Sincerely,

A handwritten signature in black ink, appearing to read "Ryan A Koverman", with a long, sweeping horizontal line extending to the right.

Ryan A Koverman
President

PHANTOM 3

PROFESSIONAL

User Manual (V1.0)

2015.04

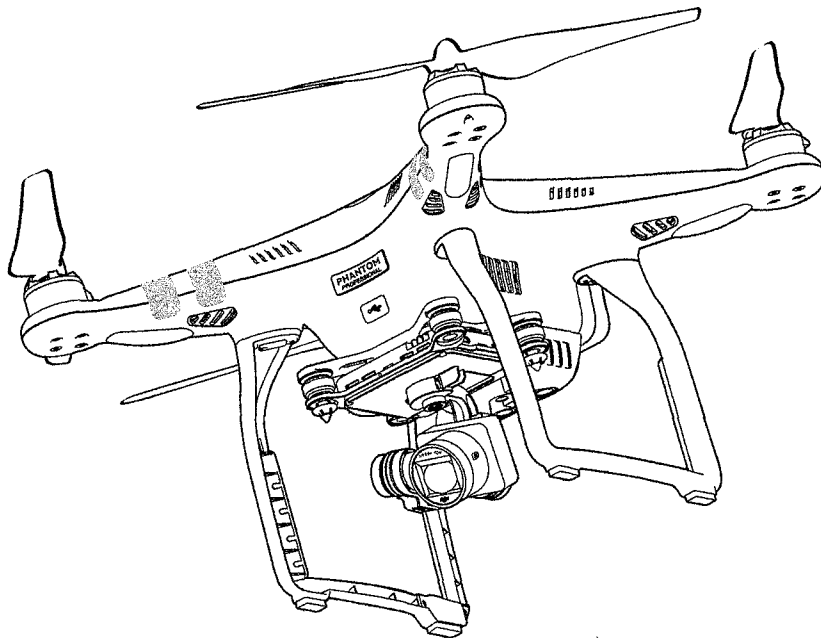

Using this manual

Legends

 Warning

 Important

 Hints and Tips

 Reference

Read Before the First Flight

Read the following documents before using the Phantom 3 Professional:

1. *In the Box*
2. *Phantom 3 Professional User Manual*
3. *Phantom 3 Professional Quick Start Guide*
4. *Phantom 3 Professional / Advanced Safety Guidelines and Disclaimer*
5. *Phantom 3 Professional / Advanced Intelligent Flight Battery Safety Guidelines*

We recommend that you watch all tutorial videos on the official DJI website and read the Disclaimer before you fly. Prepare for your first flight by reviewing the Phantom 3 Professional Quick Start Guide and refer to the User Manual for more detailed information.

Video Tutorials

Please watch the tutorial videos at the link below, which demonstrates how to use Phantom 3 Professional safely:

<http://www.dji.com/product/phantom-3/video>



Download the DJI Pilot app

Download and install the DJI Pilot app before using the aircraft. Scan the QR code to the right to download the latest version.

The Android version of the DJI Pilot app is compatible with Android 4.1.2 or later.
The iOS version of the DJI Pilot app is compatible with iOS 8.0 or later.



Contents

Using this manual

Legends	2
Read Before the First Flight	2
Video Tutorials	2
Download the DJI Pilot app	2

Product Profile

Introduction	6
Feature Highlights	6
Preparing the Aircraft	7
Aircraft Diagram	8
Remote Controller Diagram	8

Aircraft

Flight Controller	11
Flight Mode	11
Flight Status Indicator	11
Return-to-Home (RTH)	12
Smart RTH	12
Low Battery RTH	13
Failsafe RTH	14
Vision Positioning System	14
Flight Recorder	16
Attaching and Detaching the Propellers	16
DJI Intelligent Flight Battery	17

Remote Controller

Remote Controller Profile	23
Using the Remote Controller	23
Remote Controller Status LED	27
Linking the Remote Controller	28
Remote Controller Compliance Version	29

Camera and Gimbal

Camera Profile	31
Gimbal	32

DJI Pilot App

Camera	35
Director	38
Store	38
Discovery	38

Flight

Flight Environment Requirements	40
Flight Limits and No-Fly Zones	40
Preflight Checklist	44
Calibrating the Compass	44
Auto Takeoff and Auto Landing	45
Flight Test	46
Starting/Stopping the Motors	46

Troubleshooting (FAQ)

Appendix

Specifications	53
Intelligent Orientation Control (IOC)	55
FCC Compliance	56

Product Profile

This section introduces the Phantom 3 Professional and lists the components of the aircraft and remote controller.

Product Profile

Introduction

The Phantom 3 Professional represents the next generation of DJI quadcopters. It is capable of capturing 4K video and transmitting an HD video signal out of the box. The built-in camera has an integrated gimbal to maximize stability while minimizing both weight and size. Even when no GPS signal is available, the Vision Positioning System allows the aircraft to hover accurately in place.

Feature Highlights

Camera and Gimbal: With the Phantom 3 Professional, you're shooting 4K video at up to 30 frames per second and capturing 12 megapixel photos that look crisper and cleaner than ever. An enhanced sensor gives you greater clarity, lower noise, and better pictures than any previous flying camera.

HD Video Downlink: The low-latency long range HD downlink is powered by an enhanced version of DJI Lightbridge.

DJI Intelligent Flight Battery: The 4480 mAh DJI Intelligent Flight Battery features upgraded battery cells and an advanced power management system.

Flight Controller: The next-generation flight controller has been updated to provide a safer, more reliable flight experience. A newly implemented flight recorder stores critical data from each flight and the Vision Positioning System enhances hovering precision when flying indoors or in environments where GPS is unavailable.

Preparing the Aircraft

Removing Gimbal Clamp

Remove the gimbal clamp by sliding it to the right (when facing the nose of the aircraft), as shown below.

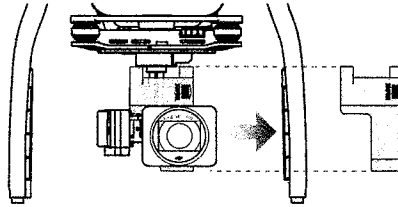

Attaching the Propellers:

Mount the propellers with black dots on to motors with black axes and spin counter-clockwise to secure. Mount the propellers with silver dots on to motors with silver axes and spin clockwise to secure. Be sure all propellers are securely in place.

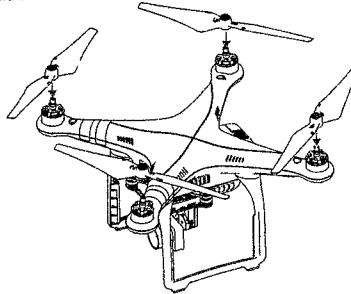

⚠ Place all propellers onto the correct motors and tighten by hand to lock them in position.

Preparing the Remote Controller:

The mobile device holder is designed for securing tablet or mobile device. Tilt the mobile device holder to the desired position, then adjust the antennas so they are facing outward.

1. Press the button on the top right side of the mobile device holder to release the clamp, then adjust the clamp to fit the size of your mobile device.
2. Secure your mobile device in the clamp by pressing down, and connect your mobile device to the remote controller using a USB cable.
3. Plug one end of the cable into the mobile device, and the other end into the USB port on the back of the remote controller.

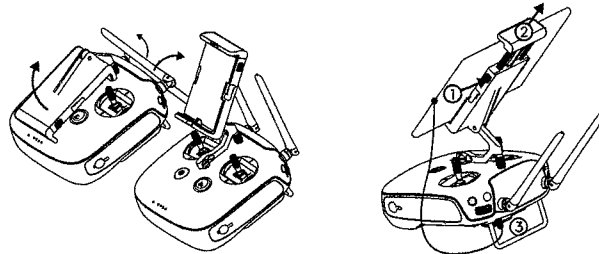

Aircraft Diagram

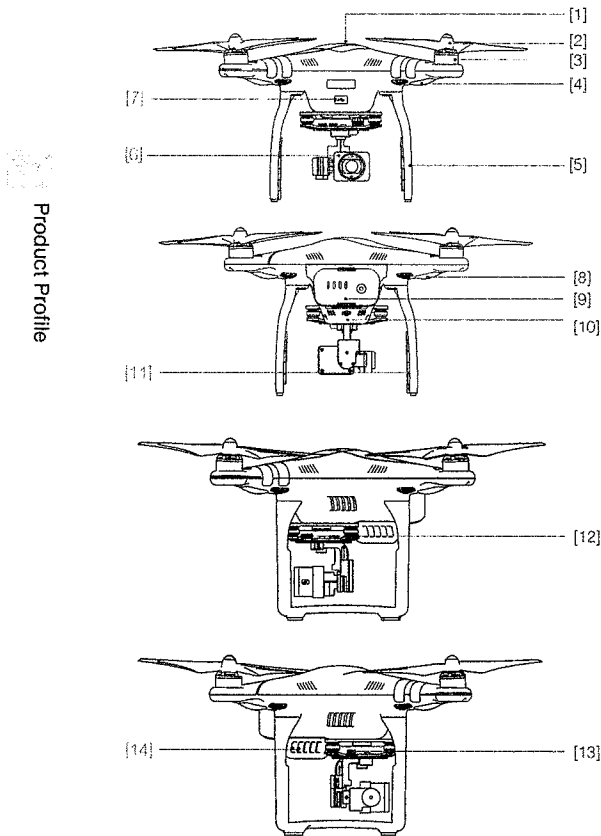

Product Profile

- [1] GPS
- [2] Propeller
- [3] Motor
- [4] Front LED Indicator
- [5] Landing gear
- [6] Gimbal and Camera
- [7] Aircraft Micro-USB Port
- [8] Aircraft Status Indicator
- [9] Intelligent Flight Battery
- [10] Vision Positioning Sensors
- [11] Antennas
- [12] Camera Micro-SD Card Slot
- [13] Camera Micro-USB Port
- [14] Link Button

Remote Controller Diagram

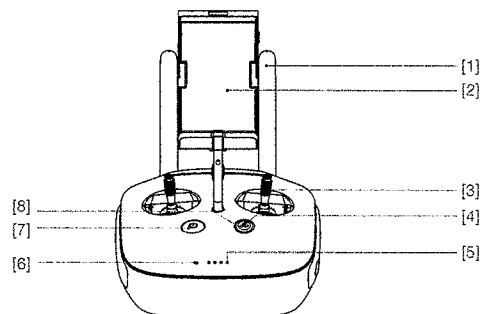

- [1] Antennas
Relays aircraft control and video signal.
- [2] Mobile Device Holder
Securely mounts your mobile device to the remote controller.
- [3] Control Stick
Controls the orientation and movement of the aircraft.
- [4] Return Home (RTH) Button
Press and hold the button to initiate Return to Home (RTH).

- [5] **Battery Level LEDs**
Displays the battery level of the remote controller.
- [6] **Status LED**
Displays the remote controller's system status.
- [7] **Power Button**
Used to turn the remote controller on and off.
- [8] **RTH LED**
Circular LED around the RTH button displays RTH status.

- [9] **Camera Settings Dial**
Turn the dial to adjust camera settings. (Only functions when the remote controller is connected to a mobile device running the DJI Pilot app.)
- [10] **Playback Button**
Playback the captured images or videos. (Only functions when the remote controller is connected to a mobile device running the DJI Pilot app.)
- [11] **Shutter Button**
Press to take a photo. If burst mode is selected, the set number of photos will be taken with one press.
- [12] **Flight Mode Switch**
Switch between P-mode, A-mode, and F-mode.
- [13] **Video Recording Button**
Press to start recording video. Press again to stop recording.

- [17] **C1 Button**
Customizable through the DJI Pilot app.
- [18] **C2 Button**
Customizable through the DJI Pilot app.
- [19] **Power Port**
Connect to the DJI Phantom 3 Charger to charge the battery of the remote controller.

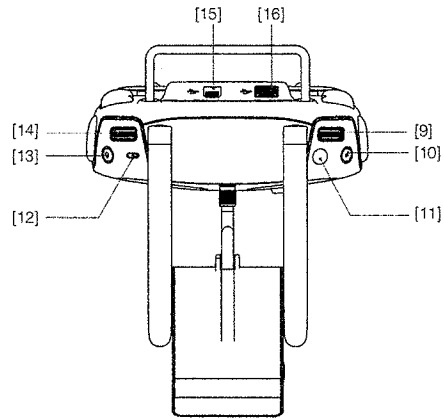

- [14] **Gimbal Dial**
Use this dial to control the tilt of the gimbal.
- [15] **Micro-USB Port**
Connect to a SD card reader to upgrade the firmware.
- [16] **USB Port**
Connect to mobile device or to a USB port for firmware upgrade.

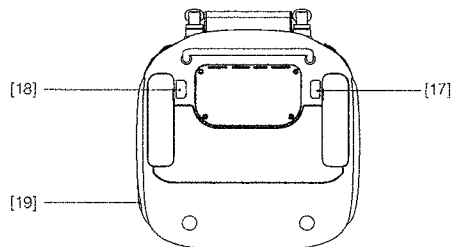

Aircraft

This section introduces the features of the Flight Controller, Vision Positioning System, and the Intelligent Flight Battery

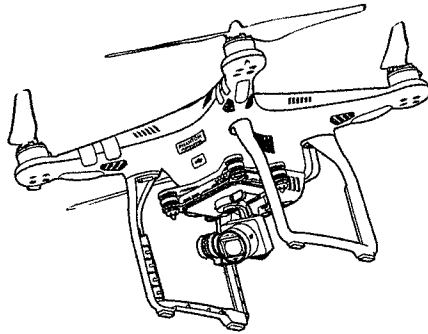

Aircraft

Flight Controller

The Phantom 3 Professional's flight controller features several important upgrades, including a new flight mode. Safety modes include Failsafe and Return-to-Home. These features ensure the safe return of your aircraft if the control signal is lost. The flight controller can also save critical flight data from each flight to the on-board storage device. The new flight controller also provides increased stability and a new air braking feature.

Flight Mode

Three flight modes are available. The details of each flight mode are found below:

P-mode (Positioning) : P-mode works best when GPS signal is strong. There are three different states of P-mode, which will be automatically selected by the Phantom 3 Professional depending on signal strength of GPS and Vision Positioning sensors :

P-GPS: GPS and Vision Positioning both are available. The aircraft is using GPS for positioning.

P-OPTI: Vision Positioning is available but the GPS signal strength is not sufficient. The aircraft is using only the Vision Positioning System for positioning.

P-ATTI: Neither GPS nor Vision Positioning is available. The aircraft is using only its barometer for positioning, so only altitude can be stabilized.

A-mode (Attitude): GPS and Vision Positioning System are not used for stabilization. The aircraft only uses its barometer. The aircraft can still automatically return to the home point if the control signal is lost and the Home Point was recorded successfully.

F-mode (Function): Intelligent Orientation Control (IOC) is activated in this mode. For more information about IOC, refer to the IOC section in the Appendix.

 Use the Flight Controller mode switch to change the flight mode of the aircraft, refer to the "Flight Mode Switch" on Page 26 for more information.

Flight Status Indicator

The Phantom 3 Professional has Front LEDs and Aircraft Status Indicators. The positions of these LEDs are shown in the figure below:

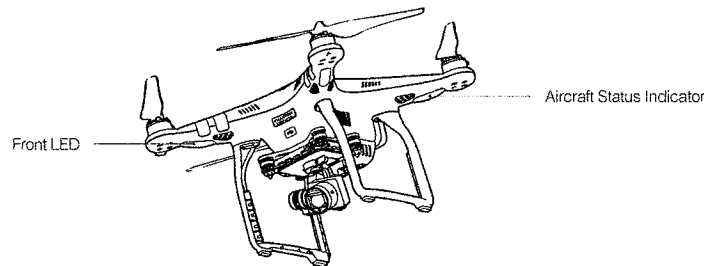

The Front LEDs show the orientation of the aircraft. The Front LEDs glow solid red when the aircraft is turned on to indicate the front (or nose) of the aircraft. The Aircraft Status Indicators communicate the system status of the flight controller. Refer to the table below for more information about the Aircraft Status Indicators:

Aircraft Status Indicator Description

Normal



R-G-Y Red, Green and Yellow Flash Alternately	Turning On and Self Diagnostic Testing
G-Y Green and Yellow Flash Alternately	Warming Up
G Green Flashes Slowly	Safe to Fly (P-mode with GPS and Vision Positioning)
G X2 Green Flashes Twice	Safe to Fly (P-mode with Vision Positioning but without GPS)
Y Yellow Flashes Slowly	Safe to Fly (A-mode but No GPS and Vision Positioning)

Warning

Y Fast Yellow Flashing	Remote Controller's Signal Lost
R Slow Red Flashing	Low Battery Warning
R Fast Red Flashing	Critical Battery Warning
R Red Flashing Alternately	IMU Error
R — Solid Red	Critical Error
R-Y Red and Yellow Flash Alternately	Compass Calibration Required

Return-to-Home (RTH)

The Return-to-Home (RTH) function brings the aircraft back to the last recorded Home Point. There are three types of RTH procedures: Smart RTH, Low Battery RTH, and Failsafe RTH. This section describes these three scenarios in detail.

	GPS	Description
Home Point		If a strong GPS signal was acquired before takeoff, the Home Point is the location from which the aircraft was launched. The GPS signal strength is indicated by the GPS icon (). The aircraft status indicator will blink rapidly when the home point is recorded.

Smart RTH

Use the RTH button on the remote controller (refer to "RTH button" on page 26 for more information) or tap the RTH button in the DJI Pilot app and follow the on-screen instructions when GPS is available to initiate Smart RTH. The aircraft will then automatically return to the last recorded Home Point. You may use the remote controller's control sticks to control the aircraft's position to avoid a collision during the Smart RTH process. Press and hold the Smart RTH button once to start the process, and press the Smart RTH button again to terminate the procedure and regain full control of the aircraft.

Low Battery RTH

The low battery level failsafe is triggered when the DJI Intelligent Flight Battery is depleted to a point that may affect the safe return of the aircraft. Users are advised to return home or land the aircraft immediately when prompted. The DJI Pilot app will display a notice when a low battery warning is triggered. The aircraft will automatically return to the Home Point if no action is taken after a ten-second countdown. The user can cancel the RTH procedure by pressing the RTH button on the remote controller. The thresholds for these warnings are automatically determined based on the aircraft's current altitude and distance from the Home Point.

The aircraft will land automatically if the current battery level can only support the aircraft long enough to descend from its current altitude. The user can still use the remote controller to alter the aircraft's orientation during the landing process.

The Battery Level Indicator is displayed in the DJI Pilot app, and is described below:

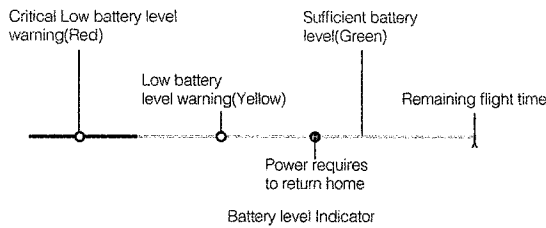

Battery Level Warning	Remark	Aircraft Status Indicator	DJI Pilot app	Flight Instructions
Low battery level warning	The battery power is low. Please land the aircraft.	Aircraft status indicator blinks RED slowly.	Tap "Go-home" to have the aircraft return to the Home point and land automatically, or "Cancel" to resume normal flight. If no action is taken, the aircraft will automatically go home and land after 10 seconds. Remote controller will sound an alarm.	Fly the aircraft back and land it as soon as possible, then stop the motors and replace the battery.
Critical Low battery level warning	The aircraft must land immediately.	Aircraft status indicator blinks RED quickly.	The DJI Pilot app display will flash red and the aircraft will start to descend. The remote controller will sound an alarm.	Allow the aircraft to descend and land automatically.
Estimated remaining flight time	Estimated remaining flight based on current battery level.	N/A	N/A	N/A

Aircraft

- When Critical battery level warning is triggered and the aircraft begins to land automatically, you may push the throttle upward to make the aircraft hover at its current altitude, giving you an opportunity to navigate to a more appropriate landing location.
- The colored zones and markers on the battery level indicator bar reflect the estimated remaining flight time. They are automatically adjusted according to the aircraft's current location and status.

Failsafe RTH

If the Home Point was successfully recorded and the compass is functioning normally, Failsafe RTH will be automatically activated if the remote controller signal is lost for more than three seconds. The Return-to-Home process may be interrupted and the operator may regain control of the aircraft if the remote controller signal connection is re-established.

Failsafe Illustration

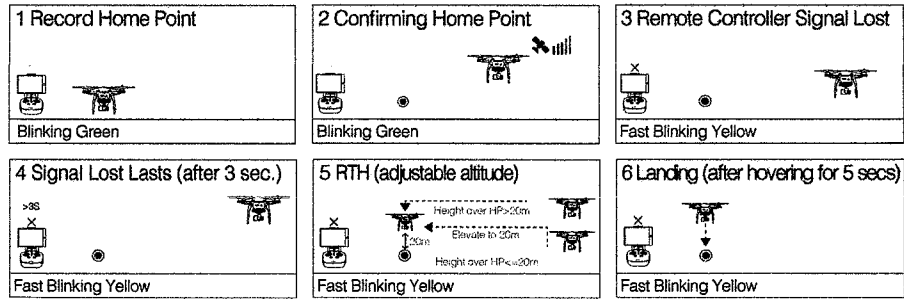

- The aircraft cannot avoid obstruction during the Failsafe RTH, therefore, it is important to set a suitable Failsafe altitude before each flight. Launch the DJI Pilot app and enter "Camera" and select "MODE > Advanced Settings > Failsafe mode" to set the Failsafe altitude.
- The aircraft will stop its ascent and return to the Home Point immediately if the throttle stick is moved during the Failsafe RTH procedure.

Vision Positioning System

The DJI Vision Positioning System uses ultrasound and image data to help the aircraft maintain its current position. With the help of Vision Positioning, your Phantom 3 Professional can hover in place more precisely and fly indoors or in other environments where a GPS signal is not available. The main components of the Vision Positioning System are located on the bottom of your Phantom 3 Professional; they include [2] two ultrasonic sensors and [1] one monocular camera.

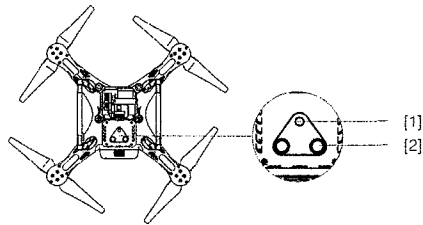

Using Vision Positioning

Vision Positioning is activated automatically when the Phantom 3 Professional is turned on. No further action is required. Vision Positioning is typically used in indoor environments, where GPS is unavailable. Using the sensors that are built into the Vision Positioning system, the Phantom 3 Professional can hover precisely even without GPS.

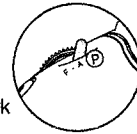
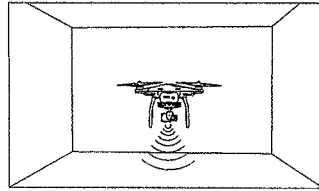

Aircraft

Follow the steps below to use Vision Positioning:

1. Toggle the flight mode switch to P-mode.
2. Place the aircraft on a flat surface. Note that the Vision Positioning system cannot work properly on surfaces without clear pattern variations.
3. Turn on the aircraft. The aircraft status indicator will flash green two times, which indicates the Vision Positioning system is ready. Gently push the throttle up to lift off and the aircraft will hover in place.

⚠ The performance of your Vision Positioning System is affected by the surface over which it is flying. The ultrasonic sensors may not be able to accurately measure distances when operating above sound-absorbing materials. In addition, the camera may not function correctly in suboptimal environments. The aircraft will switch from P-mode to A-mode automatically if neither GPS nor Vision Positioning System are available. Operate the aircraft with great caution in the following situations:

- Flying over monochrome surfaces (e.g. pure black, pure white, pure red, pure green).
- Flying over a highly reflective surfaces.
- Flying at high speeds (over 8 m/s at 2 meters or over 4 m/s at 1 meter).
- Flying over water or transparent surfaces.
- Flying over moving surfaces or objects.
- Flying in an area where the lighting changes frequently or drastically.
- Flying over extremely dark (lux < 10) or bright (lux > 100,000) surfaces.
- Flying over surfaces that can absorb sound waves (e.g. thick carpet).
- Flying over surfaces without clear patterns or texture.
- Flying over surfaces with identical repeating patterns or textures (e.g. tiles with the same design).
- Flying over inclined surfaces that will deflect sound waves away from the aircraft.

- 💡**
 - Keep the sensors clean at all times. Dirt or other debris may adversely affect the effectiveness of the sensors.
 - Vision Positioning is only effective when the aircraft is at altitudes of 0.3 to 3 meters.
 - The Vision Positioning System may not function properly when the aircraft is flying over water.
 - The Vision Positioning System may not be able to recognize pattern on the ground in low light conditions (less than 100 lux).
 - Do not use other ultrasonic devices with frequency of 40 KHz when Vision Positioning system is in operation.
 - Vision Positioning System may not be able to stabilize the aircraft when flying close to the ground (below 0.5 meters) at fast speeds..

- ⊘ Keep the animals away from the aircraft when Vision Positioning system is activated. The sonar sensor emits high frequency sounds that are only audible to some animals.





Flight Recorder

Flight data is automatically recorded to the internal storage of the aircraft. This includes flight telemetry, aircraft status information, and other parameters. To access these data, connect the aircraft to the PC through the Micro-USB port and launch the DJI Pilot app.

Attaching and Detaching the Propellers

Use only DJI approved propellers with your Phantom 3 Professional. The grey and black nuts on the propeller indicate where they should be attached and in which direction they should spin. To attach the propellers properly, match the nut color with the motor axis color.

Aircraft

Propellers	Silver Dot	Black Dot
Figure		
Attach On	Motors with a grey axes	Motors with a black axes
Legends	 Lock : Turn the propellers in the indicated direction to mount and tighten.  Unlock : Turn the propellers in the indicated direction to loosen and remove.	

Attaching the Propellers

1. Be sure to remove the warning stickers from the motors before attaching the propellers.
2. Attach the propellers with silver dots onto the motors with silver axes and spin the propellers clockwise to secure them in place. Attach the propellers with black dots onto the motors with black axes and spin the propellers counter-clockwise to secure them in place. Be sure to tighten each propeller by hand before flight.

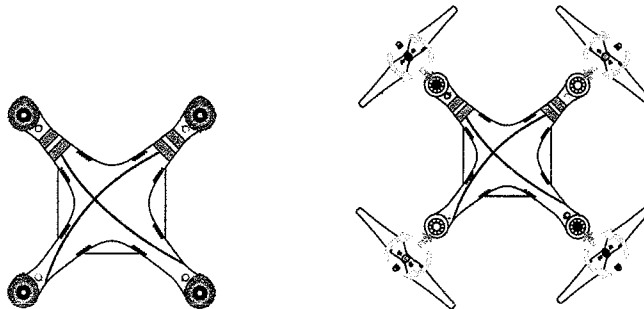

- ⚠ • Ensure propellers are attached to its corresponding motors, otherwise the aircraft cannot take off.
- Wear gloves when handling propellers.
- Hand tighten each of the propellers on the corresponding motors to ensure it is attached firmly.

Detaching the Propellers

Hold the motor in place with one hand, then spin the propeller in the indicated unlock direction.

- ⚠ • Check that the propellers and motors are installed correctly and firmly before every flight.
- Ensure that all propellers are in good condition before each flight. DO NOT use aged, chipped, or broken propellers.
- To avoid injury, STAND CLEAR of and DO NOT touch propellers or motors when they are spinning.
- ONLY use original DJI propellers for a better and safer flight experience.

DJI Intelligent Flight Battery

The DJI Intelligent Flight Battery has a capacity of 4480 mAh, a voltage of 15.2 V, and a smart charge/discharge functionality. It should only be charged using an appropriate charger that has been approved by DJI.

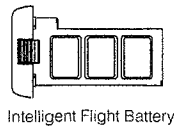

Intelligent Flight Battery

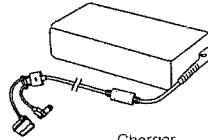

Charger

- ⚠ The Intelligent Flight Battery must be fully charged before using it for the first time. Refer to "Charging the Intelligent Flight Battery" for more information.
- 💡 Be aware that the output power of the supplied Phantom 3 Professional charger is 100W.

DJI Intelligent Flight Battery Functions

1. Battery Level Display: the LED indicators display the current battery level.
2. Battery Life Display: the LEDs display the current battery power cycle.
3. Auto-Discharging Function: To prevent swelling, the battery automatically discharges to below 65% of total power when it is idle for more than ten days. It takes around two days to discharge the battery to 65%. It is normal to feel moderate heat being emitted from the battery during the discharge process. Discharge thresholds can be set in the DJI Pilot app.
4. Balanced Charging: Automatically balances the voltage of each battery cell when charging.
5. Overcharge Protection: Charging automatically stops when the battery is fully charged.
6. Temperature Detection: The battery will only charge when the temperature is between 0°C (32°F) and 40°C (104°F).
7. Over Current Protection: The battery stops charging when high amperage (more than 8 A) is detected.
8. Over Discharge Protection: To prevent over-discharge damage, discharging automatically stops when the battery voltage reaches 12 V.
9. Short Circuit Protection: Automatically cuts the power supply when a short circuit is detected.

10. Battery Cell Damage Protection: The DJI Pilot app displays a warning message when a damaged battery cell is detected.
11. Battery Error History: Browse the battery error history in the DJI Pilot app.
12. Sleep Mode: To save power, the battery enters sleep mode after 20 minutes of inactivity.
13. Communication: Information pertaining to the battery's voltage, capacity, current, etc. is transmitted to the aircraft's main controller.

⚠ Refer to *Phantom 3 Professional / Advanced Intelligent Flight Battery Safety Guidelines* before use. Users take full responsibility for all operations and usage.

Aircraft

Using the Battery

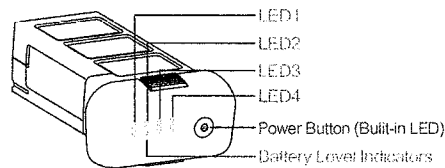

Turning ON/OFF

Turning On: Press the Power Button once, then press again and hold for 2 seconds to turn on. The Power LED will turn red and the Battery Level Indicators will display the current battery level.

Turning Off: Press the Power Button once, then press again and hold for 2 seconds to turn off. The battery power LED will flash when powering off the Phantom to allow automatically stopping of a recording during the event recording wasn't stopped.

Low Temperature Notice:

1. Battery capacity is significantly reduced when flying in low temperature ($< 0^{\circ}\text{C}$) environments.
2. It is not recommended that the battery be used in extremely low temperature ($< -10^{\circ}\text{C}$) environments. Battery voltage should reach the appropriate level when operating environment with temperatures between -10°C and 5°C .
3. End the flight as soon as the DJI Pilot app displays the "Low Battery Level Warning" in low temperature environments.
4. Keep the battery indoors to warm it before flying in low temperature environments.
5. To ensure optimal performance of the battery, keep the battery temperature above 20°C .
6. The charger will stop charging the battery if the battery cell's temperature is not within the operating range ($0^{\circ}\text{C} \sim 40^{\circ}\text{C}$).





































⚠ In cold environments, insert the battery into the battery compartment and allow the aircraft for approximately 1-2 minutes to warm up before taking off.

Checking the Battery Level

The Battery Level Indicators display how much power remains. When the battery is turned off, press the Power Button once. The Battery Level Indicators will light up to display the current battery level. See below for details.

 The Battery Level Indicators will also show the current battery level during charging and discharging. The indicators are defined below.





































 : LED is on.  : LED is flashing.
 : LED is off.

Battery Level					Battery Level
LED1	LED2	LED3	LED4		
					87.5%~100%
					75%~87.5%
					62.5%~75%
					50%~62.5%
					37.5%~50%
					25%~37.5%
					12.5%~25%
					0%~12.5%
					=0%

Aircraft

Battery life

Battery life refers to how many more times the battery can be discharged and recharged before it must be replaced. When the battery is turned off, press and hold the Power Button for 5 seconds to check the battery life. The Battery Level Indicators will light up and/or blink for two seconds, as shown below:

Battery Life					Battery Life
LED1	LED2	LED3	LED4		
					90%~100%
					80%~90%
					70%~80%
					60%~70%
					50%~60%
					40%~50%
					30%~40%
					20%~30%
					below 20%

 When battery life reaches 0%, it can no longer be used.

 For more information about the battery, launch the DJI Pilot app and check the information that is listed under the battery tab.

Charging the Intelligent Flight Battery

1. Connect the Battery Charger to a power source (100-240 V 50/60 Hz).
2. Open the Protection Cap and connect the Intelligent Flight Battery to the Battery Charger. If the battery level is above 95%, turn on the battery before charging.
3. The Battery Level Indicator will display the current battery level as it is charging.
4. The Intelligent Flight Battery is fully charged when the Battery Level Indicators are all off.
5. Air-cool the Intelligent Flight Battery after each flight. Allow its temperature to drop to room temperature before storing it for an extended period.

- ⚠ • We do not recommend charging the Intelligent Flight Battery and remote controller with the standard charger at the same time, otherwise the charger may overheat.
- Always turn off the battery before inserting it or removing it from the Phantom 3 Professional. Never insert or remove a battery when it is turned on.

Aircraft

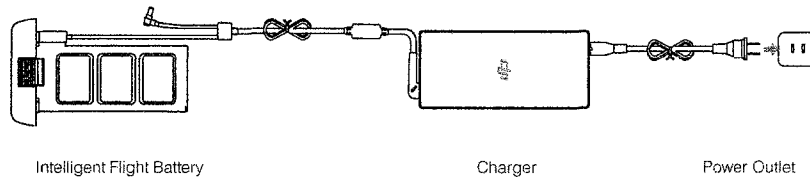

Battery Level Indicators While Charging

LED1	LED2	LED3	LED4	Battery Level
☐	☐	☐	☐	0%~25%
☐	☐	☐	☐	25%~50%
☐	☐	☐	☐	50%~75%
☐	☐	☐	☐	75%~100%
☐	☐	☐	☐	Fully Charged

Battery Protection LED Display

The table below shows battery protection mechanisms and corresponding LED patterns.

Battery Level Indicators while Charging

LED1	LED2	LED3	LED4	Blinking Pattern	Battery Protection Item
☐	☐	☐	☐	LED2 blinks twice per second	Over current detected
☐	☐	☐	☐	LED2 blinks three times per second	Short circuit detected
☐	☐	☐	☐	LED3 blinks twice per second	Over charge detected
☐	☐	☐	☐	LED3 blinks three times per second	Over-voltage charger detected
☐	☐	☐	☐	LED4 blinks twice per second	Charging temperature is too low
☐	☐	☐	☐	LED4 blinks three times per second	Charging temperature is too high

After these issues are resolved, press the Power Button to turn off the Battery Level Indicator. Unplug the Intelligent Flight Battery from the charger and plug it back in to resume charging. Note that you do not need to unplug and plug in the charger in the event of a room temperature error; the charger will resume charging when the temperature is within the allowable range.

 DJI does not take any responsibility for damage caused by third-party chargers.

 **How to discharge your Intelligent Flight Battery:**

Slow : Place the Intelligent Flight Battery into the Phantom 3 Professional's Battery Compartment and turn it on. Leave it on until there is less than 8% of power left, or until the battery can no longer be turned on. Launch the DJI Pilot app to check battery levels.

Rapid : Fly the Phantom 3 Professional outdoors until there is less than 8% of power left, or until the battery can no longer be turned on.

Remote Controller

This section describes the features of the remote controller and includes instructions for controlling the aircraft and the camera.

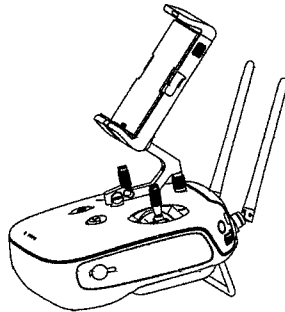

Remote Controller

Remote Controller Profile

The Phantom 3 Professional remote controller is a multi-function wireless communication device that integrates the video downlink system and aircraft remote control system. The video downlink and aircraft remote control system operate at 2.4 GHz. The remote controller features a number of camera control functions, such as taking and previewing photos and videos, as well as controlling gimbal motion. The remote controller is powered by a 2S rechargeable battery. The battery level is displayed via LED indicators on the front panel of the remote controller.

- **Compliance Version:** The remote controller is compliant with both CE and FCC regulations.
- **Operating Mode:** Control can be set to Mode 1 or Mode 2, or to a custom mode.
- **Mode 1:** The right stick serves as the throttle.
- **Mode 2:** The left stick serves as the throttle.

⚠ To prevent transmission interference, do not operate more than three aircrafts in the same area.

Using the Remote Controller

Turning the Remote Controller On and Off

The Phantom 3 Professional remote controller is powered by a 2S rechargeable battery that has a capacity of 6000 mAh. The battery level is indicated via the Battery Level LEDs on the front panel. Follow the steps below to turn on your remote controller:

1. When the remote controller is turned off, press the Power Button once. The Battery Level LEDs will display the current battery level.
2. Press and hold the Power Button to turn on the remote controller.
3. The remote controller will beep when it is turned on. The Status LED will rapidly blink green, indicating that the remote controller is linking to the aircraft. The Status LEDs will glow solid green when linking is complete.
4. Repeat Step 2 to turn off the remote controller.

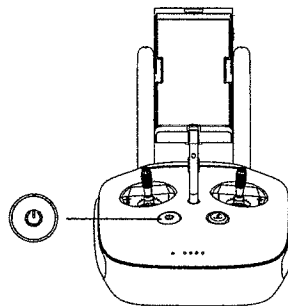

Charging the Remote Controller

Charge the remote controller using the included charger. Refer to the figure on next page below for more details.

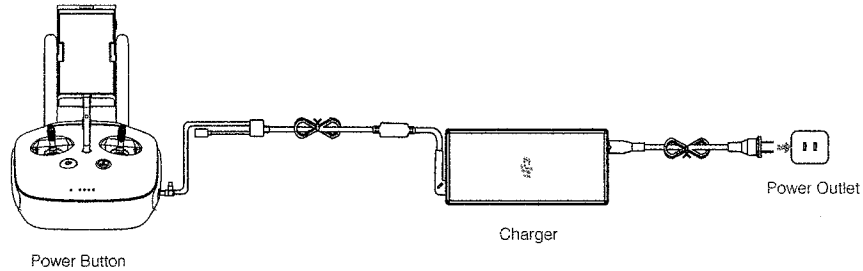

Controlling the Camera

Shoot videos/pictures, view recorded images, and adjust camera settings via the Shutter Button, Camera Settings Dial, Playback Button, and Video Recording Button on the remote controller.

Remote Controller

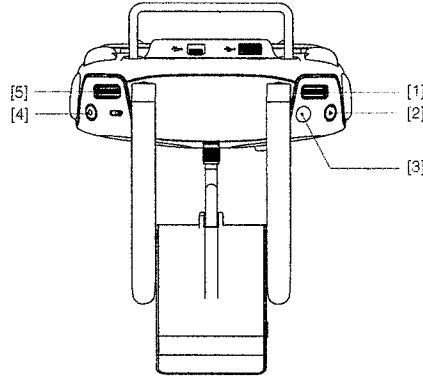

[1] Camera Settings Dial

Turn the dial to adjust camera settings such as ISO, shutter speed, and aperture without letting go of the remote controller. Move the dial to left or right to scroll through pictures and videos in playback mode. Press down on the dial to toggle between these settings.

[2] Playback Button

Press to view images and videos that have already been captured.

[3] Shutter Button

Press to take a photo. If burst mode is activated, multiple photos will be taken with a single press.

[4] Video Recording Button

Press once to start recording video, then press again to stop recording.





[5] Gimbal Dial

Use this dial to control the tilt of the gimbal.

Controlling Aircraft

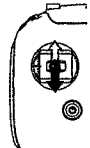
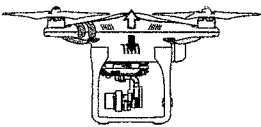
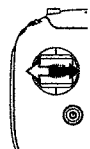
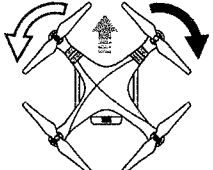
This section explains how to control the orientation of the aircraft through the remote controller. The Remote Control is set to Mode 2 by default.

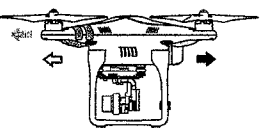
 Stick Neutral/Mid-Point: Control sticks are in the center position.
 Moving the Control Stick: The control stick is pushed away from the center position.

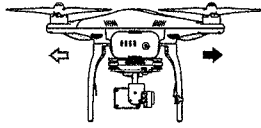
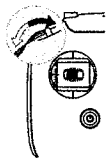
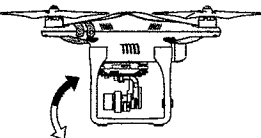
Remote Controller (Mode 2)	Aircraft (* Indicates Nose Direction)	Remarks
		Moving the left stick up and down changes the aircraft's elevation. Push the stick up to ascend and down to descend. When both sticks are centered, the Phantom 3 Professional will hover in place. The more the stick is pushed away from the center position, the faster the Phantom 3 Professional will change elevation. Always push the stick gently to prevent sudden and unexpected elevation changes.
		Moving the left stick to the left or right controls the rudder and rotation of the aircraft. Push the stick left to rotate the aircraft counter-clockwise, push the stick right to rotate the aircraft clockwise. If the stick is centered, the Phantom 3 Professional will maintain its current orientation. The more the stick is pushed away from the center position, the faster the Phantom 3 Professional will rotate.
		Moving the right stick up and down changes the aircraft's forward and backward pitch. Push the stick up to fly forward and down to fly backward. Phantom 3 Professional will hover in place if the stick is centered. Push the stick further away from the center position for a larger pitch angle (maximum 30°) and faster flight.
		Moving the right stick control left and right changes the aircraft's left and right pitch. Push left to fly left and right to fly right. The Phantom 3 Professional will hover in place if the stick is centered.
		Gimbal Dial: Turn the dial to the right, and the camera will shift to point upwards. Turn the dial to the left, and the camera will shift to point downwards. The camera will remain in its current position when dial is static.

Remote Controller

Flight Mode Switch

Toggle the switch to select the desired flight mode. You may choose between; P-mode, F-mode and A-mode.

Position	Figure	Flight Mode
Position 1		F-mode
Position 2		A-mode
Position 3		P-mode

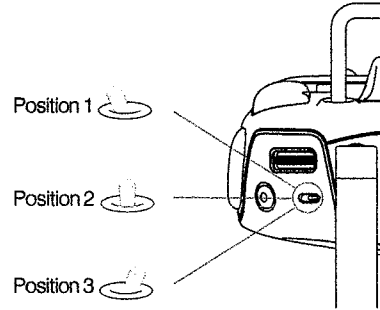

Remote Controller

P-mode (Positioning): P-mode works best when the GPS signal is strong. There are three different versions of P-mode, which will be automatically selected by the Phantom 3 Professional depending on GPS signal strength and the Vision Positioning sensors:

- P-GPS: GPS and Vision Positioning both are available; the aircraft is using GPS for positioning.
- P-OPTI: Vision Positioning is available but a sufficient GPS signal is not available. Aircraft is using only Vision Positioning for position holding.
- P-ATTI: Neither GPS nor Vision Positioning is available, the aircraft is using only its barometer for positioning, so only altitude is maintained.

A-mode (Attitude): GPS and Vision Positioning System are not used for stabilization. The aircraft uses only its barometer to stabilize. The aircraft can automatically return to the Home Point if remote controller signal is lost and the Home Point was recorded successfully.

F-mode (Function): Intelligent Orientation Control (IOC) is activated in this mode. For more information about IOC, refer to the IOC section in the Appendix.

By default, the Flight Mode Switch is locked to P-mode. To unlock other flight modes, launch the DJI Pilot app, enter the "Camera" page, and tap "Mode", then activate "Multiple Flight Mode".

RTH Button

Press and hold the RTH button to start the Return-to-Home (RTH) procedure. The LED ring around the RTH Button will blink white to indicate that the aircraft is entering RTH mode. The aircraft will then return to the last recorded Home Point. Press this button again to cancel the RTH procedure and regain control of the aircraft.

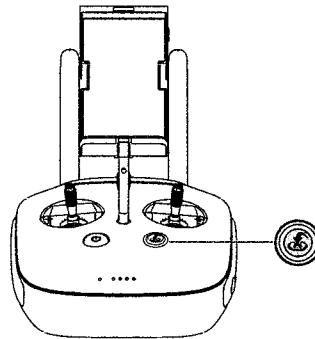

Connecting Your Mobile Device

Tilt the mobile device holder to the desired position. Press the button on the side of the mobile device holder to release the clamp, and then place your mobile device into the cradle. Adjust the clamp down to secure the mobile device. To connect your mobile device to the remote controller using a USB cable, plug one end of the cable into your mobile device and the other end into the USB port on the back of the remote controller.

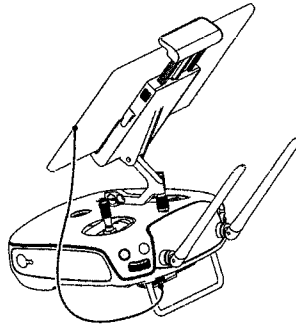

Remote Controller

Optimal Transmission Range

The transmission signal between the aircraft and the remote controller is most reliable within the area that is depicted in the image below:

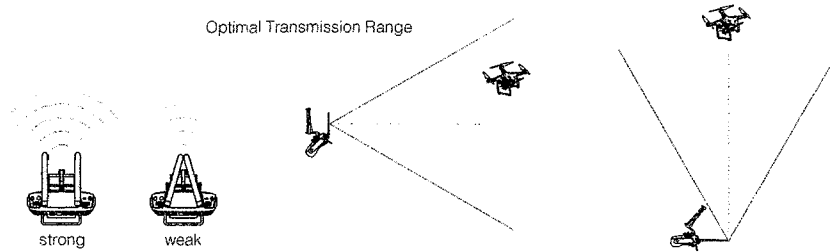

Ensure that the aircraft is flying within the optimal transmission zone. To achieve the best transmission performance, maintain the appropriate relationship between the operator and the aircraft.

Remote Controller Status LED

The Status LED reflects the strength of the connection between the remote controller and the aircraft. The RTH LED indicates the Return-to-Home status of the aircraft. The table below contains more information about these indicators.

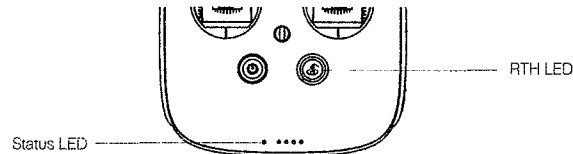

Status LED	Alarm	Remote Controller Status
R — Solid Red	♪ Chime	The remote controller is disconnected from the aircraft.
G — Solid Green	♪ Chime	The remote controller is connected to the aircraft.
R Slow Blinking Red	D-D-D.....	Remote controller error.
R G / R Y Red and Green/ Red and Yellow Alternate Blinks	None	HD downlink is disrupted.
RTH LED	Sound	Remote Controller Status
W — Solid White	♪ Chime	Aircraft is returning home.
W Blinking White	D . . .	Sending Return-to-Home command to the aircraft.
W Blinking White	DD	Return-to-Home procedure in progress.

 The Remote Status Indicator will blink red and sound an alert, when the battery level is critically low.

Linking the Remote Controller

The remote controller is linked to your aircraft before delivery. Linking is only required when using a new remote controller for the first time. Follow these steps to link a new remote controller:

1. Turn on the remote controller and connect to the mobile device. Launch the DJI Pilot app.
2. Turn on the Intelligent Flight Battery.
3. Enter "Camera" and tap on  and then tap "Linking RC" button as shown below.

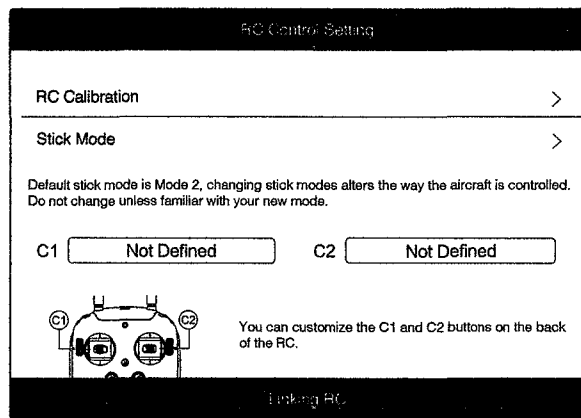

- The remote controller is ready to link. The Remote Controller Status Indicator blinks blue and a beep is emitted.

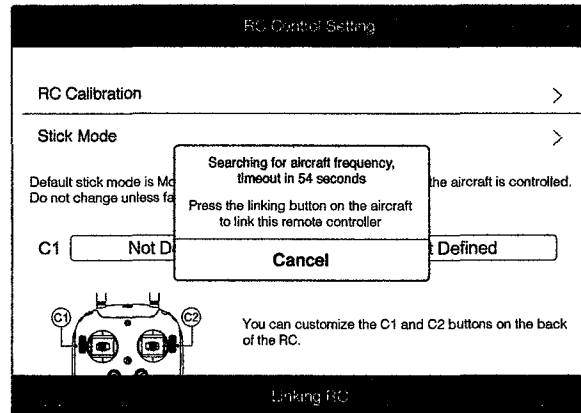

Remote Controller

- Locate the linking button on the side of the aircraft, as shown in the figure below. Press the link button to start linking. The Remote Controller Status Indicator LED will display a solid green once the remote controller is successfully linked to the aircraft.

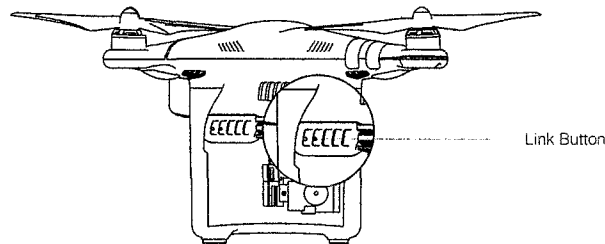

-
- ⚠ • The remote controller will un-link itself from an aircraft if a new remote controller is linked to the same aircraft.
-

Remote Controller Compliance Version

The remote controller is compliant with both CE and FCC requirements.

Camera and Gimbal

This section provides the technical specifications of the camera and explains the gimbal's operation modes.

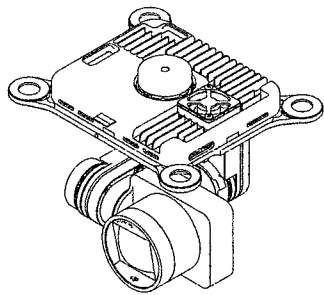

Camera and Gimbal

Camera Profile

The on-board camera uses the 1/2.3 inch CMOS sensor to capture video (up to 4096x2160p at 24fps or 4K at up to 30fps with the Phantom 3 Professional) and 12 megapixel stills. You may choose to record the video in either MOV or MP4 format. Available picture shooting modes include burst, continuous, and time-lapse mode. A live preview of what the camera sees can be monitored on the connected mobile device via the DJI Pilot app.

Camera Micro-SD Card Slot

To store your photos and videos, insert the Micro-SD card into the slot, as shown below, before turning on the Phantom 3 Professional. The Phantom 3 Professional comes with a 16 GB Micro-SD card and supports Micro-SD cards up to 64 GB. A UHS-1 Micro-SD card is recommended due to their fast read and write speeds allowing you to save high-resolution video data.

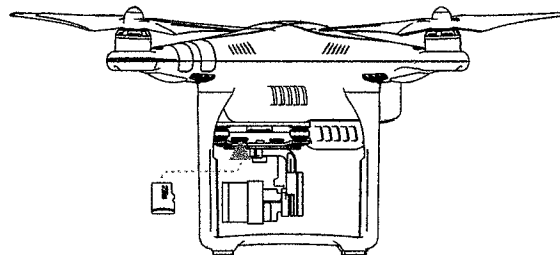

Gimbal Camera

⊘ Do not remove the Micro-SD card from the Phantom 3 Professional when it is turned on.

Camera Data Port

Turn on the Phantom 3 Professional and connect a USB cable to the Camera Data Port to download photos and videos to your computer.

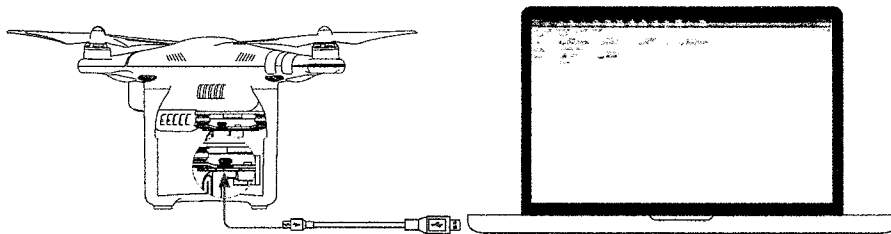

⚠ The aircraft must be turned on before attempting to access the files on the Micro-SD card.

Camera Operation

Use the Shutter and Video Recording buttons on the remote controller to shoot the images or videos through the DJI Pilot app. For more information about how to use these buttons, refer to "Controlling the Camera Page 24".

Gimbal

Gimbal Profile

The 3-axis gimbal provides a steady platform for the attached camera, allowing you to capture clear, stable images and video. The gimbal can tilt the camera within a 120° range.

Gimbal Camera

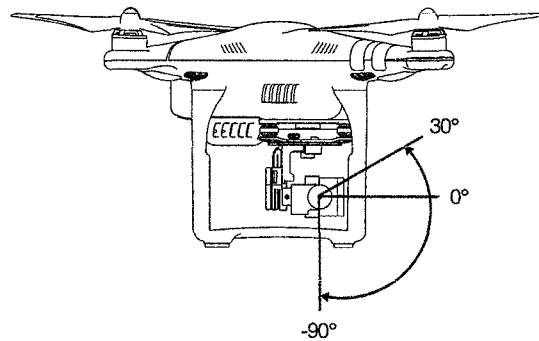

Use the gimbal dial on the remote controller to control the tilt movement of the camera.

Gimbal Operation Modes

Two gimbal operation modes are available. Switch between the different operation modes on the camera settings page of the DJI Pilot app. Note that your mobile device must be connected to the remote controller for changes to take effect. Refer to the table below for details:

	Follow Mode	The angle between gimbal's orientation and aircraft's nose remains constant at all times.
	FPV Mode	The gimbal will synchronize with the movement of the aircraft to provide a first-person perspective flying experience.

- A gimbal motor error may occur in these situations: (1) the aircraft is placed on uneven ground or the gimbal's motion is obstructed (2) the gimbal has been subjected to an excessive external force, such as a collision. Please take off from flat, open ground and protect the gimbal at all times.
- Flying in heavy fog or clouds may make the gimbal wet, leading to temporary failure. The gimbal will recover full functionality after it dries.

Anti-Drop Kit

The anti-drop kit helps keep the gimbal and camera connected to the aircraft. Two pins have been mounted prior to shipping. If new or additional pins are required, see the diagram below. Press Part ① through the hole of the vibration absorber and into the center hole of Part ②, then lock them together as shown ③. Mounting the anti-drop kit pins diagonally from each other is recommended.

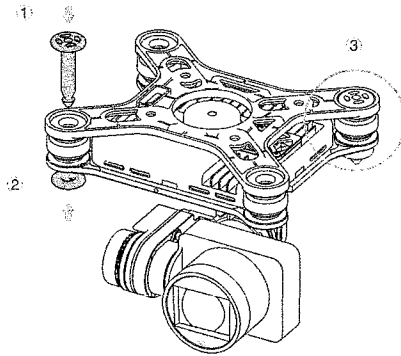

Gimbal Camera

DJI Pilot App

This section introduces the four main functions of the DJI Pilot app.

DJI Pilot App

The DJI Pilot app is a mobile application designed specifically for the Phantom 3 Professional. Use this app to control the gimbal, camera, and other aircraft functions. The app also features Map, Academy, and User Center, which are used for configuring your aircraft and sharing your photos and videos with others. It is recommended that you use a tablet for the best experience.

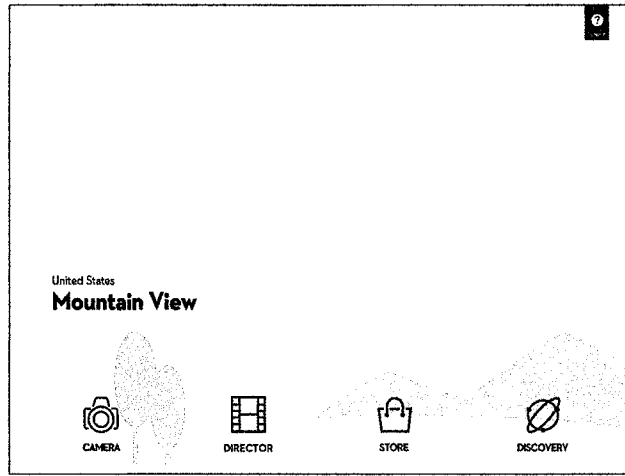

DJI Pilot App

Camera

The Camera page contains a live HD video feed from the Phantom 3 Professional's camera. You can also configure various camera parameters from the Camera page.

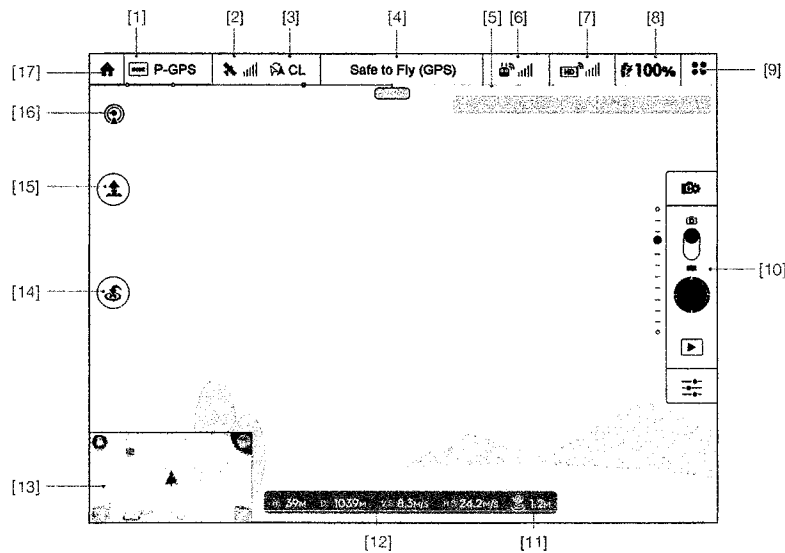

[1] Flight Mode

: The text next to this icon indicates the current flight mode.

Tap to configure the MC (Main Controller) Settings. These settings allow you to modify flight limits and set the gain values.

[2] GPS Signal Strength

: This icon shows the current strength of GPS signals. Green bars indicate adequate GPS strength.

[3] IOC Settings

 **CL**: This icon displays the IOC setting when the aircraft has entered F-mode. Tap to view the IOC settings menu and select the desired IOC setting.

[4] System Status

 **Safe to Fly (GPS)**: This icon indicates the current aircraft system status and GPS signal strength.

[5] Battery Level Indicator

: The battery level indicator provides a dynamic display of the battery level. The colored zones on the battery level indicator represent the power levels needed to carry out different functions.

[6] Remote Controller Signal

: This icon shows the strength of remote controller's signal.

[7] HD Video Link Signal Strength

: This icon shows the strength of the HD video downlink connection between the aircraft and the remote controller.

[8] Battery Level

 **100%**: This icon shows the current battery level.

Tap to view the battery information menu, set the various battery warning thresholds, and view the battery warning history.

[9] General Settings

: Tap this icon to view the General Settings page. From this page, you can set flight parameters, reset the camera, enable the quick view feature, adjust the gimbal roll value, and toggle the flight route display.

[10] Camera Operation Bar

Shutter and Recording Settings

: Tap to enter various camera value settings, including color space for the recording, resolution of the videos, image size and so on.

Shutter

: Tap this button to take a single photo. Press and hold this button to select single shot, triple shot or time-lapsed shooting modes.

Record

 : Tap once to start recording video, then tap again to stop recording. You can also press the Video Recording Button on the remote controller, which has the same functionality.

Playback

 : Tap to enter the playback page. You can preview photos and videos as soon as they are captured.

Camera Settings

 : Tap to set ISO, shutter and auto exposure values of the camera.

[11] Vision Positioning

 : This icon shows the distance between the surface and the Vision Positioning System's sensors.

[12] Flight Telemetry

The Vision Positioning Status icon is highlighted when the Vision Positioning is in operation.

Flight attitude is indicated by the flight attitude icon.

- (1) The red arrow shows which direction the aircraft is facing.
- (2) Light blue and dark blue areas indicate pitch.
- (3) The angle of the boundary between the light blue and dark blue areas indicates the roll angle.

[13] Map

Display the flight path of the current flight. Tap to switch from the Camera GUI to the Map GUI.

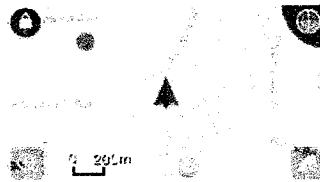
**[14] Return to Home (RTH)**

 : Initiate RTH home procedure. Tap to have the aircraft return to the last recorded home point.

[15] Auto Takeoff/Landing

 : Tap to initiate auto takeoff or landing.



DJI Pilot App

[16] Livestream

 : Livestream icon indicates the current video feed is broadcasting live on YouTube. Be sure the mobile data service is available on the mobile device.

[17] Back

 : Tap to return to the main GUI.

Director

Director is an automatic video editor built into the DJI Pilot app. After recording several video clips, simply tap "Director" from the app's home screen. You can then select a template and a specified number of clips, which are automatically combined to create a short film that can be shared immediately.

Store

Tap "Store" to visit the official DJI Online Store to see the latest information about DJI products and easily buy new products.

Discovery

Sync pictures and videos to your mobile device, view flight logs, and check your DJI account status in "Discovery". Use your registered DJI account to login to "Discovery".

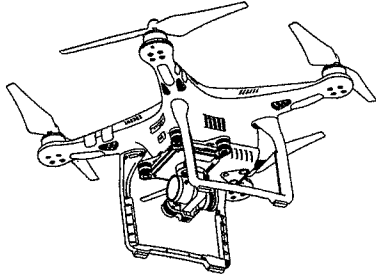

Flight

This section describes safe flight practices and flight restrictions.

Flight

Once pre-flight preparation is complete, it is recommended that you use the flight simulator in the DJI Pilot app to hone your flight skills and practice flying safely. Ensure that all flights are carried out in an open area.

Flight Environment Requirements

1. Do not use the aircraft in severe weather conditions. These include wind speeds exceeding 10 m/s , snow, rain and fog.
2. Only fly in open areas. Tall structures and large metal structures may affect the accuracy of the on-board compass and GPS system.
3. Avoid obstacles, crowds, high voltage power lines, trees, and bodies of water.
4. Minimize interference by avoiding areas with high levels of electromagnetism, including base stations and radio transmission towers.
5. Aircraft and battery performance is subject to environmental factors such as air density and temperature. Be very careful when flying at altitudes greater than 19, 685 feet (6000 meters) above sea level, as the performance of the battery and aircraft may be affected.
6. The Phantom 3 Professional cannot operate within the polar areas.

Flight

Flight Limits and No-Fly Zones

All unmanned aerial vehicle (UAV) operators should abide by all regulations set forth by government and regulatory agencies including the ICAO and the FAA. For safety reasons, flights are limited by default, which helps users operate this product safely and legally. Flight limitations include height limits, distance limits, and No-Fly Zones.

When operating in P-mode, height limits, distance limits, and No-Fly Zones function concurrently to manage flight safety. In A-mode, only height limits are in effect, which by default prevent the aircraft altitude from exceeding 1640 feet (500 m) .

Maximum flight altitude & Radius Limits

Maximum flight altitude and radius limits may be changed in the DJI Pilot app. Be aware that the maximum flight altitude cannot exceed 1640 feet (500 meters). In accordance with these settings, your Phantom 3 Professional will fly in a restricted cylinder, as shown below:

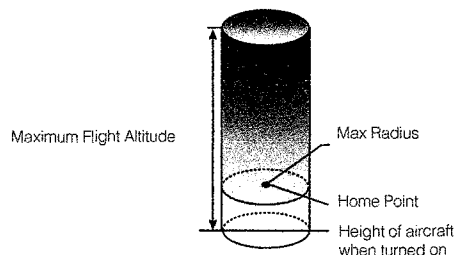

GPS Signal Strong  **Blinking Green**

	Flight Limits	DJI Pilot app	Aircraft Status Indicator
Maximum Flight Altitude	Aircraft's altitude cannot exceed the specified value.	Warning: Height limit reached.	None.
Max Radius	Flight distance must be within the max radius.	Warning: Distance limit reached.	Rapid red flashing  when close to the max radius limit.

GPS Signal Weak  **Blinking Yellow**

	Flight Limits	DJI Pilot app	Aircraft Status Indicator
Maximum Flight Altitude	Height is restricted to 400 feet. (120m) and under.	Warning: Height limit reached.	None.
Max Radius	No limits		



- If you fly out of the limit, you can still control the Phantom 3, but cannot fly it any farther. If the Phantom 3 flies out of the max radius in Ready to Fly (non-GPS) mode, it will fly back within range automatically.
- If the Phantom 3 flies out of the max radius in Ready to Fly (non-GPS) mode, it will fly back within range automatically.

No-Fly Zones

All No-Fly Zones are listed on the DJI official website at <http://flysafe.dji.com/no-fly>. No-Fly Zones are divided into Airports and Restricted Areas. Airports include major airports and flying fields where manned aircraft operate at low altitudes. Restricted Areas include border lines between countries or sensitive institute. The details of the No-Fly Zones are explained as follow:

Airport

- (1) Airport No-Fly Zone are comprised of Take-off Restricted zones and Restricted Altitude Zones. Each zone features circles of various sizes.
- (2) R1 miles (value of the R1 depends on the size and shape of the airport) around the airport is a Take-off restricted zone, inside of which take off is prevented.
- (3) From R1 mile to R1 + 1 mile around the airport the flight altitude is limited to a 15 degree inclination. Starting at 65 feet (20 meters) from the edge of airport and radiating outward. The flight altitude is limited to 1640 feet (500 meters) at R1+1 mile
- (4) When the aircraft enters within 320 feet (100 meters) of No-Fly Zones, a warning message will appear on the DJI Pilot app.

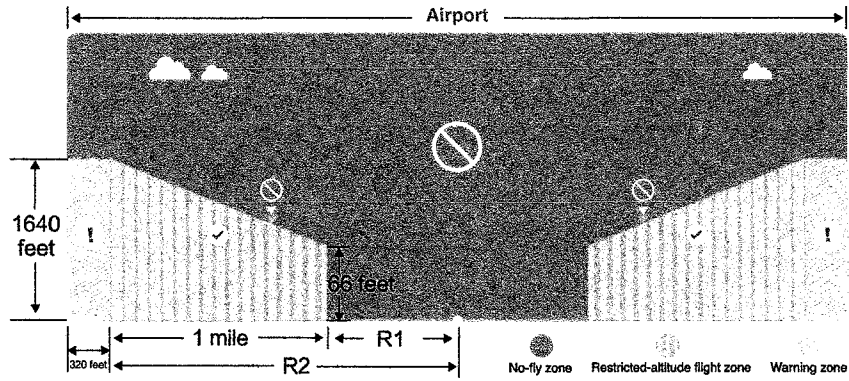







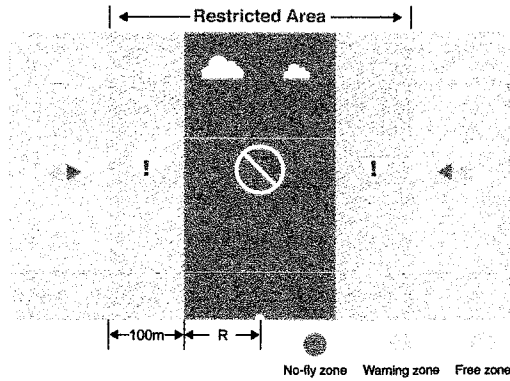

Flight

Restricted Area

- (1) Restricted Areas does not have flight altitude restrictions.
- (2) R miles around the designated restriction area is a Take-off Restricted area. Aircraft cannot take off within this zone. The value of R varies based on the definition of the restricted areas.
- (3) A "warning zone" has been set around the Restricted Area. When the aircraft approaches within 0.6 miles (1 km) of this zone, a warning message will appear on the DJI Pilot app.



GPS Signal Strong  Blinking Green			
Zone	Restriction	DJI Pilot App Prompt	Aircraft Status Indicator
No-fly Zone 	Motors will not start.	Warning: You are in a No-fly zone. Take off prohibited.	 Red flashing  Flight
	If the aircraft enters the restricted area in A-mode, but is switched to P-mode, the aircraft will automatically descend, land, and stop its motors.	Warning: You are in a no-fly zone. Automatic landing has begun.	
Restricted-altitude flight zone 	If the aircraft enters the restricted area in A-mode, but is switched to P-mode, it will descend to an appropriate altitude and hover 15 feet below the altitude limit.	R1: Warning: You are in a restricted zone. Descending to safe altitude. R2: Warning: You are in a restricted zone. Maximum flight altitude is restricted to between 20m and 500m. Fly cautiously.	
Warning zone 	No flight restriction applies, but there will be a warning .	Warning: You are approaching a restricted zone, Fly cautiously.	
Free zone 	No restrictions.	None.	None.

 Semi-automatic descent: All stick commands are available except the throttle stick command during the descent and landing process. Motors will stop automatically after landing.

-  When flying in a safety zone, the aircraft's status indicator will blink red rapidly and continue for 3 seconds, then switch to indicate current flying status and continue for 5 seconds at which point it will switch back to blinking red.
- For safety reasons, please do not fly close to airports, highways, railway stations, railway lines, city centers, or other sensitive areas. Fly the aircraft only within your line of sight.

Preflight Checklist

1. Remote controller, Intelligent Flight Battery, and mobile device are fully charged.
2. Propellers are mounted correctly and firmly.
3. Micro-SD card has been inserted, if necessary.
4. Gimbal is functioning normally.
5. Motors can start and are functioning normally.
6. The DJI Pilot app is successfully connected to the aircraft.

Calibrating the Compass

IMPORTANT: Always calibrate the compass in every new flight location. The compass is very sensitive to electromagnetic interference, which can produce abnormal compass data and lead to poor flight performance or flight failure. Regular calibration is required for optimal performance.

- Do not calibrate your compass where there is any possibility of strong magnetic interference. Sources of potential interference include magnetite, parking structures, and subterranean metal structures
- Do not carry ferromagnetic materials with you during calibration such as keys or cellular phones.
- Do not calibrate in direct proximity to large metal objects.
- DO NOT calibrate indoors.

Flight

Calibration Procedures

Choose an open area to carry out the following procedures.

1. Ensure that the compass is calibrated. If you did not calibrate the compass as part of your pre-flight preparations, or if you have moved to a new location since the last calibration, tap the Aircraft Status Bar in the app and select "Calibrate", then follow the on-screen instructions.
2. Hold the aircraft horizontally and rotate 360 degrees. The Aircraft Status Indicators will display a solid green light.

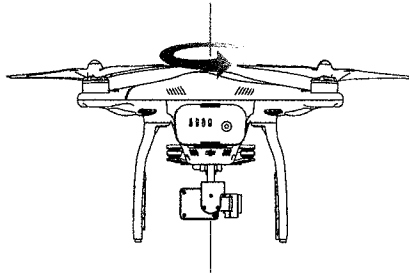

3. Hold the aircraft vertically, with nose pointing downward, and rotate it 360 degrees around the center axis. Recalibrate the compass if the Aircraft Status Indicator glows solid red.

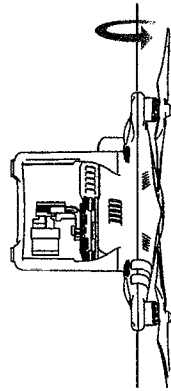

Flight

⚠ If the Aircraft Status Indicator blinks red and yellow after the calibration procedure, move your aircraft to a different location and try again.

☀ Calibrate the compass before each flight. Launch the DJI Pilot app and follow the on-screen instructions to calibrate the compass. DO NOT calibrate the compass near metal objects such as a metal bridge, cars, scaffolding.

When to Recalibrate

1. When compass data is abnormal and the Aircraft Status Indicator is blinking green and yellow.
2. When flying in a new location or in a location that is different from the most recent flight.
3. When the mechanical or physical structure of the Phantom 3 Professional has been changed.
4. When severe drifting occurs in flight, i.e. Phantom 3 Professional does not fly in straight line.

Auto Takeoff and Auto Landing

Auto Takeoff

Use auto takeoff only if the Aircraft Status Indicators are blinking green. Follow the steps below to use the auto takeoff feature:

1. Launch the DJI Pilot app, and enter "Camera" page.
2. Ensure the aircraft is in P- mode.
3. Complete all steps on the pre-flight checklist.
4. Tap "🚀", and confirm that conditions are safe for flight. Slide the icon to confirm and takeoff.
5. Aircraft takes off and hovers at (1.5 meters) above ground.

⚠ Aircraft Status Indicator blinks rapidly when it is using the Vision Position System for stabilization. The aircraft will automatically hover below 3 meters. It is recommended to wait until there is sufficient GPS lock before using the Auto Take-off feature.

Auto-Landing

Use auto-landing only if the Aircraft Status Indicators are blinking green. Follow the steps below to use the auto-landing feature:

1. Ensure the aircraft is in P- mode.
2. Check the landing area condition before tapping "↓", to begin landing. Then follow the on-screen instructions.

Starting/Stopping the Motors

Starting the Motors

A Combination Stick Command (CSC) is used to start the motors. Push both sticks to the bottom inner or outer corners to start the motors. Once the motors have started spinning, release both sticks simultaneously.

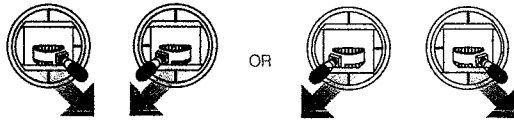

Stopping the Motors

There are two methods to stop the motors.

Method 1: When Phantom 3 Professional has landed, push the throttle down, then conduct the same CSC that was used to start the motors, as described above. Motors will stop immediately. Release both sticks once motors stop.

Method 2: When the aircraft has landed, push and hold the throttle down. The motors will stop after three seconds.

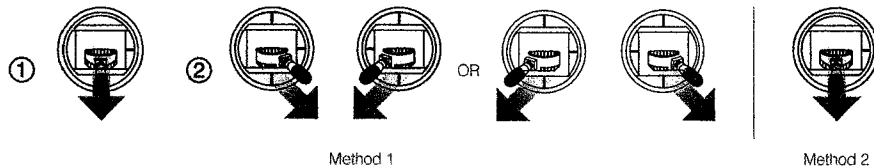

⚠ Do not perform a CSC when the aircraft is in midair, otherwise the motors will suddenly stop.

Flight Test

Takeoff/Landing Procedures

1. Place the aircraft in an open, flat area with the battery level indicators facing towards you.
2. Turn on the remote controller and your mobile device, then turn on the Intelligent Flight Battery.
3. Launch the DJI Pilot app and enter the Camera page.
4. Wait until the Aircraft Indicators blink green. This means the Home Point is recorded and it is now safe to fly. If they flash yellow, the Home Point has not been recorded.
5. Push the throttle up slowly to take off or use Auto Takeoff.
6. Shoot photos and videos using the DJI Pilot app.
7. To land, hover over a level surface and gently pull down on the throttle to descend.
8. After landing, execute the CSC command or hold the throttle at its lowest position until the motors stop.
9. Turn off the Intelligent Flight Battery first, then the Remote Controller.

-  • When the Aircraft Status Indicators blink yellow rapidly during flight, the aircraft has entered Failsafe mode.
- A low battery level warning is indicated by the Aircraft Status Indicators blinking red slowly or rapidly during flight.
 - Watch our video tutorials for more flight information.
-

Video Suggestions and Tips

1. Go through the full pre-flight checklist before each flight.
2. Select the desired gimbal operation mode in the DJI Pilot app.
3. Only shoot video when flying in P-mode.
4. Always fly in good weather and avoid flying in rain or heavy wind.
5. Choose the camera settings that suit your needs. Settings include photo format and exposure compensation.
6. Perform flight tests to establish flight routes and preview scenes.
7. Push the control sticks gently to keep the aircraft's movement smooth and stable.



FAQ

Troubleshooting (FAQ)

What is the difference between the Phantom 3 Professional and the Phantom 3 Advanced?

The biggest difference between the Phantom 3 Professional and the Phantom 3 Advanced is in the camera. The Phantom 3 Professional is capable of shooting spectacular 4K video at up to 30 frames per second, and the Phantom 3 Advanced is capable of shooting at resolutions up to 1080p60. Both models shoot 12 megapixel photos.

The other main difference is the Intelligent Flight Battery charger. The Phantom 3 Advanced comes with a 57-watt charging unit and the Phantom 3 Professional comes with a 100-watt charger, the latter of which allows for shorter charging times.

Can I remove the camera and attach my own?

No. The cameras that come with both models are permanently attached. Attempting to remove, replace, or modify the camera may damage the product and will void your warranty.

Can I charge my Remote Controller and Intelligent Flight Battery at the same time?

While the Remote Controller charger and Intelligent Flight Battery charger have been integrated into one unit for your convenience, it is recommended that you only charge one item at a time. We recommend that you never charge both items using the same charger at the same time.

What are the buttons on the back of my Remote Controller for?

The two buttons on the back of the Remote Controller can be customized and assigned to function as you choose through the DJI Pilot app. Refer to the manual for more information.

How far can I fly my Phantom 3?

The signal transmission distance will vary depending on environmental conditions, but the Phantom 3 series can reach distances of up to 1.2 miles (2 kilometers) away from the pilot.

What app should I use with my Phantom 3?

The Phantom 3 is compatible with the DJI Pilot app for iOS and Android, which is already used with the DJI Inspire. The app will detect which aircraft is connected and automatically adjust accordingly.

Which mobile devices are compatible with the app?

The DJI Pilot app is only compatible with devices running iOS 8.0 or later or Android v4.1.2 or later.

The following devices are recommended:

iOS: iPhone 5s, iPhone 6, iPhone 6 Plus, iPad Air, iPad Air Wi-Fi + Cellular, iPad mini 2, iPad mini 2 Wi-Fi + Cellular, iPad Air 2, iPad Air 2 Wi-Fi + Cellular, iPad mini 3, and iPad mini 3 Wi-Fi + Cellular. This app is optimized for iPhone 5s, iPhone 6, and iPhone 6 Plus

Android: Samsung S5, Note 3, Sony Z3 EXPERIA, Google Nexus 7 II, Google Nexus 9, Mi 3, Nubia Z7 mini
Support for additional Android devices will become available as testing and development continues.

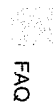

FAQ

How do I use the Director automatic video editor?

Director is an automatic video editor built into the DJI Pilot app. After recording several video clips, simply tap "Director" from the app's home screen. You can then select a template and a specified number of clips, which are automatically combined to create a short film that can be shared immediately.

How do I change the control mode of my Phantom 3?

By default, the Remote Controller is set to Mode 2. This means that the right control stick controls the movement of the aircraft and the left control stick controls the throttle and orientation of the aircraft. These controls can be changed to Mode 1 or set to a customized configuration in the DJI Pilot app. This is only recommended for advanced users.

Can I use a Phantom 2 Remote Controller with the Phantom 3?

No. The Phantom 2 Remote Controller operates on a different frequency. The Phantom 2 Remote Controller operates at 5.8 GHz and the new Phantom 3 Remote Controller operates at 2.4 GHz.

Can I use a Phantom 2 Intelligent Flight Battery with the Phantom 3?

No. The Phantom 3 uses a newly designed Intelligent Flight Battery with greater power. The Phantom 3 has a 4 cell battery with a capacity of 4480 mAh and a voltage of 15.2 V.

My Phantom 3 does not turn off right away, is something wrong?

This is normal. After you attempt to power off the Intelligent Flight Battery, it may remain on for a few seconds as any video data is saved to the Micro SD card. This helps prevent your data from being lost or corrupted.

Do I have to buy the Remote Controller separately?

No, there is no need to buy a separate Remote Controller. Your Phantom 3 comes with a Remote Controller that is already linked to the aircraft.

Does my Phantom 3 support dual Remote Controllers?

No. The included Remote Controller can be used to control both the aircraft and the gimbal tilt at the same time.

What does the "P, A, F" switch on the Remote Controller do?

This switch, called the Flight Mode Switch, allows you to toggle different flight modes:

P-mode, or Positioning mode, indicates that both GPS and the Vision Positioning System are active and your Phantom 3 will attempt to stabilize using both.

In A-mode, or Attitude mode, the aircraft does not use GPS or the Vision Positioning System. Only the barometer is used for stabilization. The aircraft can still return to the Home Point as long as a sufficient GPS signal is available.

F-mode, or Function mode, activates Intelligent Orientation Control (IOC) functionality. Refer to the IOC section in the Appendix of the User Manual.

By default, only P-mode may be used. Refer to your user manual for instructions on unlocking the other modes.

What is the Phantom 3 flight time?

Flight times will vary depending on environmental conditions and usage patterns, but the Intelligent Flight Battery is designed to provide up to 23 minutes of uninterrupted flight time when fully charged.

How can I restore a video file if the power is turned off during recording?

Do not remove the Micro-SD card from the camera. If it has been removed, place it back in the camera. Turn the Phantom 3 on and wait approximately 30 seconds as the video file is restored.

How can I ensure that my pictures and videos will be synchronized to my iOS album?

You may need to adjust the settings of your mobile device. Open the Settings menu, select the Privacy tab, select the Photos tab, and then toggle the switch next to the DJI Pilot app icon. If the Pilot app has not been granted access to your albums, the photos and videos cannot be synchronized.

What should I do to land my Phantom 3 smoothly as possible?

Hover the aircraft over a flat, level surface. Slowly pull the throttle stick down until the aircraft touches the ground.

Why is the discharge time of the battery not zero, even though I have never used it?

Every battery is tested prior to being packaged and shipped. This affects the discharge time of a new battery and is the reason that the discharge time is not zero. The battery is safe to use.

Can the mobile device holder be used on the Phantom 2 series Remote Controller?

No, it cannot.

How to safely operate the aircraft when encountering compass error?

A compass error may occur when the aircraft is flying close to strong electric magnetic sources (e.g. power transmission lines). Aircraft Status Indicators blink red and yellow rapidly when a compass error occurs and the DJI Pilot app will display one of the following messages:

- Compass error, calibration required

This warning message indicates the aircraft is receiving abnormal compass readings. It is recommended to power off the aircraft and re-calibrate the compass at a different location and then resume the flight.

- Compass error, exit P-GPS Mode

This warning message indicates that the aircraft is drifting severely. Bring the aircraft to a higher altitude to gain enough GPS satellite locks when this warning message is prompted. The flight controller will automatically adjust the orientation of the aircraft in the midair to mitigate the drifts. The aircraft will switch back to P-GPS mode when the automatic adjustment is completed.

Appendix

Appendix

Specifications

Aircraft

Weight (Battery & Propellers Included)	1280 g
Max. Ascent Speed	5 m/s
Max. Descent Speed	3 m/s
Max. Speed	16 m/s (ATTI mode, no wind)
Max. Flight Altitude	6000 m
Max. Flight Time	Approximately 23 minutes
Operating Temperature	0°C to 40°C
GPS Mode	GPS/GLONASS

Gimbal

Controllable Range	Pitch: - 90° to + 30°
--------------------	-----------------------

Vision Positioning

Velocity Range	< 8 m/s (2 m above ground)
Altitude Range	30 cm-300 cm
Operating Range	30 cm-300 cm
Operating Environment	Brightly lit (lux > 15) patterned surfaces

Camera

Sensor	Sony EXMOR 1/2.3" Effective pixels:12.4 M (total pixels: 12.76 M)
Lens	FOV 94° 20mm(35mm format equivalent) f/2.8
ISO Range	100-3200(video) 100-1600(photo)
Electronic Shutter Speed	8s -1/8000s
Image Max. Size	4000 x 3000
	Single shot
	Burst shooting: 3/5/7 frames
Still Photography Modes	Auto Exposure Bracketing (AEB): 3/5 Bracketed frames at 0.7EV Bias Time-lapse
Supported SD Card Types	Micro SD Max. capacity: 64 GB. Class 10 or UHS-1 rating required
Video Recording Modes	UHD : 4096x2160p 24/25, 3840x2160p24/25/30 FHD:1920x1080p 24/25/30/48/50/60 HD:1280x720p 24/25/30/48/50/60
Max. Bitrate Of Video	60 Mbps
Storage	FAT32/exFAT
Supported File Formats	Photo: JPEG, DNG Video: MP4/MOV (MPEG-4 AVC/H.264)
Operating Temperature Range	0°C to 40°C

Remote Controller

Operating Frequency	2.400 GHz-2.483 GHz
Transmitting Distance	2000 m (Outdoor And Unobstructed)
Video Output Port	USB
Operating Temperature Range	0°C- 40°C
Battery	6000 mAh LiPo 2S
Mobile Device Holder	Tablets and smartphones
Transmitter Power(EIRP)	FCC: 20 dbm; CE:16 dbm
Working Voltage	1.2 A @7.4 V

Charger

Voltage	17.4 V
Rated Power	100 W

Intelligent Flight Battery (PH3-4480 mAh-15.2 V)

Capacity	4480 mAh
Voltage	15.2 V
Battery Type	LiPo 4S
Energy	68 Wh
Net Weight	365 g
Operating Temperature	-10°C- 40°C
Max. Charging Power	100 W

Aircraft Status Indicator Description

Normal

R (G Y) Red, Green and Yellow Flash Alternately	Turning on and Self-Diagnostics
G Y Green and Yellow Flash Alternately	Aircraft Warming Up
G Green Flashes Slowly	Safe to Fly (P-mode with GPS and Vision Positioning)
G X2 Green Flashes Twice	Safe to Fly (P-mode with Vision Positioning but without GPS)
Y Yellow Flashes Slowly	Safe to Fly (A-mode but No GPS and Vision Positioning)

Warning

Y Fast Yellow Flashing	Remote Controller Signal Lost
R Slow Red Flashing	Low Battery Warning
R Fast Red Flashing	Critical Battery Warning
R Red Flashing Alternately	IMU Error
R — Solid Red	Critical Error
R Y Red and Yellow Flash Alternately	Compass Calibration Required

Intelligent Orientation Control (IOC)



IOC allows users to lock the control orientation of the aircraft in different modes. There are three working modes for IOC that can be selected in the DJI Pilot app. IOC only works when the aircraft is in F-mode, therefore the user must toggle the flight mode switch to activate IOC. Refer to the table below:

Course Lock (CL)	The nose direction, at the time that CL is set, will remain the forward direction regardless of how the orientation and position of the aircraft changes. This will remain fixed until you reset it or exit CL mode.
Home Lock (HL)*	Record a Home Point (HP) and enter HL mode. The forward and backward controls will move the aircraft farther from and closer to the established Home Point, regardless of how the orientation and position of the aircraft changes.
Point of Interest (POI)*	Point of Interest. Record a point of interest (POI). The aircraft can then circle around the POI and the nose will always point toward the POI.

 *Home Lock and Point of Interest feature are coming soon.

IOC Requirements

IOC is only available under the following conditions:

Modes IOC	GPS enabled	GPS counts	Flight Distance Limits
Course Lock	No	None	None
Home Lock	Yes		Aircraft $\leftarrow \geq 10m \rightarrow$ Home Point
POI	Yes		Aircraft $\leftarrow 5m-500m \rightarrow$ Point of Interest

Using IOC

Toggle the Flight Mode Switch F-mode and follow the instructions prompted on the DJI Pilot app to select the desired IOC mode.

FCC Compliance

FCC Compliance

This device complies with part 15 of the FCC Rules. Operation is subject to the following two conditions:

- (1) This device may not cause harmful interference, and
- (2) This device must accept any interference received, including interference that may cause undesired operation.

Changes or modifications not expressly approved by the party responsible for compliance could void the user's authority to operate the equipment.

Compliance Information

FCC Warning Message

Any changes or modifications not expressly approved by the party responsible for compliance could void the user's authority to operate the equipment.

This device complies with part 15 of the FCC Rules. Operation is subject to the following two conditions:

- (1) This device may not cause harmful interference, and
- (2) this device must accept any interference received, including interference that may cause undesired operation.

FCC Radiation Exposure Statement:

This equipment complies with FCC radiation exposure limits set forth for an uncontrolled environment. This equipment should be installed and operated with minimum distance 20cm between the radiator & your body. This transmitter must not be co-located or operating in conjunction with any other antenna or transmitter.

Note: This equipment has been tested and found to comply with the limits for a Class B digital device, pursuant to part 15 of the FCC Rules. These limits are designed to provide reasonable protection against harmful interference in a residential installation. This equipment generates uses and can radiate radio frequency energy and, if not installed and used in accordance with the instructions, may cause harmful interference to radio communications. However, there is no guarantee that interference will not occur in a particular installation. If this equipment does cause harmful interference to radio or television reception, which can be determined by turning the equipment off and on, the user is encouraged to try to correct the interference by one or more of the following measures:

- Reorient or relocate the receiving antenna.
- Increase the separation between the equipment and receiver.
- Connect the equipment into an outlet on a circuit different from that to which the receiver is connected.
- Consult the dealer or an experienced radio/TV technician for help.

IC RSS warning

This device complies with Industry Canada licence-exempt RSS standard (s). Operation is subject to the following two conditions: (1) this device may not cause interference, and (2) this device must accept any interference, including interference that may cause undesired operation of the device.

Le présent areil est conforme aux CNR d'Industrie Canada licables aux areils radio exempts de licence.

L'exploitation est autorisée aux deux conditions suivantes:

- (1) l'areil ne doit pas produire de brouillage, et
- (2) l'utilisateur de l'areil doit accepter tout brouillage radioélectrique subi, même si le brouillage est

susceptible d'en compromettre le fonctionnement.

IC Radiation Exposure Statement:

This equipment complies with IC RF radiation exposure limits set forth for an uncontrolled environment. This transmitter must not be co-located or operating in conjunction with any other antenna or transmitter. This equipment should be installed and operated with minimum distance 20cm between the radiator& your body.

Any Changes or modifications not expressly approved by the party responsible for compliance could void the user's authority to operate the equipment.

KCC Warning Message

"해당 무선설비는 운용 중 전파혼신 가능성이 있으므로 인명안전과 관련된 서비스는 할 수 없습니다."

"해당 무선설비는 운용 중 전파혼신 가능성이 있음"

NCC Warning Message

低功率電波輻射性電機管理辦法

第十二條經型式認證合格之低功率射頻電機，非經許可，公司、商號或使用者均不得擅自變更頻率、加大功率或變更原設計之特性及功能。

第十四條低功率射頻電機之使用不得影響飛航安全及干擾合法通信；經發現有干擾現象時，應改善至無干擾時方得繼續使用。前項合法通信，指依電信法規定作業之無線電通信。低功率射頻電機須忍受合法通信或工業、科學及醫療用電波輻射性電機設備之干擾。

The content is subject to change.

Download the latest version from
<http://www.dji.com/product/phantom-3>



If you have any questions about this document, please contact DJI by sending a message to DocSupport@dji.com.

© 2015 DJI. All Rights Reserved.

2015.5.8

Overview :

1. All-in-One Firmware version updated to : v1.1.8

Major Updates :

1. Fixed the issue of failure to update the firmware if the remote controller is turned off.

Notice :

- Users are advised to update the firmware version to v1.1.8, otherwise future firmware will not be able to install.
- Re-link the remote controller to the aircraft if the connection is lost after the firmware update.

2015.5.6

Overview :

2. All-in-One Firmware version updated to : v1.1.6
3. DJI Pilot app iOS version updated to: v1.1.1
4. DJI Pilot app Android version updated to: v1.1.0

Major Updates :

Updated to be compatible with the iOS version of the DJI Pilot app.

Notice :

Re-link the remote controller to the aircraft if the connection is lost after the firmware upgrade.

PHANTOM 3

PROFESSIONAL

Quick Start Guide

V1.0

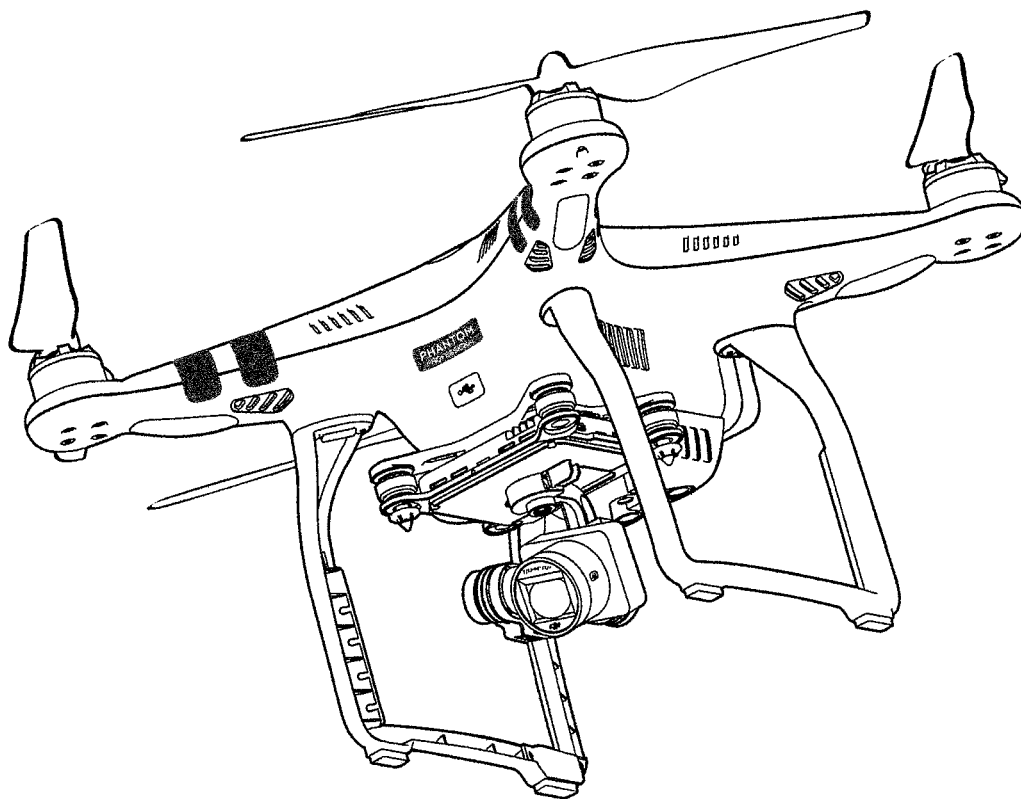

Phantom 3 Professional

It's time to meet your Phantom 3 Professional.

The Phantom 3 Professional's camera records video at up to 4K and captures 12 megapixel photos.

Review the diagram below for a full list of your Phantom 3 Professional's parts:

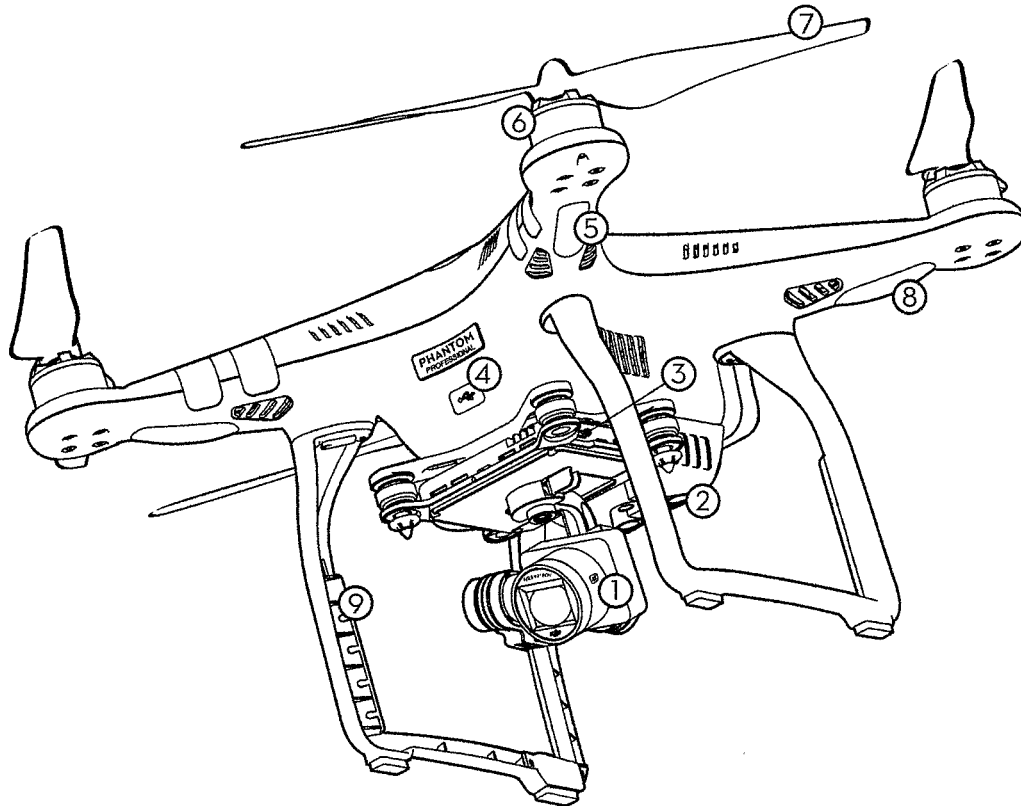

- | | |
|------------------------------|--------------------------------|
| 1. Gimbal and Camera | 8. Aircraft Status Indicators |
| 2. Vision Positioning System | 9. Antennas |
| 3. Camera Micro-SD Card Slot | 10. Intelligent Flight Battery |
| 4. Aircraft Micro-USB Port | 11. Power Button |
| 5. Front LEDs | 12. Battery Level Indicators |
| 6. Motors | 13. Link Button |
| 7. Propellers | 14. Camera Micro-USB Port |

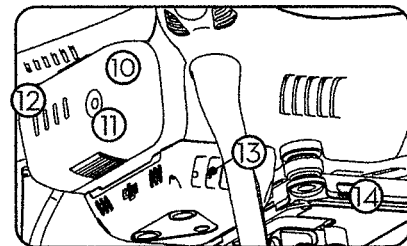

Remote Controller

This powerful Remote Controller allows you to pilot and maneuver your Phantom 3 Professional at distances over 6,000 feet (2 km)* away, while putting selected camera controls at your fingertips.

Built into your Remote Controller is a rechargeable LiPo battery and DJI Lightbridge, which when paired with a compatible mobile device gives you a live HD view from the Phantom's camera.

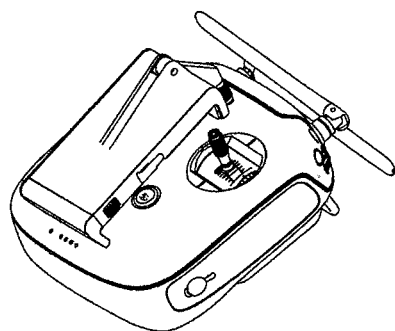

Folded

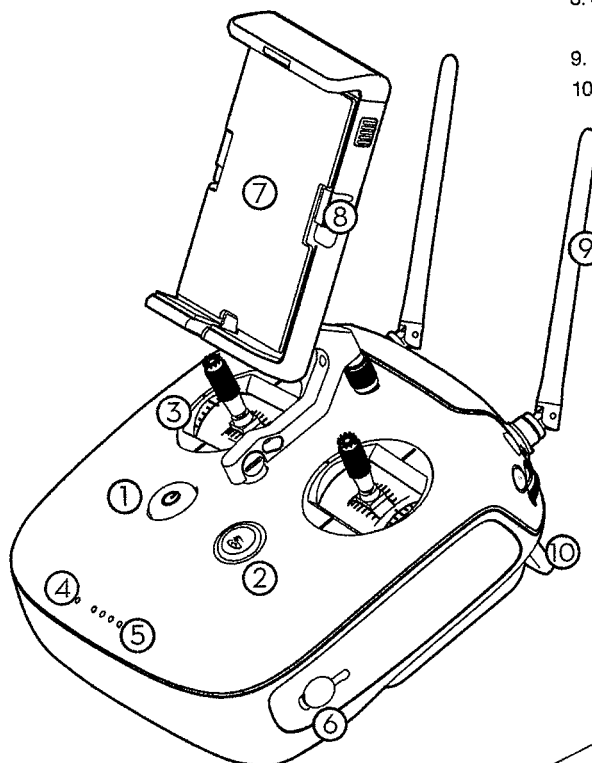

1. Power Button
2. Return to Home (RTH) Button
3. Control Sticks
4. Status LED
5. Battery Level LEDs
6. Power Port
7. Mobile Device Holder
8. Small Device Positioning Tabs (such as mobile phone)
9. Antennas
10. Handle Bar

11. Gimbal Dial
12. Camera Settings Dial
13. Video Recording Button
14. Flight Mode Switch
15. Shutter Button
16. Playback Button
17. C1/C2 Buttons (Customizable)
18. USB Port
19. Micro-USB Port

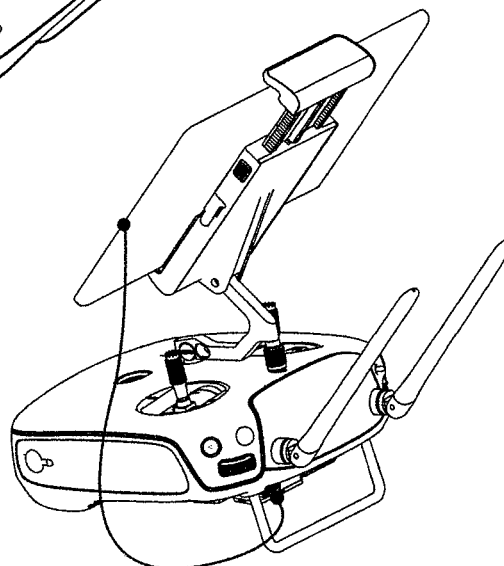
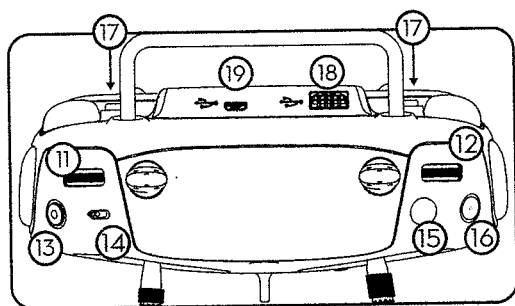

Mobile device connection

* This maximum transmission distance was tested in a lab environment and is for reference only. The maximum operating distance may vary depending on conditions in your immediate surroundings.

Fly Safe

DJI encourages you to enjoy flying your Phantom 3 Professional in a safe, responsible, and smart way. To do this, it is important to understand some basic flight guidelines, both for your protection and for the safety of those around you.

1. **Fly in Open Areas:** Always fly in locations that are free and clear of buildings, trees, power lines, and other obstacles. Do not fly above or near people or animals.
2. **Maintain Control at All Times:** Even when using DJI autopilot functions such as Auto-Takeoff, Auto-Landing, and Auto-Return to Home, always keep your hands on the Remote Controller and maintain control of your aircraft when it is in flight.
3. **Maintain Line of Sight:** Keep your aircraft in sight at all times, and avoid flying behind buildings or other obstacles that may block your view.
4. **Monitor Your Altitude:** For the safety of full-sized aircraft and other air traffic, always fly at altitudes less than 400 feet (120 meters) above ground level, or in line with your local laws and regulations.

Visit <http://fllysafe.dji.com/no-fly> for more information on critical safety features such as No-Fly Zones.



● Calibrating the Compass:

Make sure to calibrate the compass at every new flight location. The compass is very sensitive to electromagnetic interference, which can cause abnormal compass data, leading to poor flight performance or even failure. Regular calibration is required for optimal performance.

1. DO NOT calibrate your compass where there is a chance of strong magnetic interference, such as magnetite, parking structures, and steel reinforcements underground.
2. DO NOT carry ferromagnetic materials with you during calibration such as keys or cellular phones.
3. DO NOT calibrate beside massive metal objects.
4. If the Aircraft Status Indicators are showing solid red, then try to calibrate again. If they are blinking red and yellow alternately after placing the aircraft on the ground, the compass has detected magnetic interference. Change your location.

● Environmental Considerations:

1. Do not fly in severe weather conditions. This includes high winds (speeds of 22 mph or 10 m/s or more), snow, rain, and fog.
2. Only fly in open areas. Tall buildings and steel structures may affect the accuracy of the on-board compass and GPS signal.
3. Avoid obstacles, crowds, high-voltage power lines, trees, and bodies of water.
4. Minimize electromagnetic interference by avoiding areas with high levels of electromagnetism, including mobile phone base stations, radio transmission towers, or Wi-Fi hotspots.
5. Aircraft and battery performance are subject to environmental factors such as air density and temperature. Be very careful when flying 19,600 feet (6 km) or more above sea level, as battery and aircraft performance may not be at peak efficiency.
6. The Phantom 3 Professional cannot operate in P Mode or use GPS at polar latitudes. Only ATTI Mode and the Vision Positioning system will be operational.

● P Mode:

In this mode, the Phantom 3 Professional can use GPS and the Vision Positioning system, allowing it to hover accurately in position indoors and out. When GPS is available, a Home Point will be locked so that the Phantom 3 Professional can Return to Home if the Remote Controller signal is lost.

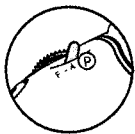

To enable P Mode, toggle the Flight Mode Switch to the P position.

There are three states in P mode:

P-GPS: GPS works best when outdoors and in a wide open area. Your Phantom 3 Professional uses GPS to hover in place when there is a strong GPS signal.

P-OPTI: If GPS is not available, the aircraft can use the Vision Positioning system to hover accurately.

P-ATTI: Neither GPS nor the Vision Positioning system are available. The aircraft will only use its barometer for altitude and other on-board sensors for attitude stabilization.

Note that the Vision Positioning system may not work properly when the Phantom 3 Professional is flying over water, over surfaces without a clear pattern, or in a low-light environment.

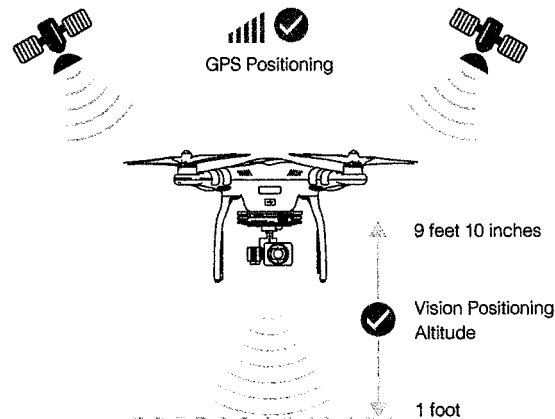

● Return to Home:

When there is a strong GPS signal, the aircraft will be able to record a Home Point and return to that Home Point when required. The Home Point location is recorded when the GPS signal icon in the DJI Pilot app is either yellow or green.

The aircraft will return to the Home Point automatically in the following scenarios (all require a strong GPS signal):

Smart RTH: When the RTH button on the Remote Controller or in the DJI Pilot app is pressed.

Low-Battery RTH: A notification will appear in the DJI Pilot app requesting the pilot to take action when the battery level falls under a certain level.

Failsafe RTH: When the Remote Controller's signal is lost.



- While returning to the Home Point, the aircraft's altitude can be adjusted to avoid obstacles. Tall buildings may affect the Remote Controller's signal. The Failsafe Return to Home procedure will be triggered if the signal is lost. Be sure to fly higher than any nearby buildings to avoid crashing.

Appendix

• Aircraft

Weight (Including Battery)	1280 g
Max. Ascent Speed	5 m/s
Max. Descent Speed	3 m/s
Max. Speed	16 m/s (ATTI mode, no wind)
Max. Flight Altitude	6000 m
Max. Flight Time	Approximately 23 minutes
Operating Temperature Range	0°C to 40°C
GPS	GPS/GLONASS

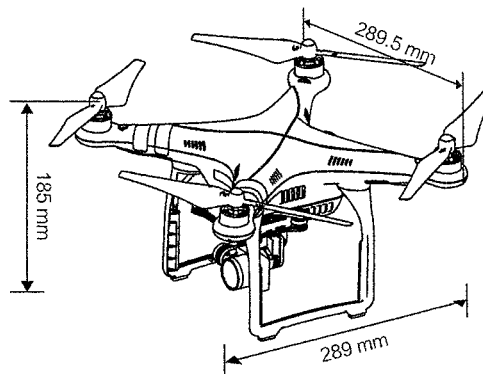

• Gimbal

Angular Vibration Range	Pitch: - 90° to +30°
-------------------------	----------------------

• Vision Positioning

Velocity Range	<8 m/s (Altitude 2 m)
Altitude Range	30 cm-300 cm
Operating Range	30 cm-300 cm
Operating Environment	Surface with clear pattern and adequate lighting (Lux > 15)

• Camera

Sensor	Sony EXMOR 1/2.3" Effective pixels:12.4 M (total pixels: 12.76 M)
Lens	FOV (Field Of View) 94° 20 mm (35 mm format equivalent) f/2.8
ISO Range	100-3200 (video) 100-1600 (photo)
Electronic Shutter Speed	8 s - 1/8000 s
Image Max. Size	4000 x 3000
Still Photography Modes	Single shot Burst shooting: 3/5/7 frames Auto Exposure Bracketing (AEB): 3/5 bracketed frames at 0.7EV Bias Time-lapse
Video Recording Modes	UHD : 4096x2160p 24/25, 3840x2160p 24/25/30 FHD: 1920x1080p 24/25/30/48/50/60 HD: 1280x720p 24/25/30/48/50/60
Max. Bitrate of Video Storage	60 Mbps
Supported File Formats	FAT32/exFAT Photo: JPEG, DNG Video: MP4/MOV (MPEG-4 AVC/H.264)
Supported SD Card Types	Micro-SD, Max. capacity: 64GB. Class 10 or UHS-1 rating required
Operating Temperature Range	0°C to 40°C

• Remote Controller

Operating Frequency	2.400 GHz-2.483 GHz
Max. Transmission Distance	2 km (outdoors and unobstructed)
Video Output Port	USB
Operating Temperature Range	0°C to 40°C
Battery	6000 mAh LiPo 2S
Mobile Device Holder	Tablets and smartphones
Transmitter Power (EIRP)	FCC: 20 dbm; CE:16 dbm
Working Voltage	1.2 A @7.4 V

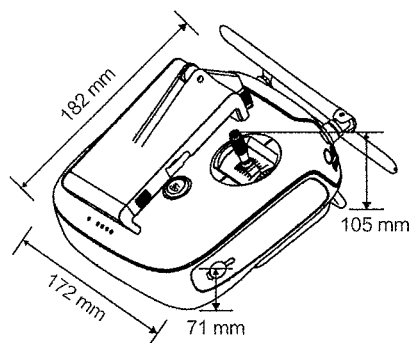

• Charger

Voltage	17.4 V
Rated Power	100 W

• Intelligent Flight Battery (PH3-4480 mAh-15.2 V)

Capacity	4480 mAh
Voltage	15.2 V
Battery Type	LiPo 4S
Energy	68 Wh
Net Weight	365 g
Operating Temperature	-10°C to 40°C
Max. Charging Power	100 W

CE 1313 RoHS

FCC ID: S53-WM3231503 FCC ID: S53-GL3001501

This device complies with part 15 of the FCC Rules.

Operation is subject to the following two conditions:

- (1) This device may not cause harmful interference, and
- (2) this device must accept any interference received, including interference that may cause undesired operation.

PHANTOM 3

PROFESSIONAL

Preparing Your Phantom 3 Professional Before Flying

Read the User Manual and watch the video tutorials in the DJI Pilot app or on the official DJI website (www.dji.com), and read the following documents included in the box before using your Phantom 3 Professional for the first time: *Phantom 3 Professional Quick Start Guide*, *Phantom 3 Professional / Advanced Safety Guidelines and Disclaimer*, *Phantom 3 Professional / Advanced Intelligent Flight Battery Safety Guidelines*, *In the Box*.

1. Download the DJI Pilot App

Search 'DJI Pilot' on the App Store or Google Play and download the DJI Pilot app to your mobile device.



DJI Pilot app

2. Watch the Tutorial Videos

Watch the tutorial videos on www.dji.com or in the DJI Pilot app.



Phantom 3 tutorial videos



• For the best experience, use a mobile device that runs iOS 8.0 or above or Android 4.1.2 or above.

3. Check Battery Levels

Pressing the Power Button once on either your Intelligent Flight Battery or Remote Controller displays the battery level.

Be sure to fully charge both batteries before your first flight.

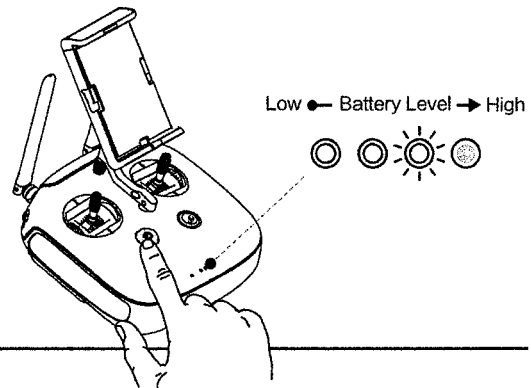
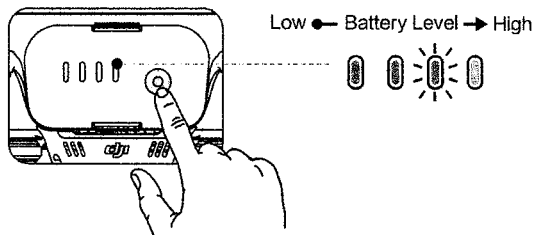

4. Charging the Batteries

- Only use the official DJI Phantom 3 Professional charger. Remove the Intelligent Flight Battery from the aircraft before charging.
- It is recommended that you turn off the Intelligent Flight Battery or Remote Controller before charging.
- Connect the charger to a suitable power source (100-240V 50/60Hz).
- Connect the charger to the Intelligent Flight Battery or Remote Controller. The LEDs will display the current charge level, and when fully charged, they will automatically turn off.

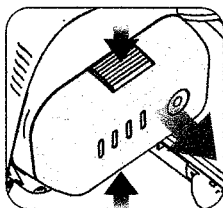

Remove the Intelligent Flight Battery

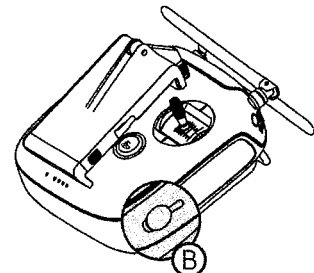
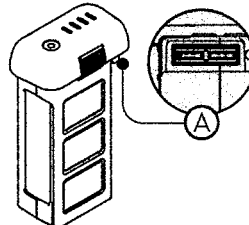
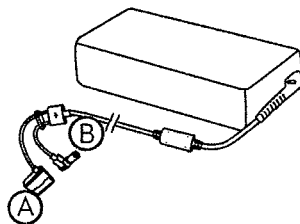

5. Preparing the Remote Controller

Tilt the Mobile Device Holder to the desired position, and then adjust the antennas as shown. The strength of the Remote Controller's signal will fluctuate depending on the positions of the antennas.

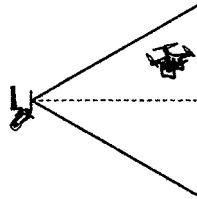
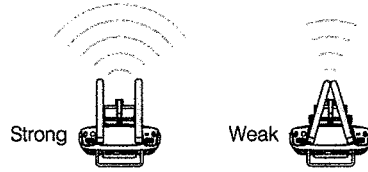

The transmission signal between the aircraft and Remote Controller will be strongest within the range illustrated here. If the signal is weak, adjust the positions of the antennas and fly the aircraft closer to achieve optimal signal performance.

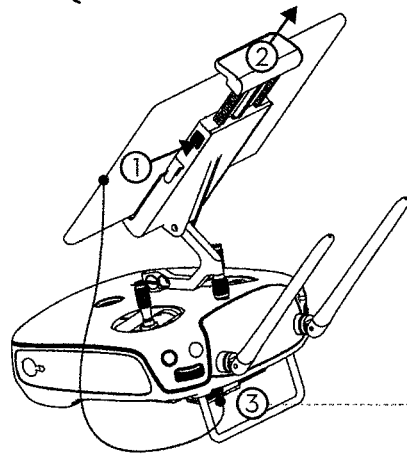
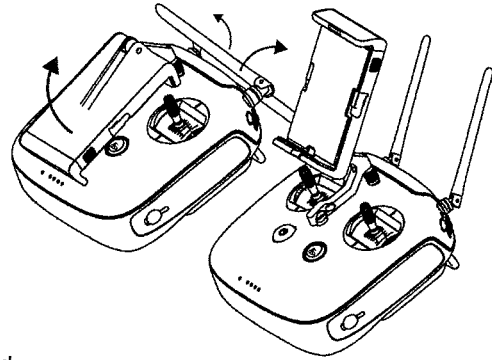

- ① Press the button on the side of the Mobile Device Holder to release the clamp.
- ② Place your mobile device into the clamp and adjust it so that the mobile device is held securely in place.
- ③ Connect your mobile device to the Remote Controller with a USB cable. Plug one end of the cable into your mobile device, and the other end into the USB port on the back of the Remote Controller.

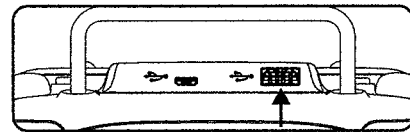

• To avoid signal interference, do not use other 2.4GHz devices when flying.

6. Flight Controls

Here are the default flight controls (Mode 2). The left stick controls altitude and rotation, while the right stick controls the forward, backward, left or right movements. The gimbal dial controls the camera's tilt.

Left Stick

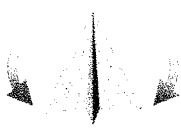
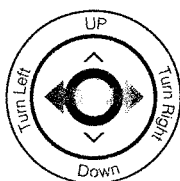
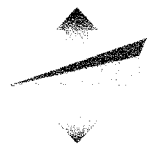
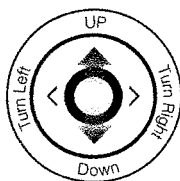

Right Stick

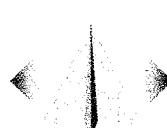
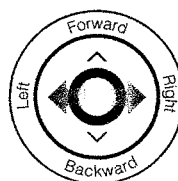
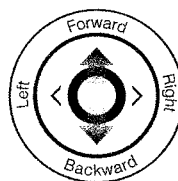

Gimbal Dial

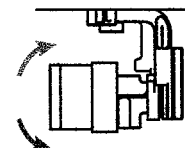

• You can customize or change these controls through the DJI Pilot app.

7. Getting Ready for Takeoff

Remove the gimbal clamp as shown on the right. Place your Phantom 3 Professional on a flat surface, in an open space, with the nose facing away from you. Then follow the steps below in this order:

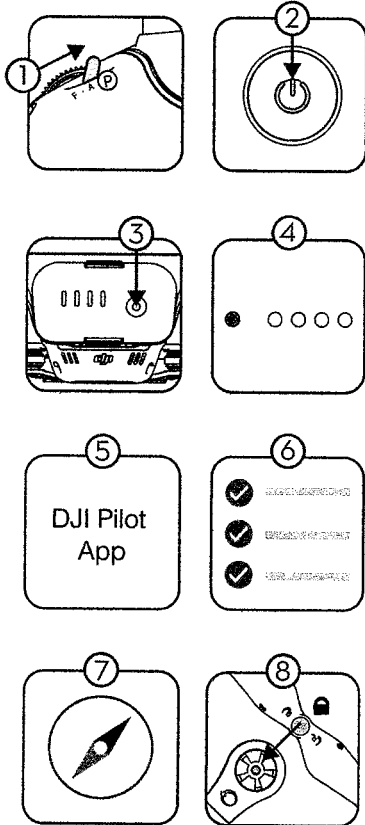
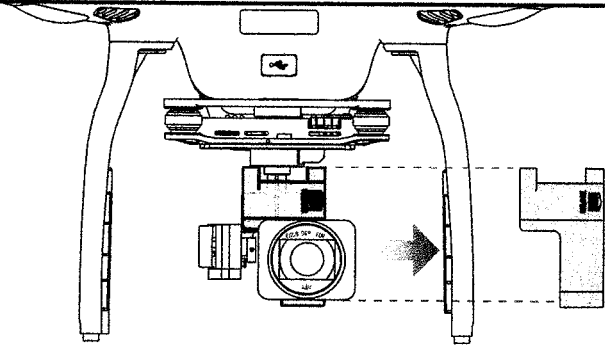

- ① Toggle the Flight Mode Switch on your Remote Controller to the right (P Mode). P Mode is Positioning Mode, A Mode is ATTI Mode, and F Mode is Function Mode.
- ② Turn on the Remote Controller by pressing the power button once, releasing it, and then pressing and holding for 2 seconds.
- ③ Insert the Intelligent Flight Battery into your Phantom 3 Professional. Turn on the battery by pressing the power button once, releasing it, and then pressing and holding for 2 seconds.
- ④ Ensure the LED on your Remote Controller is green, indicating it is ready to be used.
- ⑤ Connect your mobile device to the Remote Controller with a USB cable and launch the DJI Pilot app. Follow the instructions within the app.
- ⑥ In the app, tap 'Camera'. Ensure your Phantom 3 Professional is ready to fly by completing the on-screen Checklist. Beginner Mode is enabled by default when you launch the DJI Pilot app for the first time. The aircraft's altitude and flight distance are restricted when flying in Beginner Mode. You can disable Beginner Mode in the Settings Page of the DJI Pilot app.
- ⑦ Calibrate the compass by tapping the Aircraft Status Bar in the app and selecting 'Calibrate'. Then follow the on-screen instructions.
- ⑧ Attach the propellers with a black nut onto the motors with a black axis and spin them counter-clockwise to secure. Attach the propellers with a gray nut onto the motors with a gray axis and spin them clockwise to secure.



- Be sure to match all the propellers to motors with the correct colors and tighten by hand before flying.
- If you wish to record photos or videos, insert a Micro-SD card into the Camera's Micro-SD Card Slot.
- The Flight Mode Switch is locked in P Mode by default. Refer to the User Manual to learn how to unlock the switch and change to other modes.
- When not in P mode, the Phantom 3 Professional will only maintain altitude, not position, and will drift with wind or user input. Return to Home is not available in F mode.

8. Flight

Safe to Fly (GPS)

Before taking off, make sure the Aircraft Status Bar in the DJI Pilot app indicates 'Safe to Fly (GPS)' or 'Safe to fly (non-GPS)' if flying indoors.

• Auto Takeoff and Landing:

Your Phantom 3 Professional can automatically takeoff and land at the tap of a button in the Camera screen of the DJI Pilot app.



Tap and slide to confirm automatic takeoff. The aircraft will automatically takeoff and hover at 4 feet (1.2 meters).



Tap and slide to confirm automatic landing. The aircraft will automatically land.

• Manual Takeoff and Landing (Stick configurations are for MODE 2):

Start the motors by pulling both control sticks to the bottom inside (or outside) corners. Release the sticks once the motors start. Slowly push the left stick (throttle stick) up to takeoff.

To land, gently pull the left stick (throttle stick) down to lower the aircraft until it touches the ground. Then pull both sticks to the bottom inside corners to stop the motors.

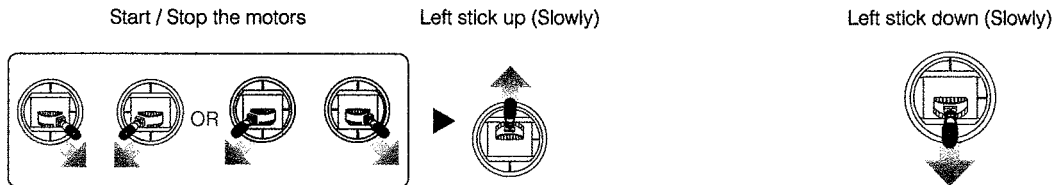

- ⚠️ • Never stop the motors mid-flight, otherwise the aircraft will crash. Only stop the motors when on the ground or as required in emergency situations to reduce the risk of damage or injury.
- You cannot takeoff if the Intelligent Flight Battery is not sufficiently charged and the Critical Low Battery Warning is active.
- The Intelligent Flight Battery must warm up if the outside temperature is low. A warning will appear in the DJI Pilot app in this scenario.
- Once spinning, the rotating propellers can be dangerous. Do not start the motors when there are people nearby and always fly in a wide-open area.
- Power off your Phantom 3 Professional before switching off the Remote Controller after landing.

• Return to Home:

1. Press and hold the Return to Home Button on your Remote Controller until the LED surrounding the button starts blinking white and starts beeping. Your Phantom 3 Professional will return to the set Home Point. Press the button once to stop the procedure.
2. The DJI Pilot app will warn you if your Phantom 3 Professional's battery level falls under a certain level. This warning threshold can be set in the app. The aircraft will land immediately if the battery power reaches a critical level and the Critical Low Battery Level Warning appears.
3. Failsafe: The Phantom 3 Professional will enter Return to Home Mode if the signal to the Remote Controller is lost.

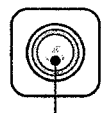

RTH Button



The app's RTH Button



- While returning home, you can still control your Phantom 3 Professional's altitude to avoid any obstacles.

Appendix

Aircraft Status Indicators

- ☀️ Slowly: Safe to fly, GPS working
- ☀️ x2 Continuously: Vision Positioning system working, no GPS
- ☀️ Slowly: P-ATTI or ATTI Mode
- ☀️ Quickly: Not connected to the Remote Controller
- ☀️ Slowly: Low Battery Level Warning
- ☀️ Quickly: Critical Low Battery Level Warning
- Solid: Critical error
- ☀️ / ☀️ Blinking Alternately: Compass calibration required

Remote Controller Status LED

- Remote Controller is functioning normally, but is not connected to the aircraft.
- Remote Controller is functioning normally and is connected to the aircraft.
- ☀️ B-B-B... Aircraft Low Battery Level Warning or Remote Controller error.
- B—B—... Remote Controller has been idle for 5 minutes.

Camera Controls

- Adjust the camera parameters using the Camera Settings Dial on the Remote Controller or through the DJI Pilot app. Press the Shutter Button or Video Recording Button to capture photos or record videos.
- Adjust the gimbal's tilt using the Gimbal Dial.
- Download photos and videos from the Micro-SD card to your mobile device through the DJI Pilot app. You can also use a SD-card reader to export files to your computer.



PHANTOM 3

PROFESSIONAL

ADVANCED

SAFETY GUIDELINES AND DISCLAIMER

V1.0 2015.4



NOTICE

All instructions and other collateral documents are subject to change at the sole discretion of SZ DJI TECHNOLOGY CO., LTD. For up-to-date product information, visit <http://www.dji.com> and click on the Phantom 3 product page.

Glossary

The following terms are used throughout the product literature to indicate various levels of potential harm when operating this product:

NOTICE NOTICE: Procedures, which if not properly followed, create a possibility of physical property damage AND a little or no possibility of injury.

CAUTION CAUTION: Procedures, which if not properly followed, create the probability of physical property damage AND a possibility of serious injury.

WARNING WARNING: Procedures, which if not properly followed, create the probability of property damage, collateral damage, and serious injury OR create a high probability of superficial injury.

 **WARNING** Read the **ENTIRE** user manual to become familiar with the features of this product before operating. Failure to operate the product correctly can result in damage to the product or personal property and cause serious injury. This is a sophisticated product. It must be operated with caution and common sense and requires some basic mechanical ability. Failure to operate this product in a safe and responsible manner could result in injury or damage to the product or other property. This product is not intended for use by children without direct adult supervision. Do not use with incompatible components or alter this product in any way outside of the documents provided by SZ DJI TECHNOLOGY CO., LTD. These Safety Guidelines contain instructions for safety, operation and maintenance. It is essential to read and follow all of the instructions and warnings in the user manual, prior to assembly, setup or use, in order to operate the product correctly and avoid damage or serious injury.

Age Recommendation: Not for children under the age of 18. This is not a toy.

Pre-flight Checklist

- 1) Ensure that you are using only genuine parts and that all parts are in mint condition.
- 2) Ensure the remote controller, Intelligent Flight Battery, and mobile device are fully charged.
- 3) Ensure that there is no foreign object stuck to the camera lens, the micro-SD card has been inserted into the camera, and the gimbal can rotate freely before powering it on.
- 4) Ensure the propellers are securely mounted onto the motors, and the motors can start and function normally.
- 5) Follow the on-screen instructions to calibrate the compass.
- 6) Ensure the DJI Pilot app and aircraft's firmware have been upgraded to the latest version.
- 7) Ensure the your flight area is outside the No-Fly Zones and flight conditions are suitable for flying the aircraft.
- 8) Be sure that you are NOT flying under the influence of alcohol, drugs or any substance that may impair your cognitive abilities.
- 9) Be familiar with the selected flight mode and understand all safety functions and warnings.
- 10) Be sure to observe all local regulations, obtain appropriate authorizations, and understand the risks.
REMEMBER: It is solely your responsibility to comply with all flight regulations.

Contents

NOTICE	1
Glossary	1
Pre-flight Checklist	1
Disclaimer and Warning	3
FCC Compliance and Advisory	3
IMPORTANT NOTE: FCC Radiation Exposure Statement	3
FCC Class B Information	3
Before You Begin	5
Individual Parts	5
Regarding Genuine and Functional Parts	5
Remote Controller	5
Camera	6
Gimbal	6
Compass	6
Propulsion Systems	7
DJI Pilot App	8
Firmware	8
Product Care	10
Storage and Transportation	10
Maintenance and Upkeep	10
Flight Condition Requirements	11
Weather Conditions and Surrounding Environment	11
Interference with Flight Controller, Communications, and Positioning Systems	11
Operating the Aircraft Responsibly	11
Flight Modes, Functions and Warnings	13
Flight Modes	13
Failsafe and Return to Home	13
Low Battery	14
Vision Positioning System	14
Compliance with Regulations & No-Fly Zones	15
Regulations	15
No-Fly Zones	16

Disclaimer and Warning

This product is NOT a toy and is not suitable for children under the age of 18. Adults should keep the Phantom 3 out of the reach children and exercise caution when operating this aircraft in the presence of children.

This product is a flying camera that offers easy flight when in good working order as set forth below. Visit <http://www.dji.com> for the most current instructions and warnings and <http://knowbeforeyoufly.org/> for more information about flight safety and compliance.

The information in this document affects your safety and your legal rights and responsibilities. Read this entire document carefully to ensure proper configuration before use. Failure to read and follow the instructions and warnings in this document may result in product loss, serious injury to you, or damage to your aircraft.

By using this product, you hereby signify that you have read this disclaimer carefully and that you understand and agree to abide by the terms and conditions herein. You agree that you are solely responsible for your own conduct while using this product, and for any consequences thereof. You agree to use this product only for purposes that are proper and in accordance with all applicable laws, rules, and regulations, including international and domestic airspace regulations, and all terms, precautions, practices, policies and guidelines DJI has made and may make available. You further understand and agree that your data including, but not limited to, flight telemetry data and operation records could be uploaded to and maintained on a DJI-designated server under certain circumstances.

DJI accepts no liability for damage, injury or any legal responsibility incurred directly or indirectly from the use of this product. The user shall observe safe and lawful practices including, but not limited to, those set forth in these Safety Guidelines.

FCC Compliance and Advisory

This device complies with part 15 of FCC Rules. Operation is subject to the following two conditions: (1) this device may not cause harmful interference, and (2) this device must accept any interference received, including interference that may cause undesired operation.

Any changes or modifications not expressly approved by the party responsible for compliance could void the user's authority to operate the equipment.

IMPORTANT NOTE: FCC Radiation Exposure Statement

This equipment complies with FCC radiation exposure limits set forth for an uncontrolled environment. This equipment should be installed and operated with a minimum distance of 20 cm between the radiator and your body. This transmitter must not be co-located or operate in conjunction with any other antenna or transmitter.

FCC Class B Information

This equipment has been tested and found to comply with the limits for a Class B digital device, pursuant to part 15 of the FCC Rules. These limits are designed to provide reasonable protection against harmful

interference in a residential installation. This equipment generates, uses, and can radiate radio frequency energy and, if not installed and used in accordance with the instructions, may cause harmful interference to radio communications. However, there is no guarantee that interference will not occur in a particular location. If this equipment does cause harmful interference to radio or television reception, which can be determined by turning the equipment off and on, the user is encouraged to try to correct the interference by one or more of the following measures:

- Reorient or relocate the receiving antenna;
- Increase the separation between the equipment and receiver;
- Connect the equipment into an outlet on a circuit different from that to which the receiver is connected;
- Consult the dealer or an experienced radio/TV technician for help;

DJI hereby declares that this product is in compliance with the essential requirements and other relevant provisions of Directive 1995/5/EC.

DJI reserves the right to update this disclaimer and the Safety Guidelines. Please visit www.dji.com and check your email periodically for the latest version. This disclaimer is made in various language versions: in the event of divergence among different versions, the English version shall prevail.

Before You Begin

The following documents have been produced to help you safely operate and make full use of your Phantom 3:

In the Box

Phantom 3 Professional / Advanced Safety Guidelines and Disclaimer

Phantom 3 Professional / Advanced Intelligent Flight Battery Safety Guidelines

Phantom 3 Professional / Advanced Quick Start Guide

Phantom 3 Professional / Advanced User Manual

Check all of the included parts listed in the *Phantom 3 In the Box* document and read the *Phantom 3 Safety Guidelines* before flight. Then prepare for your first flight by using the *Phantom 3 Quick Start Guide* and watching all of the tutorial videos on DJI's official website (<http://www.dji.com>). If you have questions, refer to the *Phantom 3 User Manual* in the DJI Pilot app or on DJI's official website for more comprehensive information. Make sure you fully understand the functionality of each individual part, the flight condition requirements, the key contingency warning functions/systems, and all government regulations before each flight. If you have any questions or problems during the assembly, maintenance or use of this product, please contact DJI or a DJI authorized dealer.

Individual Parts

Regarding Genuine and Functional Parts

⚠ WARNING

To avoid component malfunction, serious injury, and property damage, observe the following rules:

- 1) Use only genuine DJI parts or parts certified by DJI. Unauthorized parts or parts from non-DJI certified manufacturers may cause system malfunctions and compromise safety.
- 2) Ensure there are no foreign objects (such as water, oil, soil, sand, etc.) inside of the aircraft or its components.
- 3) Ensure the aircraft and its components – including but not limited to the remote controller, camera, gimbal, compass, propulsion system, and battery – are all in good working order, damage-free, and functioning well. Refer to the remaining sections in this document for more details on how to ensure the functionality of these components.

Remote Controller

NOTICE

- 1) Ensure the remote controller is fully charged before each flight.
- 2) If the remote controller is powered on and has NOT been used for 5 minutes, it will sound an alert. After 10 minutes it will automatically power off. Move the sticks or perform some other action to cancel the alert.
- 3) Adjust the clamp of the mobile device holder to allow a firm grip on your mobile device.
- 4) Ensure the mobile device holder is firmly in place and does not slip.
- 5) Ensure the antennas of the remote controller are unfolded and adjusted to the proper position to achieve optimal transmission quality.
- 6) Repair or replace the remote controller if damaged. A damaged remote controller antenna will greatly

decrease performance.

- 7) Linking is required if you wish to replace your remote controller or receiver or add a new remote controller. Refer to the User Manual for details.

Camera

CAUTION

To avoid possible serious injury and property damage, observe the following rule:

- 1) Do NOT block any ventilation holes on the camera as the heat generated may hurt you and damage the device.

NOTICE

- 1) Check camera settings before use to make sure you can adjust them to fit your needs.
- 2) Test the camera by shooting a few test images and check that it is operating correctly before shooting important pictures or videos.
- 3) Do NOT remove the micro-SD card from the camera when it is powered on.
- 4) Photos or videos cannot be transmitted or copied from the camera if the Intelligent Flight Battery is powered off.
- 5) Be sure to power off the Intelligent Flight Battery correctly, otherwise your camera parameters will NOT be saved and any recorded videos may be damaged. NOTE: Regardless of the reason, DJI will not be responsible for any failure of an image or video to be recorded or having been recorded in a way that is not machine readable.

Gimbal

NOTICE

- 1) Precision elements in the gimbal may be damaged in a collision or impact, which may cause the gimbal to function abnormally.
- 2) Do NOT apply external force to the gimbal after the gimbal is powered on.
- 3) Do NOT add any payloads to the gimbal, as this may cause the gimbal to function abnormally or even lead to motor damage.
- 4) Remove the gimbal clamp before powering on the gimbal. Re-install the gimbal clamp to secure the gimbal's position if you are going to store the aircraft for an extended period.

Compass

CAUTION

To avoid possible serious injury and property damage, observe the following rule:

- 1) Land immediately when severe drifting occurs in flight, i.e., the aircraft does NOT fly in straight lines.

NOTICE

- 1) Ensure the compass is calibrated before every flight. Failure to calibrate may lead to poor flight performance or a crash.
- 2) Do NOT attempt to calibrate your compass where there is a chance of strong magnetic interference.

This includes areas where there are massive metal objects, parking structures, steel reinforcements underground, or under bridges.

- 3) Do NOT carry ferromagnetic materials with you during calibration, such as keys or mobile phones.
- 4) The compass should always be calibrated when moving from indoor spaces to outdoor spaces.
- 5) If the rear LEDs show a solid red light, compass calibration has failed. Please recalibrate.
- 6) After successful calibration, the compass may become abnormal when you place the aircraft on the ground. This may be because of underground magnetic interference. Move the aircraft to another location and try again.
- 7) When to recalibrate
 - a) When compass data is abnormal, and the Aircraft Status Indicator is blinking red and yellow.
 - b) When flying in a new location, or a location that is different from your last flight.
 - c) When the mechanical structure of the aircraft has changed, i.e. new mounting position of the compass.
 - d) When severe drifting occurs in flight, i.e. the aircraft does NOT fly in straight lines.

Propulsion Systems

WARNING

To avoid serious injury to yourself or others, which may be caused by the rotating propellers and motors, observe the following rules:

Propellers

- 1) Do NOT use aged, chipped, or broken propellers.
- 2) Always power off the aircraft before touching the propellers.
- 3) Be aware of the sharp edges of the propellers when mounting or removing the propellers. Wear gloves or take other protective measures when touching the propellers.
- 4) Whenever necessary, use tools (e.g., wrench, screwdriver, pliers, etc.) to remove or install the propellers.
- 5) Ensure the propellers are securely mounted to prevent them from falling off the motors.
- 6) Do NOT turn on the motors when propellers are mounted and there are other people or animals in the immediate vicinity.

Motors

- 1) Ensure the motors are securely mounted and rotating smoothly.
- 2) Do NOT attempt to modify the structure of the motors.
- 3) Do NOT touch or let your hands or body come in contact with the motors after flight as they may be hot.

CAUTION

To avoid possible serious injury and property damage, observe the following rules:

- 1) Do NOT block any of the ventilation holes on the motors.
- 2) Do NOT block any of the ventilation holes on the frame arm of the aircraft.

NOTICE

Motors

- 1) Keep the motors free of dust.
- 2) If a motor is stuck and unable to rotate freely, execute the CSC (Combination Stick Command) to stop the motors immediately.

Electronic Speed Controllers

- 1) Ensure the ESCs sound a normal tune when powered on.

DJI Pilot App

NOTICE

- 1) Be sure to fully charge your tablet or mobile device before launching the DJI Pilot app. A tablet is recommended for a better user experience.
- 2) If you are using a phone as your mobile display device, be sure to continue flying safely when the phone receives an incoming call. Do NOT accept phone calls during flight.
- 3) Read all prompted safety tips, warning messages, and disclaimers carefully. Be familiar with the related regulations in your area. You are solely responsible for being aware of all relevant regulations and flying in a way that is compliant.
 - a) Read and understand the warning messages before using the Auto-take off and Auto-landing features.
 - b) Read and understand the warning message and disclaimer before setting the altitude beyond the default limit.
 - c) Read and understand the warning messages and disclaimer before switching between flight modes.
- 4) Land your aircraft immediately if there is an alert shown on the app.
- 5) Examine and check all warning messages on the checklist displayed in the app prior to each flight.
- 6) Use the in-app simulator to practice your flight skills if you have never operated the aircraft or if you do not have sufficient experience to be comfortable operating the aircraft.
- 7) Beginner Mode is enabled by default when you launch the DJI Pilot app for the first time. The aircraft's altitude and flight distance is restricted when flying in Beginner Mode. We recommend you fly in Beginner Mode to perfect your flight skills. Operate the actual aircraft only after you are confident that you have mastered adequate flight skills.
- 8) Cache the map data of the area where you intend to fly the aircraft by connecting to the Internet before each flight.

Firmware

⚠ WARNING

To avoid serious injury to children and animals, observe the following rule:

- 1) **Keep children and animals at a safe distance during any firmware upgrade, system calibration, and parameter setting procedures.**

NOTICE

- 1) For safety, always update the firmware to the latest version when an upgrade notification is shown in the DJI Pilot app.
- 2) Firmware upgrade notifications will prompt you to proceed with an update immediately or to update the firmware within three days. If you choose to ignore the current firmware update, you are required to accept the prompted disclaimer. You further understand and agree that the data including but not limited to flight telemetry data and user selection records may be uploaded to and maintained on a DJI-designated server.
- 3) Be sure to download the firmware package file from the official DJI website. Verify the firmware package file's integrity before upgrading.

- 4) Be sure to update the remote controller's firmware to the latest version after you update the aircraft's firmware.
- 5) The remote controller may become unlinked from the aircraft after updating. Re-link the remote controller and aircraft.
- 6) Be sure to check all connections and remove the propellers from the motors before performing the firmware update.
- 7) Ensure there is only one firmware package file stored on your SD card.
- 8) Only storage devices that are formatted for FAT32 and exFAT file systems are supported for aircraft and remote controller firmware updates.
- 9) Delete any automatically generated `.txt` files on the SD card when updating multiple remote controllers.

Product Care

Storage and Transportation

⚠ WARNING

To avoid serious injury to children and animals, observe the following rule:

- 1) Small parts, such as cables and straps, are dangerous if swallowed. Keep all parts out of reach of children and animals.

NOTICE

- 1) Store the Intelligent Flight Battery and remote controller in a cool, dry place away from direct sunlight to ensure the built-in LiPo battery does NOT overheat. Recommended storage temperature: between 22°C and 28°C for storage periods of more than three months. Never store in environments outside the temperature range of -20°C to 45°C.
- 2) Do NOT allow the camera to come into contact with, or become immersed in, water or other liquids. If it gets wet, wipe dry with a soft, absorbent cloth. Turning on an aircraft that has fallen into water may cause permanent component damage. Do NOT use substances containing alcohol, benzene, thinners or other flammable substances to clean or maintain the camera. Do NOT store the camera in humid or dusty areas.
- 3) Do NOT connect this product to any USB interface that is older than version 2.0. Do NOT connect this product to any "power USB" or similar devices.

Maintenance and Upkeep

NOTICE

- 1) Check every part of the aircraft after any crash or violent impact. If you have any problems or questions, please contact a DJI authorized dealer.
- 2) Regularly check the Battery Level Indicators to see the current battery level and overall battery life. When the battery life reaches 0%, it can no longer be used.

Flight Condition Requirements

Weather Conditions and Surrounding Environment

⚠ WARNING

The aircraft is designed to operate in good to moderate weather conditions. To avoid collision, serious injury and property damage, observe the following rules:

- 1) Do NOT use the aircraft in severe weather conditions. These include wind speeds exceeding 10 m/s, snow, rain, smog, heavy wind, hail, lightning, tornadoes or hurricanes.
- 2) Keep the aircraft at least 10 meters (30 feet) away from obstacles, people, animals, buildings, public infrastructure, trees, and bodies of water when in flight. Stay even further away from the above objects as your altitude increases.
- 3) Be EXTRA cautious when operating the aircraft indoors.

NOTICE

- 1) Aircraft and battery performance is subject to environmental factors such as air density and temperature.
 - a) Be very careful when flying 20,000 feet (6,000 meters) or more above sea level as battery and aircraft performance may be reduced.
- 2) Do NOT use the aircraft near accidents, fire, explosions, floods, tsunamis, avalanches, landslides, earthquakes, dust, or sandstorms.

Interference with Flight Controller, Communications, and Positioning Systems

NOTICE

- 1) Fly in open areas. Tall buildings or steel structures may affect the accuracy of the on-board compass and block the GPS signal.
- 2) Avoid interference between the remote controller and other wireless equipment. Make sure to turn off the Wi-Fi on your mobile device.
- 3) Do NOT fly near areas with magnetic or radio interference. These include but are NOT limited to: high voltage lines, large scale power transmission stations or mobile base stations and broadcasting towers. Failing to do so may compromise the transmission quality of this product or cause remote controller and video transmission errors which may affect flight orientation and location accuracy. The aircraft may behave abnormally or go out of control in areas with too much interference.

Operating the Aircraft Responsibly

⚠ WARNING

To avoid serious injury and property damage, observe the following rules:

- 1) Make sure you are NOT drunk, taking drugs, under the influence of anesthesia, or suffering from dizziness, fatigue, nausea or any other conditions, whether physical or mental, that could impair your ability to operate the aircraft safely.
- 2) Do NOT perform the Combination Stick Commands when aircraft is in midair, otherwise the motors will stop.

- 3) **Upon landing, power off the aircraft first, then switch off the remote controller.**
- 4) **Do NOT drop, launch, fire or otherwise project any dangerous payloads on or at any buildings, persons or animals, or which could cause personal injury or property damage.**

NOTICE

- 1) Make sure you have been sufficiently trained and are fully aware of any contingency plans before accidents happen.
- 2) Make sure you have a flight plan and never fly the aircraft recklessly.
- 3) Respect the privacy of others when using the camera. Make sure you comply with local privacy laws, regulations, and moral standards.
- 4) Do NOT use this product for any reason other than general personal use. Do NOT use it for any illegal or inappropriate purpose (such as spying, military operations, or unauthorized investigations).
- 5) Do NOT use this product to defame, abuse, harass, stalk, threaten or otherwise violate the legal rights (such as the right of privacy and publicity) of others.
- 6) Do NOT trespass into private property of others.

Flight Modes, Functions and Warnings

Flight Modes

⚠ WARNING

To avoid serious injury and property damage, observe the following rule:

- 1) Do NOT switch from P mode to either A mode or F mode unless you are sufficiently familiar with the aircraft's behavior for each flight mode, since disabling GPS may result in being unable to land the aircraft safely.

NOTICE

P mode is preferred for most flying scenarios. Users can switch to A mode where and when P mode is unavailable. Be aware that some features are NOT available for A mode, and therefore be EXTRA cautious when flying in A mode.

- 1) P mode (Positioning): P mode works best when the GPS signal is strong. There are three different states of P mode, which will be automatically selected by the Phantom 3 depending on GPS signal strength and Vision Positioning sensors:
 - a) P-GPS: GPS and Vision Positioning are both available, and the aircraft is using GPS for positioning.
 - b) P-OPTI: If GPS is NOT available, the aircraft will use the Vision Positioning System to hover accurately. Note that the Vision Positioning System may NOT work properly when the Phantom 3 is flying over water, over surfaces without a clear pattern, or in a low light environment.
 - c) P-ATTI: When neither GPS nor Vision Positioning is available, the aircraft is using only its barometer for positioning, so only altitude is controlled.
- 2) A mode (Attitude): The GPS and Vision Positioning System are NOT used for positioning. The aircraft only uses its barometer to maintain altitude. If it is still receiving a GPS signal, the aircraft can automatically return home if the Remote Controller signal is lost and if the Home Point has been recorded successfully.
- 3) F mode (Function): Intelligent Orientation Control (IOC) is activated in this mode. Ensure you are familiar with IOC functions before use.

If you intend to switch to modes that disable GPS assistance (e.g., A mode), you are required to accept the prompted disclaimer to enable this function. If this function is enabled, you further understand and agree that data including but not limited to flight telemetry data and function records could be uploaded to and maintained on a DJI designated server.

Failsafe and Return to Home

NOTICE

- 1) The Return to Home feature will NOT work if the GPS signal is insufficient or if GPS is not active.
- 2) Press the RTH (Return to Home) Button on the remote controller to bring the aircraft back to the Home Point instead of turning off the remote controller.
- 3) Tall buildings may adversely affect the Failsafe function. Please adjust the aircraft location, altitude and speed while returning home to avoid obstacles.
- 4) Make sure to always fly the aircraft within the transmission range of the remote controller.
- 5) Only use the Failsafe and Return to Home functions in case of emergency, as they may be affected by the weather, the environment, or any nearby magnetic fields.

- 6) The aircraft cannot avoid obstacles during the Failsafe RTH; therefore it is important to set an appropriate Failsafe altitude before each flight.
- 7) When flying indoors, the aircraft cannot perform precision hovering when flying above the surfaces that do not have a clear pattern. Refer to the "Vision Positioning System" section for complete indoor flying criteria.

Low Battery

NOTICE

- 1) When the Critical Battery Level Warning activates and the aircraft is descending automatically, you may push the throttle up to maintain the aircraft's altitude and navigate it to a more appropriate location for landing.
- 2) When battery warnings are triggered, promptly bring the aircraft back to the Home Point or land to avoid losing power during flight and causing damage to the aircraft, property, animals, and people.

Vision Positioning System

NOTICE

- 1) The Vision Positioning System cannot work properly over surfaces that do NOT have pattern variations. The effective altitude for the Vision Positioning System to function correctly is less than 2.5 meters above ground level (AGL).
- 2) The Vision Positioning System may NOT function properly when the aircraft is flying over water.
- 3) Keep your pets away from the aircraft when the Vision Positioning System is activated, as the sonar sensors emit a high frequency sound that is only audible to some pets.
- 4) Note that the Vision Positioning System may NOT function properly when the aircraft is flying too fast or too low.
- 5) Operate the aircraft cautiously when in any of the following situations:
 - a) Flying over monochrome surfaces (e.g., pure black, pure white, pure red, pure green).
 - b) Flying over highly reflective surfaces;
 - c) Flying at high speeds (over 8m/s at 2 meters or over 4m/s at 1 meter);
 - d) Flying over water or transparent surfaces;
 - e) Flying over moving surfaces or objects;
 - f) Flying in an area where the lighting changes frequently or drastically;
 - g) Flying over extremely dark (lux < 10) or bright (lux > 10,000) surfaces;
 - h) Flying over surfaces that can absorb sound waves (e.g., thick carpet).
 - i) Flying over surfaces without clear patterns or texture;
 - j) Flying over surfaces with identical repeating patterns or textures (e.g. tiles with same design);
 - k) Flying over inclined surfaces that will deflect sound waves away from the aircraft
- 6) In the event of loss of the remote controller's signal, the aircraft will hover for 8 seconds and then auto-land if it is in "P" mode.

Compliance with Regulations & No-Fly Zones

Regulations

⚠ WARNING

To avoid non-compliant behavior, serious injury and property damage, observe the following rules:

- 1) Do NOT operate in the vicinity of manned aircraft, regardless of altitude. (Land immediately if necessary)
- 2) Do NOT fly the aircraft in densely populated areas, including cities, sporting events, exhibitions, performances, etc.
- 3) Do NOT fly the aircraft above the authorized altitude. Remain well clear of and do NOT interfere with manned aircraft operations. Be aware of and avoid other aircraft and obstacles at all times.

CAUTION

To avoid non-compliant behavior, serious injury and property damage, observe the following rules:

- 1) Do NOT fly the aircraft within, near, or otherwise inside no-fly zones specified by local laws and regulations. The no-fly zone list includes: airports, borders between two sovereign countries or regions, major cities, etc., and is continuously updated.
- 2) Do NOT fly the aircraft above the authorized altitude
- 3) ALWAYS keep your aircraft within visual line of sight (VLOS), and use an observer to assist if needed.
- 4) NEVER use the aircraft to carry illegal or dangerous goods/payloads.

NOTICE

- 1) Make sure you understand the nature/type of your flight operation (such as for recreation, for public use, or for commercial use) and have obtained corresponding approval and clearance from the related government agencies before flight. Consult with your local regulators for comprehensive definitions and specific requirements. For users operating their aircraft in the United States, please first visit <http://www.knowbeforeyoufly.org/> and take action appropriate to your circumstances.
- 2) Please note that remote controlled aircraft may be banned from conducting commercial activities in certain countries and regions.
- 3) Do NOT fly around sensitive infrastructure or property such as power stations, water treatment facilities, correctional facilities, heavily traveled roadways, government facilities, military zones, etc.
- 4) Respect the privacy of others when using the camera. Do NOT conduct surveillance operations such as image capture or video recording on any person, entity, event, performance, exhibition, and property without authorization or where there is an expectation of privacy, even if the image or video is captured for personal use.
- 5) Please be advised that in certain areas, the recording of images and videos from events, performances, exhibitions, or commercial properties by means of a camera may contravene copyright or other legal rights, even if the image or video was shot for personal use. In addition, aircraft are banned from conducting commercial activities in certain countries and regions. Check and follow all local laws and ordinances before flying as those rules may differ from those stated here.

No-Fly Zones

NOTICE

DJI always stresses safety during flight, and has therefore developed various aids to help users comply with local rules and regulations while flying. We strongly recommend that you update the firmware to the latest version to ensure the the following features are fully updated:

No-Fly Zones

- 1) No-Fly Zones include but are not limited to major airports around world, borders between two sovereign countries or regions, major cities/regions, etc.
- 2) The complete list of No-Fly Zones is listed on the official DJI website at <http://flysafe.dji.com/no-fly> and is subject to periodic updates in line with the latest regulatory requirements without prior notice.
- 3) Some No-Fly Zones are comprised of several zones. Each zone features circles of various sizes. The aircraft will NOT be able to take off in the inner most zone of the No-Fly Zone, and will descend to the specified altitude when it approaches the edge of the inner most zone. Ground station functionality is disabled when the aircraft is within a No-Fly Zone.
- 4) Users are NOT able to set up waypoints within No-Fly Zones.

Altitude Limit

- 1) Fly NO higher than 120 meters (400 feet) above ground level and stay away from any surrounding obstacles.

If you intend to fly above the default altitude limit, you are required to accept the prompted disclaimer to enable the new altitude limit. If a new altitude limit is set, you further understand and agree that data including but not limited to flight telemetry data and altitude limit changes could be uploaded to and maintained on a DJI-designated server.

This content is subject to change.

**Download the latest version from
www.dji.com/support**



If you have any questions about this document, please contact DJI by sending a message to DocSupport@dji.com.

© 2015 DJI. All Rights Reserved.



PHANTOM PILOT TRAINING GUIDE

Earning Your Stripes

Learn More: www.dji.com



CAUTION

AGES

18+



WARNING!

Rotating parts may cause injury

This product is not suitable for people under the age of 18. Please carefully read the “Quick Start Guide”, “User Guide”, disclaimer, and fully watch the “Quick Start Videos” before using the PHANTOM. Users should make every effort to fly regularly in order to improve their flight skills as an advanced level pilot (★★★) . Please fly safely and responsibly.

Please follow these guidelines prior to flying your Phantom:

- 1 Always turn on the Remote Controller prior to turning on the Phantom.
- 2 Toggle S1, S2 to the top.
- 3 Be sure there are no distractions when you’re flying.
- 4 When starting your training, be sure you are in a very large open area. Be aware of your surroundings. Always fly in areas void of obstacles and away from traffic and people.
- 5 Before actually taking off, be sure you have calibrated the compass and you have full GPS satellite reception (Slow Continuous Green Flashing).
- 6 Never fly over 400 feet.
- 7 During training, stay behind your imaginary barrier and never fly behind yourself.
- 8 When in doubt, gently pull down on the throttle stick and land.
- 9 DO NOT PANIC.

The aircraft camera should face **AWAY** from the pilot before takeoff.



CAUTION

DO NOT fly the Phantom within a radius of 2 meters.



FORBIDDEN

DO NOT touch the propellers after the Phantom has been started.



NO TOUCH

Basic Flight Maneuvers (★)

1 Take off and land with battery facing you.

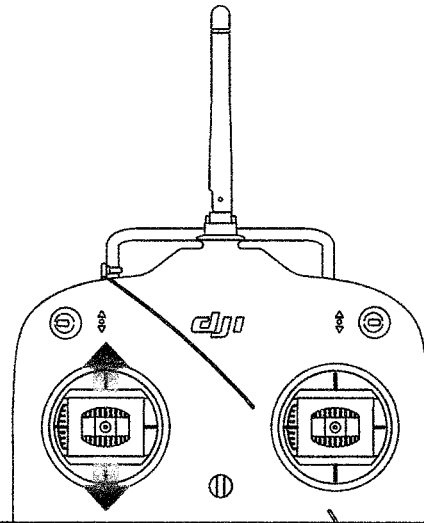
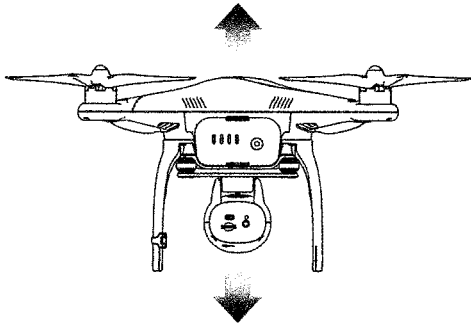

2 Hover in one spot keeping battery facing you, make sure to control Left/Right/Forward/Back movement.

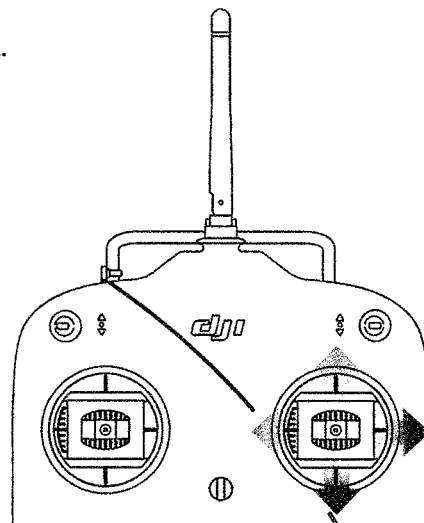
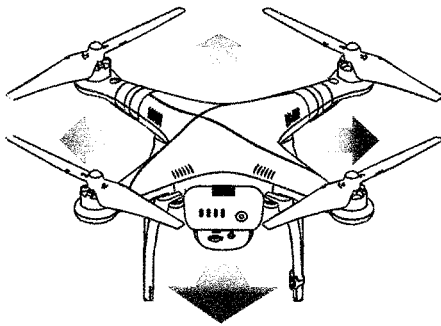

3 Rotate left, rotate right but try to keep the battery pointed at yourself.

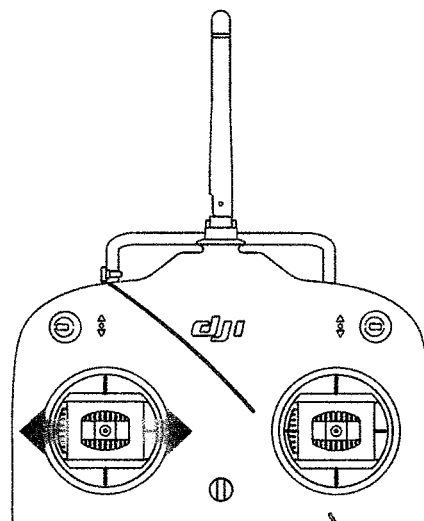
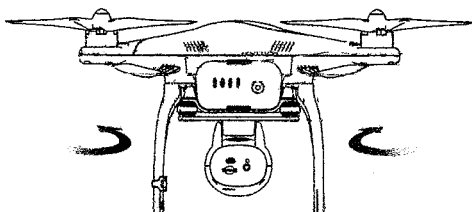

Basic Flight Maneuvers (★)

4 Slowly fly forward/back/left/right with back of Phantom pointed at yourself.

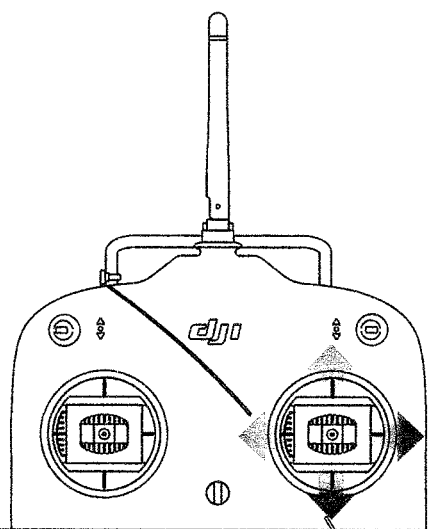
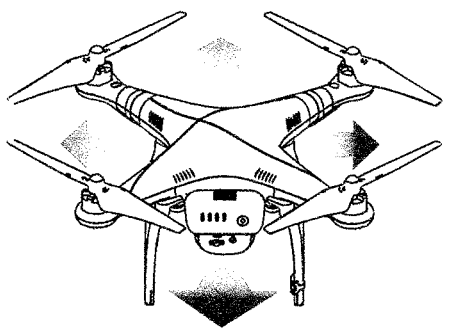

5 Fly forward to a spot 20-30 feet away. Then fly back keeping the battery pointed at yourself.

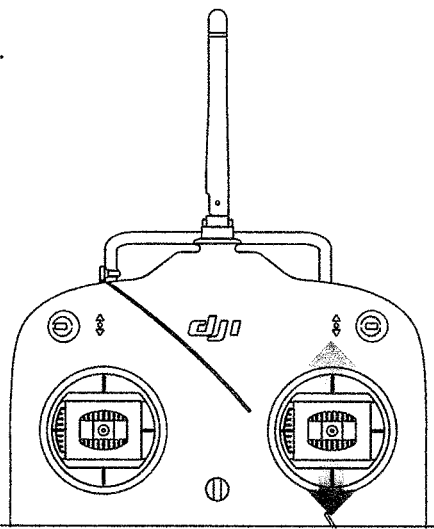
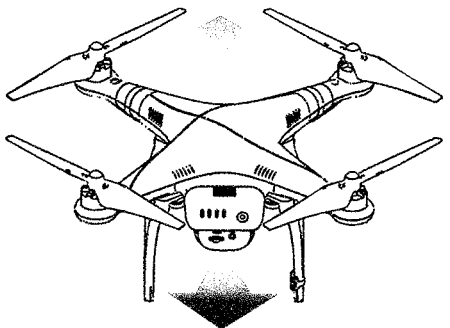

6 Mark a spot (B) on the ground 10ft away from the Phantom's take off point. Hover and fly towards that spot and land at the spot (B). Then go back into a hover and bring the Phantom back to its original position (A) and land again.

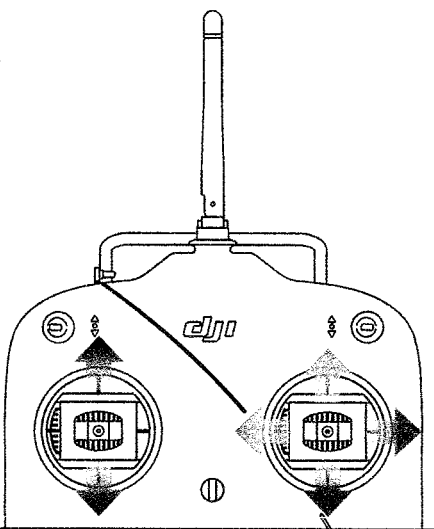
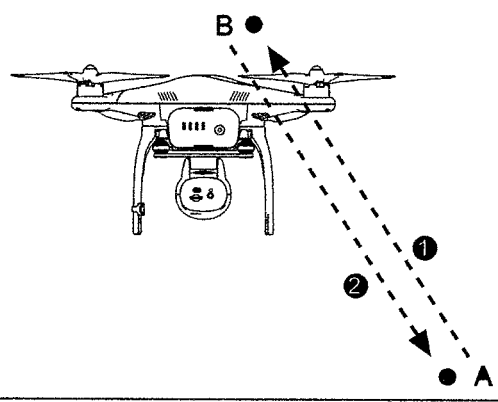

Basic Flight Maneuvers (★)

- 7** Fly left 10ft away from your take-off point, then fly right 10ft from your take-off point all while keeping battery pointed at yourself.

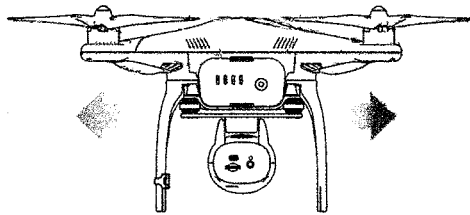

3 meters

3 meters

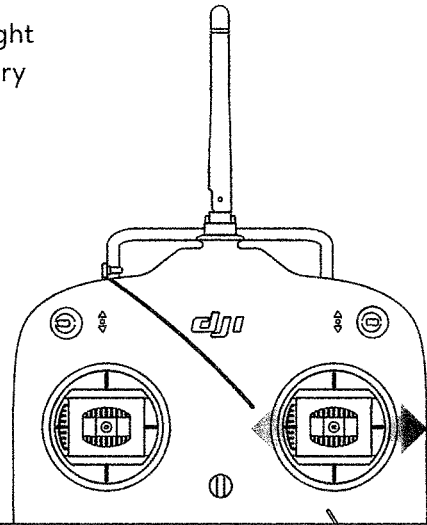

- 8** Then, while keeping the camera pointed forward, fly a 4 point square box formation going clockwise. Be sure to be in control and stop and hover in place at each point before proceeding to the next point.

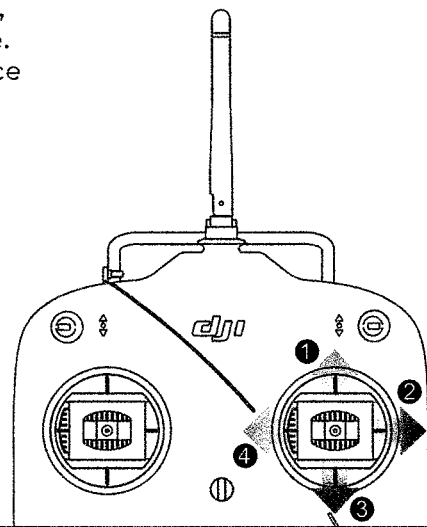
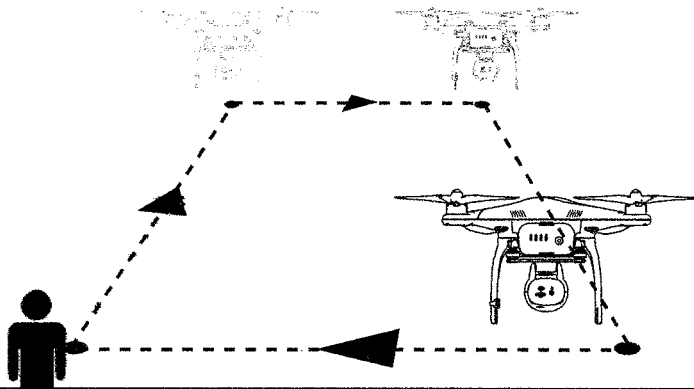

- 9** Do the same as above but fly the 4 point box formation counter-clockwise. Be sure to be in control and stop and hover in place at each point before proceeding to the next point.

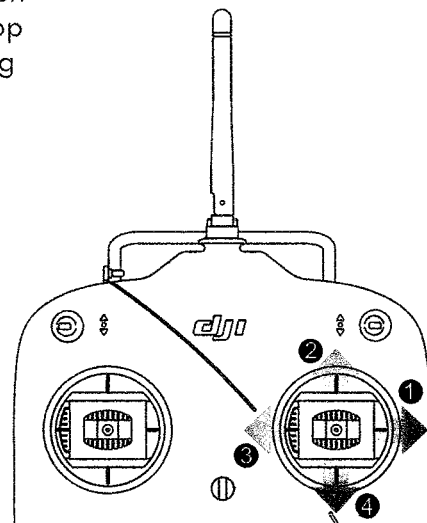
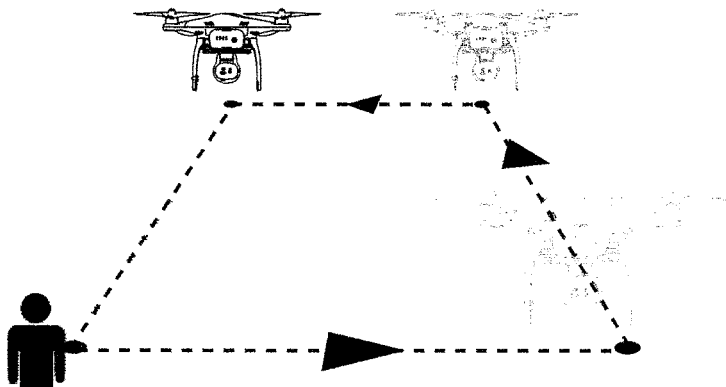

Skilled Flight Maneuvers (★★★)

- 1** In a hover, starting with the battery pointed at yourself, rotate 360 degrees clockwise.

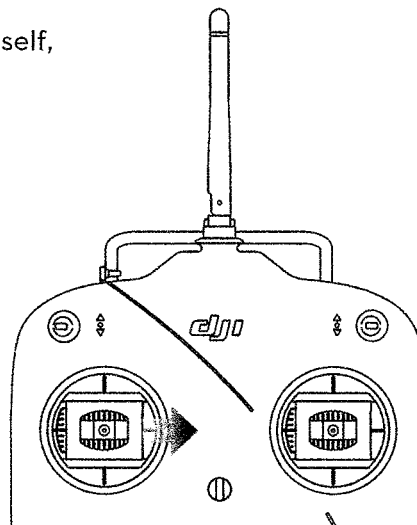
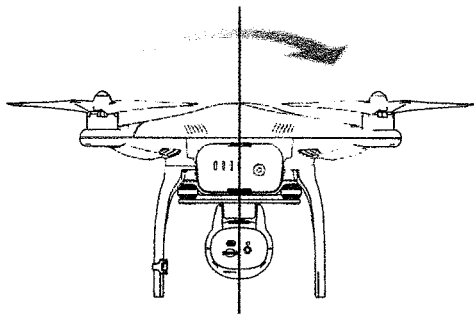

- 2** In a hover, starting with the battery pointed at yourself, rotate 360 degrees counter-clockwise.

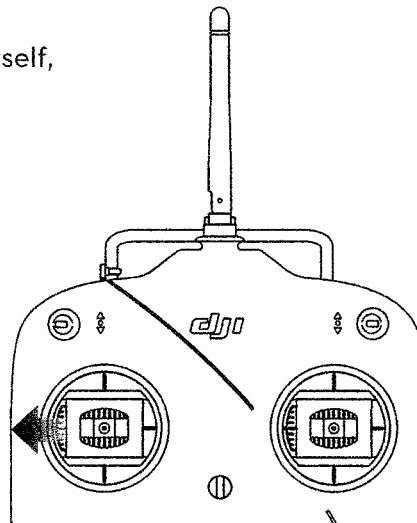
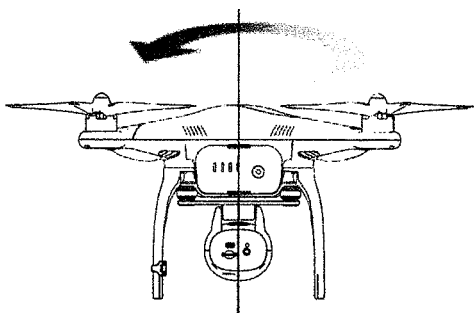

- 3** Starting with the battery pointed at yourself, go into a hover. Then rotate the Phantom 90 degrees facing left, and fly a 4 point square box formation going clockwise. Be sure to be in control and stop and hover in place at each point before proceeding to the next point.

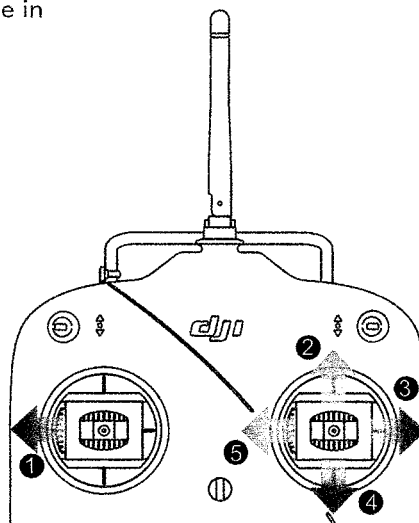
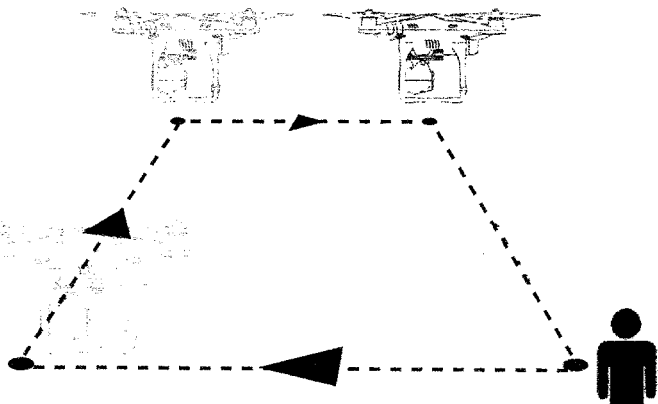

Skilled Flight Maneuvers (★★★)

- 4** Starting with the battery pointed at yourself, go into a hover. Then rotate the Phantom 90 degrees facing right, and fly a 4 point square box formation going counter-clockwise. Be sure to be in control and stop and hover in place at each point before proceeding to the next point.

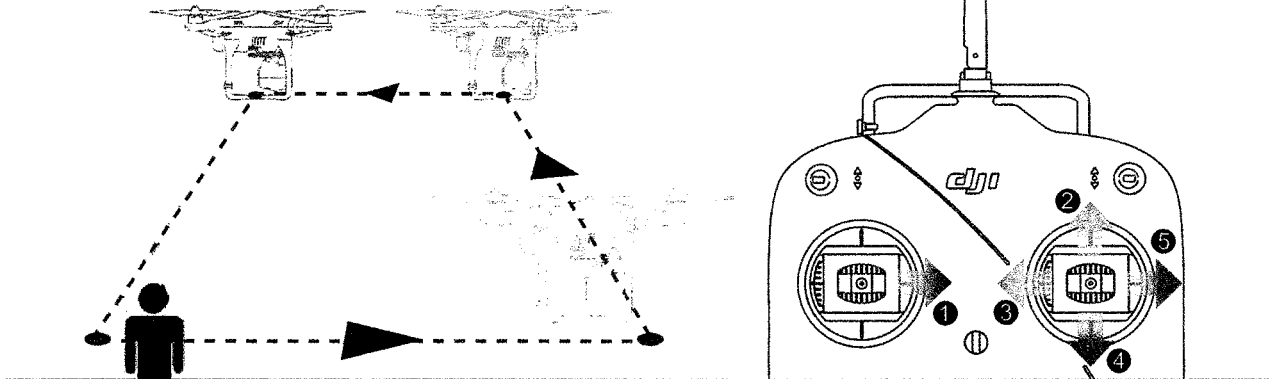

- 5** With the battery pointed at yourself, fly a circle. Try to keep the altitude and also the circle as uniform as possible.

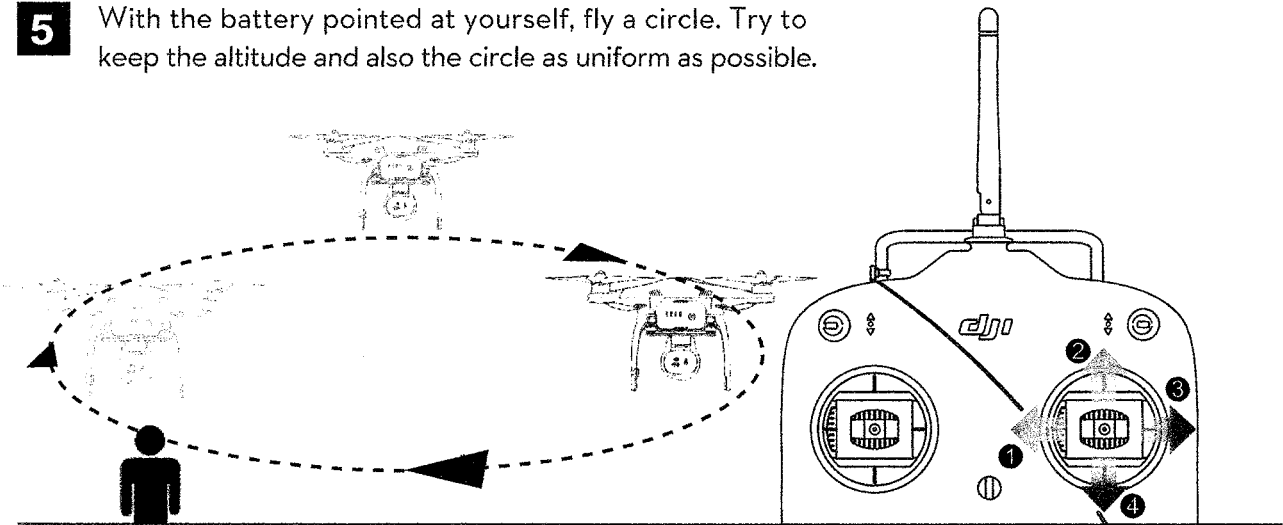

- 6** Hover with the camera pointed at yourself and try to keep the Phantom in one place.

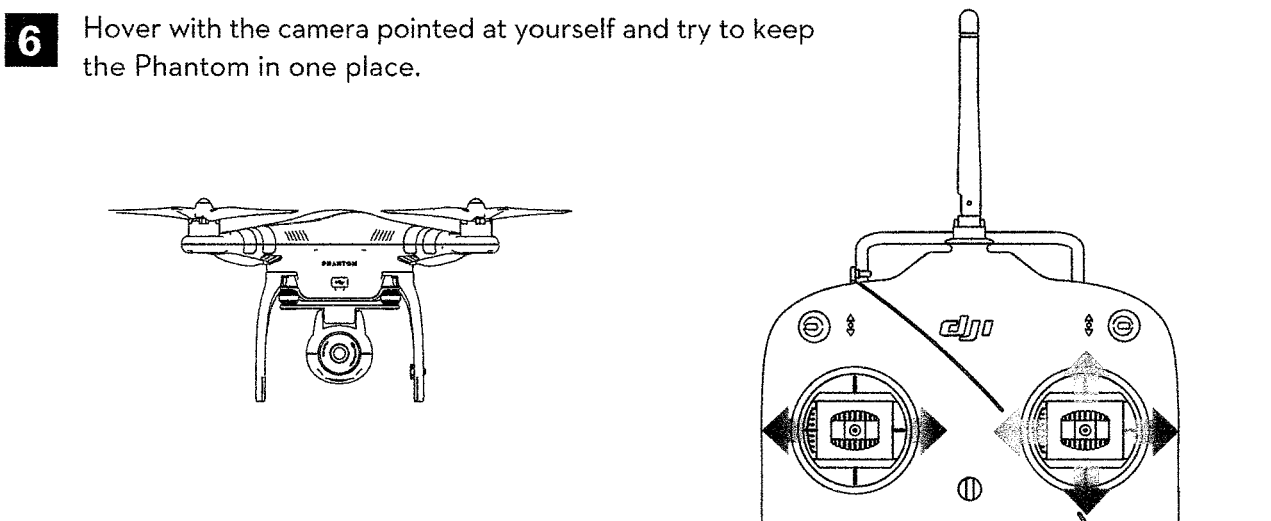

Advanced Flight Maneuvers (★★★)

- 1** Fly a circle and keep the camera pointed towards you. Be sure to keep the altitude the same and the circle as uniform as possible.

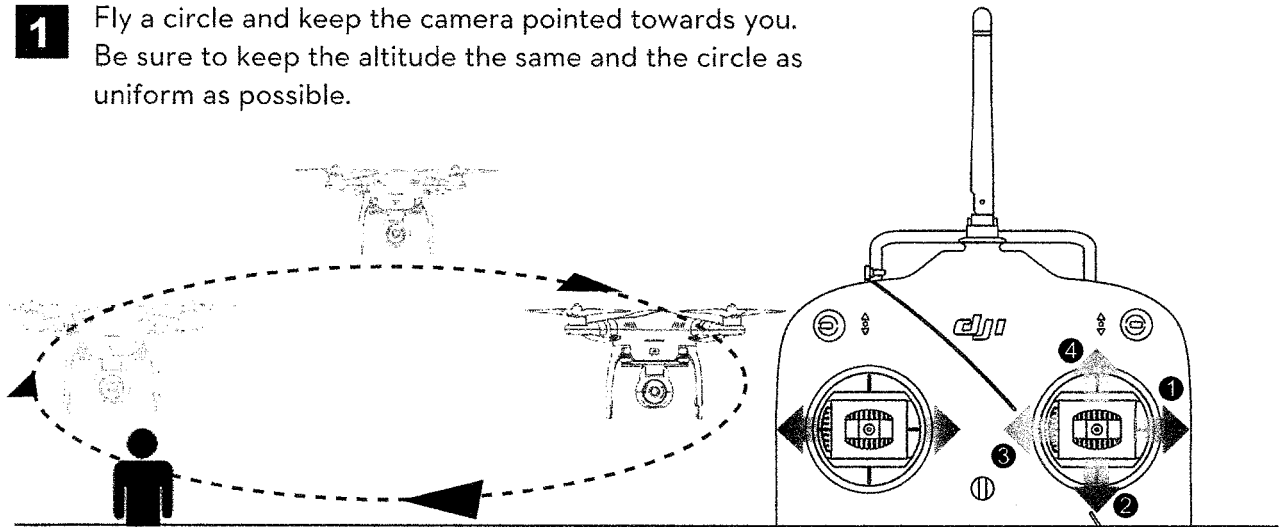

- 2** Fly a 4 point square box clockwise while keeping the camera facing in your direction.

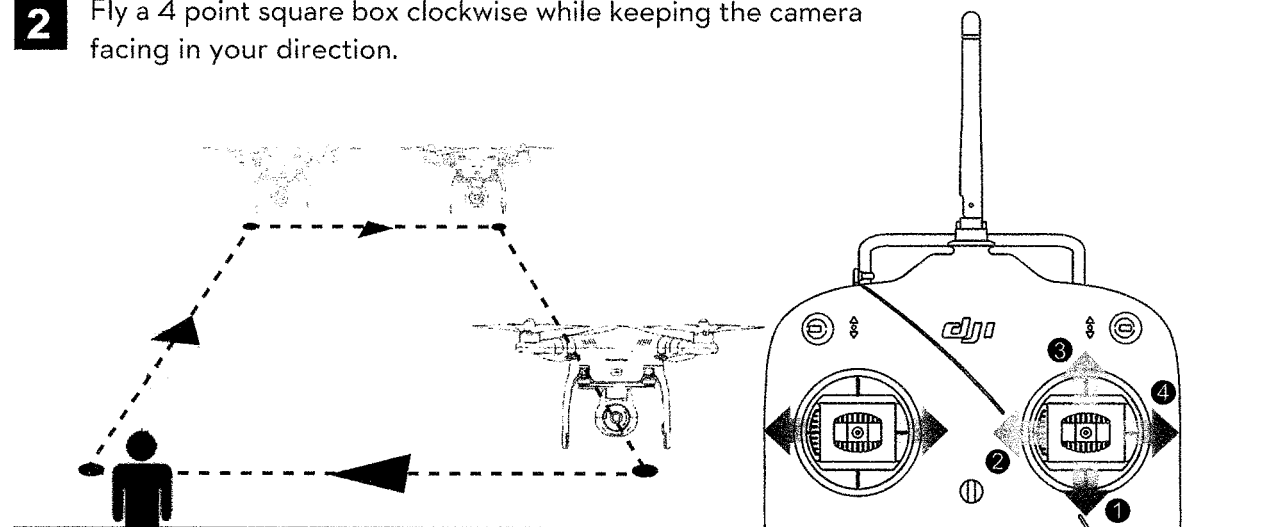

- 3** Fly a 4 point square box counter-clockwise while keeping the camera facing in your direction.

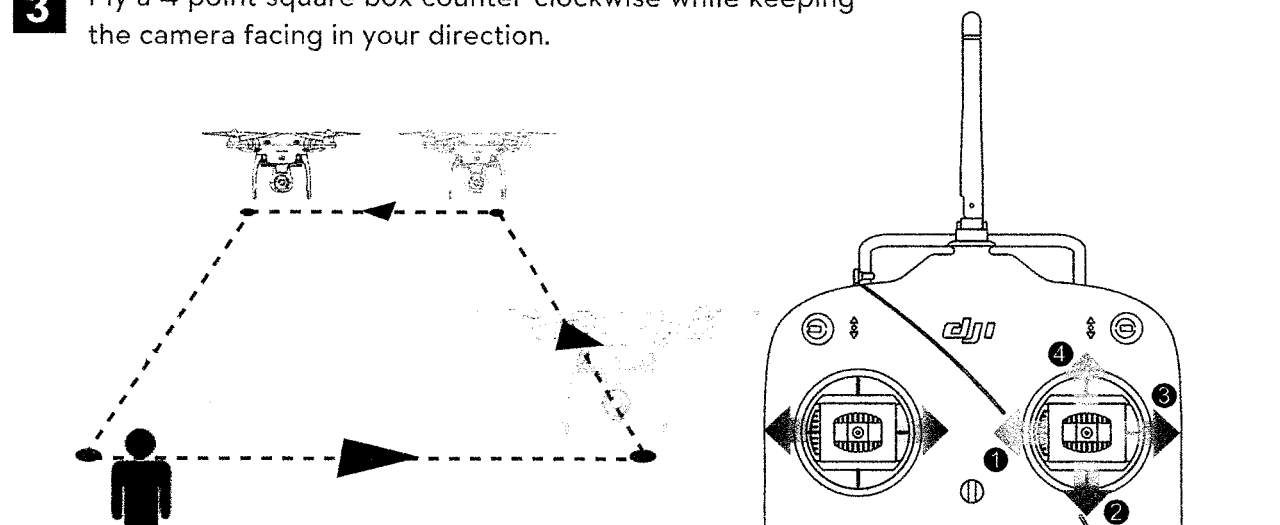

Advanced Flight Maneuvers (★ ★ ★)

- 4** Fly a 4 point square box clockwise and rotate the phantom in the direction of travel.

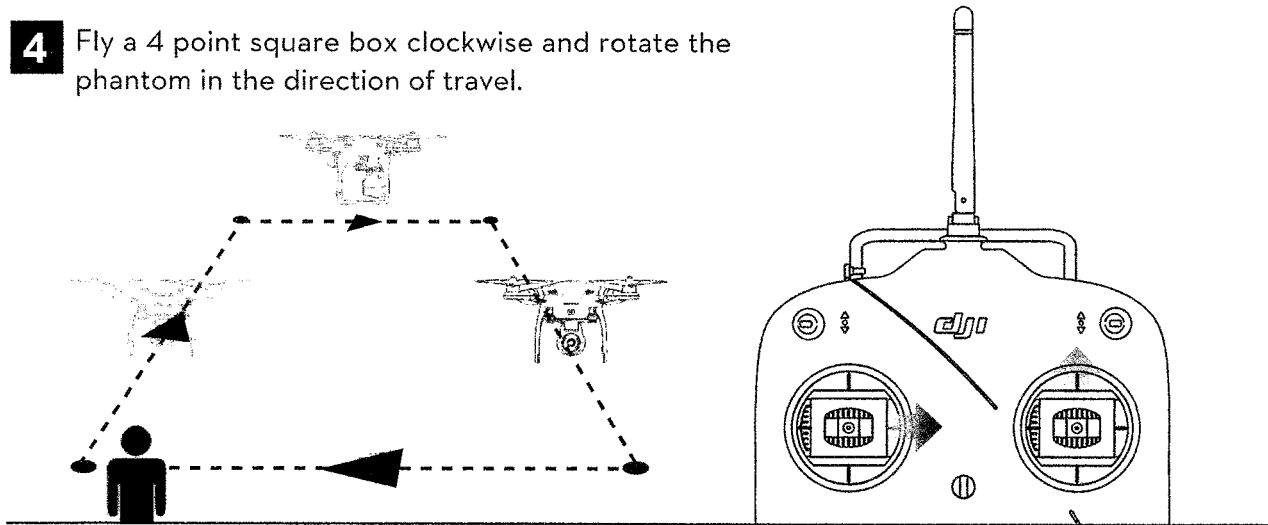

- 5** Fly a circle counter-clockwise and keep the camera pointed in the direction of travel. Be sure to keep the altitude the same and the circle as uniform as possible.

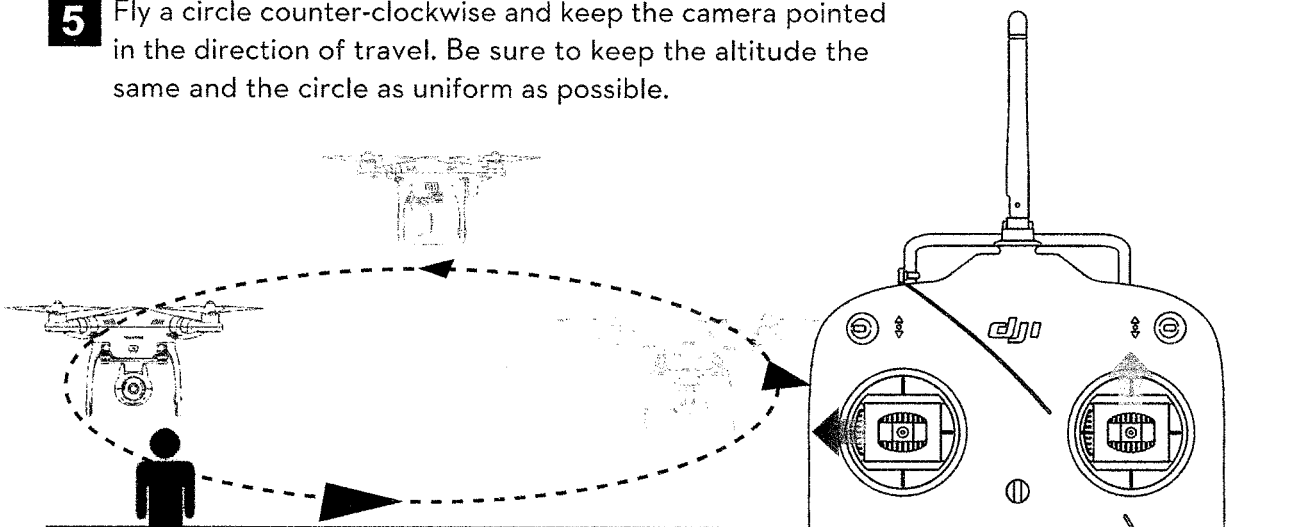

- 6** Fly a circle counter-clockwise with the camera pointed at the center of the circle. Be sure to keep the altitude the same and the circle as uniform as possible.

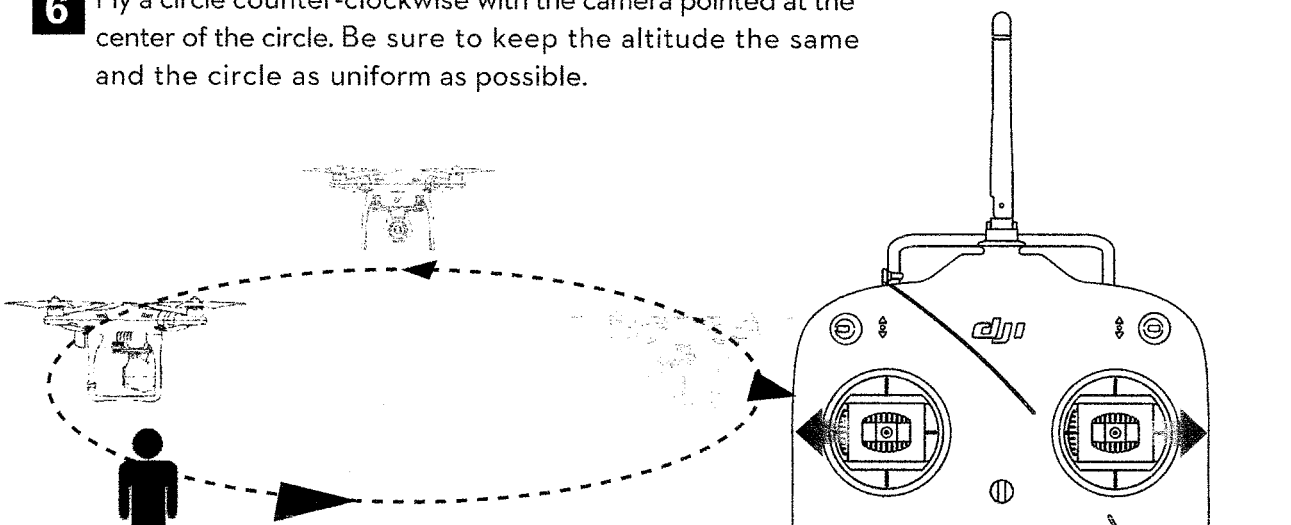

Advanced Flight Maneuvers (★ ★ ★)

- 7** Fly a figure 8 without rotating the Phantom. Be sure to keep the altitude the same and the circle as uniform as possible.

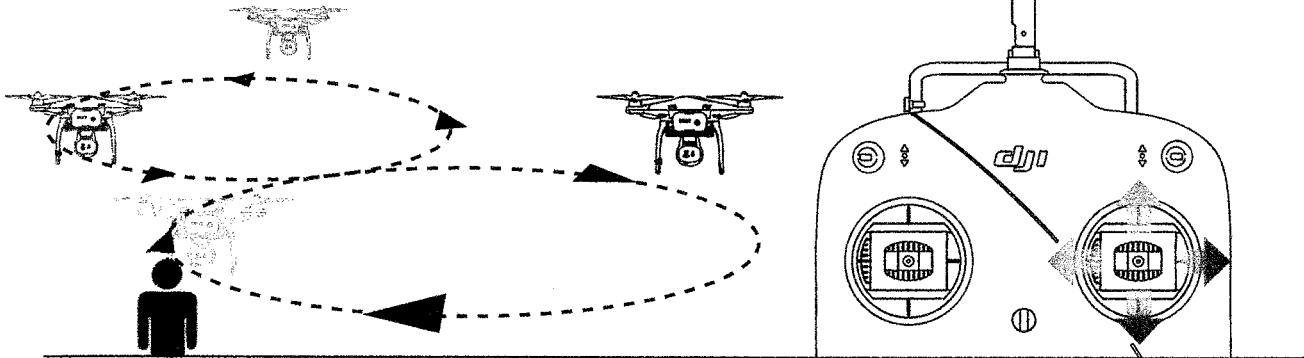

- 8** Fly a Figure 8 with the camera of the Phantom pointed in the direction of travel. Be sure to keep the altitude the same and the circle as uniform as possible.

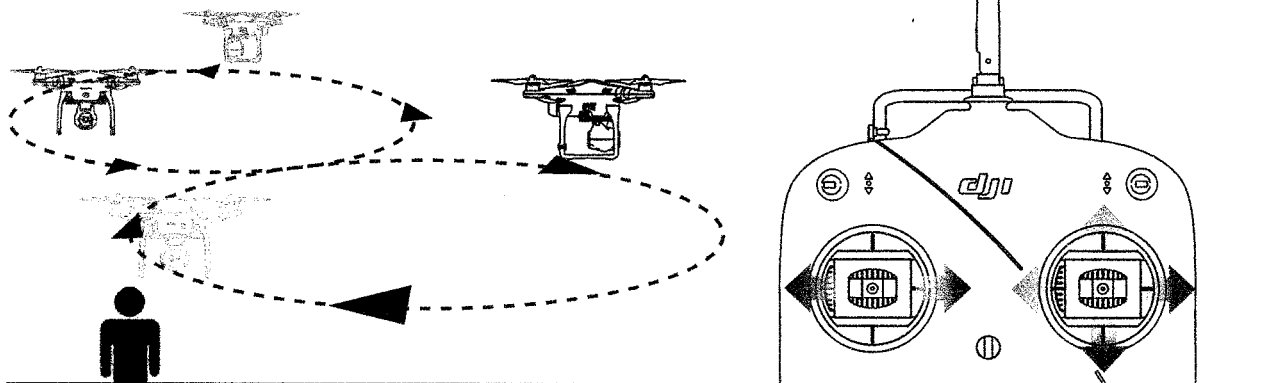

- 9** Fly Figure 8 patterns while experimenting with different orientations. For example, camera always pointed in a given direction or opposite/left/right the direction of travel, etc. Be sure to keep the altitude the same and the circle as uniform as possible.

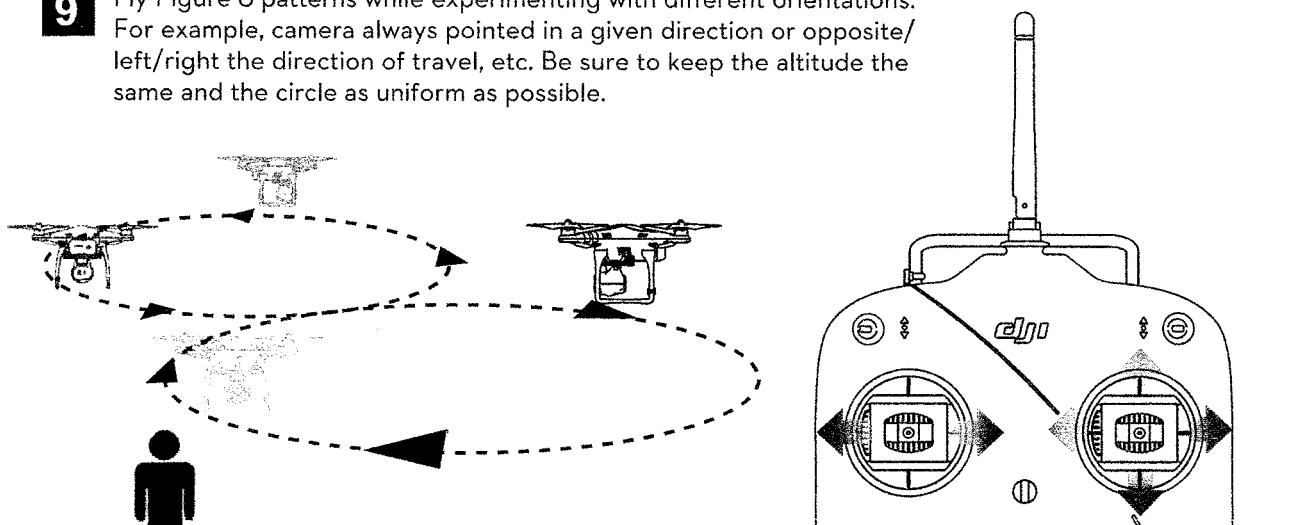

Emergency Situations

1 Return Home & Land Mode

Be sure you are in a large open area. Before you take off, make sure you have a good GPS lock by ensuring your LED indicators are flashing Green. Fly the Phantom at least 50ft away from your take off point. Turn off the Remote Controller. The Phantom will enter it's failsafe Return-To-Home Mode. Let the Phantom finish it's routine and land itself within 2 meters of the take off point.

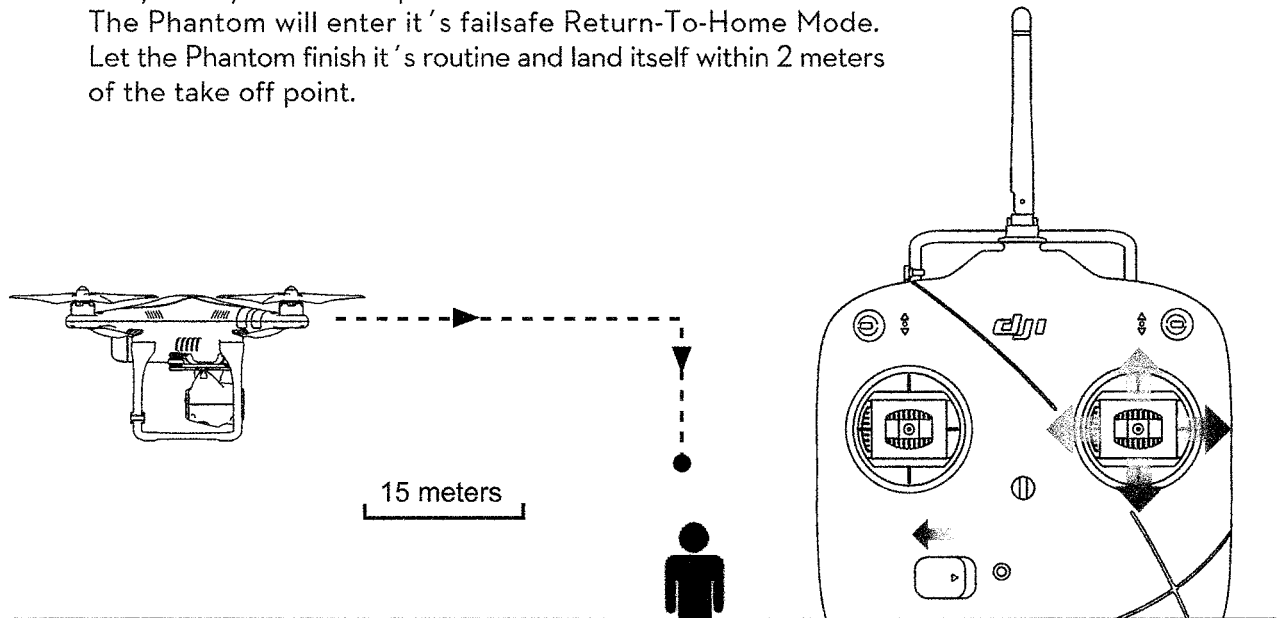

2 Intercepting Return Home & Land Mode

Be sure you are in a large open area. Before you take off, make sure you have a good GPS lock by ensuring your LED indicators are flashing Green. Fly the Phantom 50ft away from your take off point. Turn off the Remote Controller. The Phantom will enter it's failsafe Return-To-Home Mode. When the Phantom is returning home, you can intercept RTH Mode by switching the SI Switch from the top position to the middle or lower position, then continue flying the Phantom.

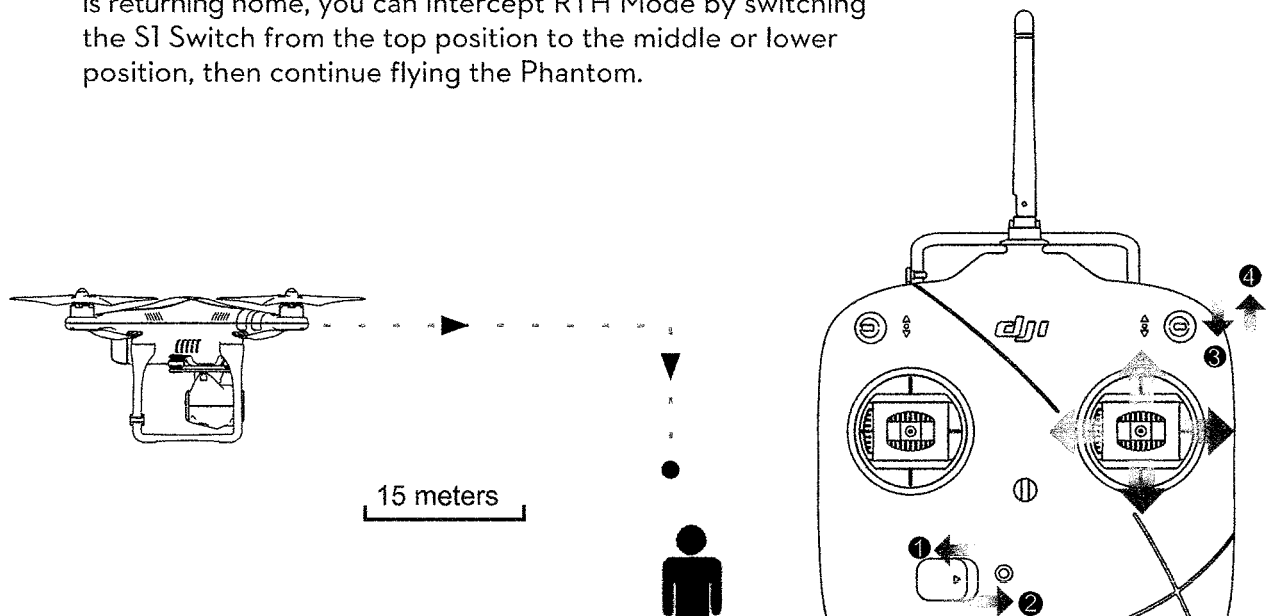

www.dji.com

Handwritten text, possibly a name or title.

Handwritten text, possibly a date or location.

Handwritten text, possibly a title or heading.

Handwritten text, possibly a name or title.

Handwritten text, possibly a name or title.

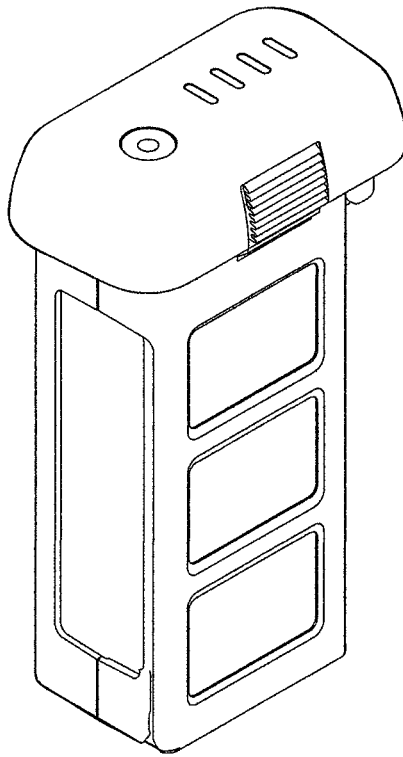

Small handwritten text or signature at the bottom left.

NOTICE

All instructions and other collateral documents are subject to change at the sole discretion of SZ DJI TECHNOLOGY CO., LTD. For up-to-date product information, visit <http://www.dji.com> and click on the product page for this product.

Glossary

The following terms are used throughout the product literature to indicate various levels of potential harm when operating this product:

NOTICE NOTICE: Procedures, which if not properly followed, create a possibility of physical property damage AND a little or no possibility of injury.

CAUTION CAUTION: Procedures, which if not properly followed, create the probability of physical property damage AND a possibility of serious injury.

WARNING WARNING: Procedures, which if not properly followed, create the probability of property damage, collateral damage, and serious injury OR create a high probability of superficial injury.



WARNING

Read the ENTIRE Phantom 3 user manual to become familiar with the features of this product before operating. Failure to operate the

product correctly can result in damage to the product or personal property and cause serious injury.

This is a sophisticated product. It must be operated with caution and common sense and requires some basic mechanical ability. Failure to operate this product in a safe and responsible manner could result in injury or damage to the product or other property. This product is not intended for use by children without direct adult supervision. Do not use with incompatible components or alter this product in any way outside of the documents provided by SZ DJI TECHNOLOGY CO., LTD. These Safety Guidelines contain instructions for safety, operation and maintenance. It is essential to read and follow all of the instructions and warnings in the Phantom 3 user manual, prior to assembly, setup or use, in order to operate the product correctly and avoid damage or serious injury.

Intelligent Flight Battery Safety Guidelines



WARNING

To avoid fire, serious injury, and property damage, observe the following safety guidelines when using, charging, or storing your batteries.

Battery Use

- 1) **Do NOT allow the batteries to come into contact with any kind of liquid. Do NOT leave batteries out in the rain or near a source of moisture. Do NOT drop the battery into water. If the inside of the battery comes into contact with water, chemical decomposition may occur, potentially resulting in the battery catching on fire, and may even lead to an explosion.**
- 2) **Never use non-DJI batteries. Go to www.dji.com to purchase new batteries. DJI takes no responsibility for any damage caused by non-DJI batteries.**
- 3) **Never use or charge swollen, leaky, or damaged batteries. If your batteries are abnormal, contact DJI or a DJI authorized dealer for further assistance.**
- 4) **Never install or remove the battery from the aircraft when it is turned on. Do NOT insert or remove batteries if the plastic cover has been torn or compromised in any way.**
- 5) **The battery should be used in temperatures from -10°C to 40°C. Use of the battery in environments above 50°C can lead to a fire or explosion. Use of battery below -10°C can lead to permanent damage.**

- 6) Do NOT use the battery in strong electrostatic or electromagnetic environments. Otherwise, the battery control board may malfunction and cause a serious accident during flight.
- 7) Never disassemble or pierce the battery in any way or the battery may leak, catch fire, or explode.
- 8) Electrolytes in the battery are highly corrosive. If any electrolytes make contact with your skin or eyes, immediately wash the affected area with fresh running water for at least 15 minutes, and then see a doctor immediately.
- 9) Check the condition of the battery if it falls out of the aircraft. Make sure the battery is NOT damaged or leaking before putting it back into the aircraft.
- 10) If the battery falls into water with the aircraft during flight, take it out immediately and put it in a safe and open area. Maintain a safe distance from the battery until it is completely dry. Never use the battery again, and dispose of the battery properly as described in the Battery Disposal section below. Do NOT heat batteries. Put out any battery fire using sand or a dry powder fire extinguisher. Never use water to put out a battery fire.
- 11) Do NOT put batteries in a microwave oven or in a pressurized container.
- 12) Do NOT place loose battery cells on any conductive surface, such as a metal table.
- 13) Do NOT put the loose cells in a pocket, bag or drawer where they may short-circuit against other items or where the battery terminals could be pressed against each other.
- 14) Do NOT drop or strike batteries. Do NOT place heavy objects on the batteries or charger. Avoid dropping batteries.
- 15) Clean battery terminals with a clean, dry cloth.

Battery Charging

- 1) Do NOT attach the batteries to wall outlets or car charger sockets directly, and always use a DJI approved adapter. DJI takes no responsibility if the battery is charged using a non-DJI charger. Never leave the battery unattended during charging. Do NOT charge the battery near flammable materials or on flammable surfaces such as carpet or wood. Do NOT charge battery immediately after flight, because the battery temperature may be too high. Do NOT charge the battery until it cools down to near room temperature. Charging the battery outside of the temperature range of 0°C-40°C may lead to leakage, overheating, or battery damage.
- 2) Disconnect the charger when not in use. Examine the charger regularly for damage to the cord, plug, enclosure, or other parts. Do NOT clean the charger with denatured alcohol or other flammable solvents. Never use a damaged charger.

Battery Storage

- 1) Keep batteries out of the reach of children and pets.
- 2) Do NOT leave the battery near heat sources such as a furnace or heater. Do NOT leave the batteries inside of a vehicle on hot days. The ideal storage temperature is 22°C-28°C.
- 3) Keep the battery dry. Never drop the battery into water.
- 4) Do NOT drop, strike, impale, or manually short-circuit the battery.
- 5) Keep the battery away from metal objects such as glasses, watches, jewelry, and hairpins.

Battery Disposal

- 1) Dispose of the battery in specific recycling boxes only after a complete discharge. Do NOT place the battery in regular trash containers. Strictly follow your local regulations regarding the disposal and recycling of batteries.

Battery Maintenance

- 1) Never use the battery when the temperature is too high or too low.
- 2) Never store the battery in environments with a temperature higher than 60°C.

Travel Notice

- 1) Before carrying the Intelligent Flight Battery on an airline flight, it must first be fully discharged. This can be done by using your aircraft until the battery is depleted. Only discharge the battery in a fireproof location.

NOTICE

Battery Use

- 1) Make sure the batteries are fully charged before each flight.
- 2) It is recommended that you do NOT charge the Intelligent Flight Battery and remote controller at the same time.
- 3) Land the aircraft immediately when the low battery level warning activates in the DJI Pilot app.

Battery Charging

- 1) Charge and discharge the battery completely once every 20 charge/discharge cycles. Discharge the battery until there is 8% remaining power or until it can no longer be turned on, then recharge it to the maximum capacity. This power cycling procedure will optimize battery life.
- 2) The Intelligent Flight Battery is designed to stop charging when it is full. However it is a good practice to monitor the charging progress and disconnect the batteries when fully charged.

Battery Storage

- 1) Discharge the battery to 30%-50% if it will NOT be used for 7 days or more. This can greatly extend the battery life.
- 2) The battery automatically discharges to below 65% when it is idle for more than 10 days to prevent it from swelling. It takes approximately 2 days to discharge the battery to 65%. It is normal that you may feel moderate heat emitting from the battery during the discharge process. Set the discharging thresholds in the DJI Pilot app.
- 3) The battery will enter hibernation mode if depleted and stored for a long period. When in hibernation mode, if you try to power on the battery, the battery power LED will show a solid red light and the battery level LEDs will all be off. You cannot manually turn off the battery power LED in this state. Leave the battery unattended for 5 minutes, and then the light will turn off. Recharge the battery to bring it out of hibernation.
- 4) Remove batteries from the aircraft when stored for an extended period.

Battery Disposal

- 1) If the power on/off button on the Intelligent Flight Battery is disabled and the battery cannot be fully discharged, please contact a professional battery disposal/recycling agent for further assistance.

Battery Maintenance

- 1) Never over-discharge, as this may lead to battery cell damage.
- 2) Battery life may be reduced if not used for a long time.

Travel Notice

- 1) Store Intelligent Flight Batteries in a ventilated location.

This content is subject to change.

Download the latest version from
www.dji.com/support



If you have any questions about this document, please contact DJI by sending a message to DocSupport@dji.com.