



Federal Aviation Administration
Alaskan Region

Capstone Program Management Office
801 B Street, Suite 500
Anchorage, Alaska 99501

Capstone Program Plan

DRAFT Version 3.0
12 June 2001



PREAMBLE

This document is designed as an umbrella program plan for the Federal Aviation Administration (FAA) Alaskan Region Capstone Program. The term umbrella, as it is used here, means the contents are intended to create high level objectives from which detailed work plans can be developed and accomplished. Each organization that accepts tasking under a particular objective or element takes with it the responsibility for developing a work plan, generating procedures for participants to use their element, and for recording and reporting the progress made toward validation. To accommodate future developments facilitated by the Capstone Program efforts, the number and the date of each successive program plan version is printed on the cover.

This Capstone Program Plan version 3.0 is complimentary to Versions 1.0 and 2.0. These previous versions established the initial Capstone avionics and ground infrastructure. Version 3.0 documents the activities supporting the infrastructure in the Bethel/Yukon-Kuskokwim delta area, planning for expansion to Juneau/Southeast Alaska, and establishing ties to future implementation work, with the main focus on FY 2001.

EXECUTIVE SUMMARY

The Capstone Program accelerates efforts to improve aviation safety and efficiency through a multi-year introduction of current and emerging concepts and technologies. According to information published by the National Institute for Occupational Safety and Health, accident rates in Alaska are elevated up to 400 percent above the national average. The absence of services, such as usable IFR infrastructure, makes Alaska the ideal location to evaluate key new communications, navigation, and surveillance (CNS) technologies. These technologies can better allow pilots to deal with navigation, terrain, traffic, and weather hazards. Concepts and recommendations contained in reports from the RTCA (formerly Radio Technical Commission on Aeronautics) Inc., the National Transportation Safety Board (NTSB), and the Alaskan aviation community play a key role as these organizations partner with the FAA to identify and mitigate risks associated with solving safety problems and with a transition toward modernization of the National Airspace System (NAS). The name “Capstone” is derived from the program’s effect of drawing and holding together these concepts and recommendations.

Current Capstone planning is focused on two regions of Alaska: Capstone Phase I addresses the Bethel/Yukon-Kuskokwim (Y-K) delta area and Capstone Phase II addresses the Juneau/Southeast (SE) Alaska area. Phase I planning in the Bethel/Y-K delta area includes the installation of government-furnished Global Positioning System (GPS) driven avionics suites in up to 200 commercial aircraft serving the Bethel/Y-K delta area and supporting ground based infrastructure. Compatible data link transceivers installed at strategically located ground sites were designed to facilitate Air Traffic Control, Flight Monitoring, and Flight Information Services. This planning “bundled” capabilities/technologies such as Automatic Dependent Surveillance-Broadcast (ADS-B), Automated Weather Observing Systems (AWOS), and GPS approaches to improve safety and access to remote locations in the Bethel/Y-K delta.

Aircraft chosen to participate in Capstone Phase I have been equipped with:

- An Instrument Flight Rules (IFR)-certified GPS receiver for enhanced navigation capabilities.
- A Universal Access Transceiver (UAT) data link radio to provide the pilot with current decision making information. These services include a capability to “see and avoid” other ADS-B equipped aircraft; Traffic Information Services-Broadcast (TIS-B) to display additional radar targets on an aircraft multi-function display (MFD); and Flight Information Services (FIS) to transmit graphical weather maps including Next Generation Weather Radar (NEXRAD) and textual weather information reports in the form of Meteorological Aviation Reports (METARs) and Terminal Area Forecasts (TAFs). Additional services available through ADS-B include providing surveillance information that air traffic controllers can use for providing air traffic service and information that aircraft operators/dispatchers can use for aircraft monitoring.
- A panel mounted multi-function color display to present information from the above components and to present a terrain advisory database to help avoid collisions with terrain.

During Phase II, which begins in 2001, Capstone will incorporate technologies matured in the Bethel/Y-K area, build on lessons learned, and explore expansion of the use of other risk mitigating technologies to reduce accidents and fatalities in the Southeast area of Alaska. In order to ensure each new component slated for development dovetails with industry safety needs, representatives from Capstone have met with local industry representatives to establish goals and objectives for future work in Southeast Alaska. In addition to the technologies adopted from Bethel/Y-K delta, additional technologies will be evaluated to provide a “more useable IFR infrastructure.”

Capstone provides program-funding wedges for future year implementation of technologies that provide the anticipated safety benefits, so that there is no gap between the Capstone technology demonstrations, the continued operation at the demonstration locations, and further implementation. While the Capstone Program Office demonstrates and documents the operational benefits that are to be gained, planning for statewide implementation will be part of the Alaskan Regions approach to improve safety and increase access to other areas of Alaska. All of the technologies that Capstone provides for statewide implementation will be developed so that they can also be deployed throughout the NAS.

Capstone is working with the Safe Flight 21 Program Office at FAA Headquarters to document the operational benefits of these systems, the impact on safety, and the cost benefit of equipage. Coordination is important between the Safe Flight 21 technology evaluations conducted with the Cargo Airline Association and the Capstone demonstrations conducted with the Alaskan aviation industry.

The Capstone Program Office reports to the Alaskan Regional Administrator and serves to plan and coordinate implementation of safety products into the aviation system. Oversight of the program is provided by a Management Review Board, made up of FAA Senior Executives and managers from participating organizations providing periodic review of the Capstone Program.

TABLE OF CONTENTS

1.	INTRODUCTION.....	1
1.1	Background.....	1
1.2	Purpose.....	2
1.3	Objectives.....	2
1.3.1	Safety	2
1.3.2	Capacity and Efficiency	2
1.3.3	Information for Decision-Makers.....	3
1.4	Strategy	3
1.5	Capstone Capabilities and Status	3
1.5.1	FY 1999	3
1.5.2	FY 2000	4
1.5.3	FY 2001	4
2	CONCEPT OF OPERATIONS	5
2.1	Bethel/Y-K Delta	7
2.2	Juneau/SE Alaska.....	7
3	ARCHITECTURE	8
3.1	Capstone Ground System	Error! Bookmark not defined.
3.1.1	ZAN Operational Infrastructure	Error! Bookmark not defined.
3.1.2	Operational Test Support	Error! Bookmark not defined.
3.2	Capstone Avionics Phase I.....	13
3.3	AWOS III.....	14
3.4	Consideration for Capstone Phase II in Southeast Alaska.....	14
4	DEMONSTRATION ACTIVITIES	15
4.1	Phase I Bethel/Yukon-Kuskokwim (Y-K) Delta.....	16
4.1.1	Status.....	16
4.1.2	Continuing Activities	18
4.2	Phase II Juneau/Southeast (SE) Alaska	21
4.2.1	Status.....	22
4.2.2	Continuing Activities	24
4.3	Program Activities.....	24
4.3.1	Test Plan Activities	24
4.3.2	Operational Evaluation and Safety Study	25
4.3.3	Cost Benefit Analysis.....	25
4.3.4	Operational System Safety Review.....	26
4.3.5	ATS Readiness Review and IOT&E Issues	26
4.3.6	Lessons Learned Documentation	26
5	TRANSITION TO NAS IMPLEMENTATION	26
5.1	Statewide	26
5.2	National	27
6	CAPSTONE PROGRAM MANAGEMENT.....	27
6.1	Capstone Organization	27

6.1.1 Capstone Management Review Board 28
6.1.2 Capstone Program Office (CPO) 28
6.1.3 Capstone Program Office Staffing 30
6.1.4 Alaska Aviation Industry Capstone Coordination..... 31

ATTACHMENT 1 CAPSTONE REQUIREMENTS AND COSTS (FY'99 - '01)..... 1

**ATTACHMENT 2, COST AND SCHEDULE FOR STATEWIDE
IMPLEMENTATION F&E (FY'02 - '05)..... 1**

APPENDIX A ACRONYMS..... 1

**APPENDIX B BETHEL/Y-K DELTA IMPROVED SPECIAL VFR OPERATIONS
CONCEPT 1**

**APPENDIX C CAPSTONE CONCEPT OF OPERATIONS FOR SOUTHEAST
ALASKA 1**

**APPENDIX D ACTION PLAN FOR CAPSTONE PHASE I - BETHEL/Y-K
DELTA 1**

**APPENDIX E ACTION PLAN FOR CAPSTONE PHASE II – JUNEAU/SE
ALASKA 1**

1. INTRODUCTION

The first priority of Capstone is to improve aviation system safety in Alaska through the introduction of new communications, navigation, and surveillance (CNS) technologies. Capstone is also using these same technologies to improve aviation system capacity and efficiency. Foremost, these technologies enable pilots to deal with terrain, traffic conflict and weather hazards. They also allow dispatchers/operators better means to monitor their aircraft, and air traffic controllers expanded surveillance coverage to provide Air Traffic Control (ATC) services.

Secondly, Capstone provides answers to technical, operational, and cost/benefit questions that enable the FAA and industry decision-makers to make future CNS technology implementation choices. Some of these questions were raised in a RTCA document on Free Flight operational enhancements.¹ Capstone addresses many of these areas and the overall Safe Flight 21 Program addresses the remainder through additional work with the aviation industry. Capstone provides an improved aviation system and an infrastructure from which to gather data necessary to make better decisions on implementing the future National Airspace System (NAS) architecture.

Capstone participation with the Alaskan aviation industry is vital to the successful outcome of the program. Industry “buy-in” connects everyone to the goals and objectives of Capstone and ensures support. This involvement helped establish the avionics and ground system equipment requirements and drives the need to demonstrate early tangible progress in improving aviation safety and efficiency.

1.1 Background

Alaska experiences an average loss of 45 lives each year from aircraft accidents, almost five times greater than similar areas in the continental United States. The National Transportation Safety Board (NTSB) identified a number of improvements in Alaska’s aviation system that could reduce fatal accidents in the various sectors of Alaska.² A FAA, ASD-430, Operations and Research Analysis Branch study concluded that approximately 38 percent of these fatal accidents could be avoided by providing the pilot with an improved situational awareness of terrain, traffic, and weather.³ For the remaining percentage of accidents the intent is to provide surveillance capabilities that can improve search and rescue efforts in the hopes of saving additional lives.

¹ Joint Government/Industry Roadmap for Free Flight Operational Enhancements, August 1998.

² Safety Study NTSB/SS-95/03, Aviation Safety in Alaska, November 1995.

³ Economic Justification for FAA’s Flight 2000 Program, September 23, 1997.

1.2 Purpose

Capstone provides the avionics and ground system infrastructure that will lead to improved aviation safety in Alaska. It also provides the launching platform for validation of many essential elements needed to move toward the Free Flight concept and NAS operational evolution. Introduction of the future CNS components of the NAS architecture allows an assessment of operational capabilities and mitigation of monetary and safety risk exposure. The technology fielded under Capstone may be modified during national implementation and need to be upgraded or replaced.

1.3 Objectives

Capstone's principle objective is to improve aviation safety in Alaska. Equipage of aircraft and ground sites in Capstone demonstration areas also provides an excellent opportunity to improve aviation system capacity and efficiency, and to work with the Safe Flight 21 office to evaluate CNS technology. Specific objectives of Capstone Phase I are listed below and are being measured against the "Air Safety in Southwest Alaska - Capstone Baseline Safety Report" produced by the University of Alaska. Specific objectives for Capstone Phase II will be similar, and are being developed in coordination with a new Capstone baseline safety report for Southeast Alaska.

1.3.1 Safety

- Reduce the fatal accident rate (on a per-flight-hour basis) due to en route and approach navigational errors in marginal visibility situations by 25% in the equipped aircraft within one year after installation of equipment and new low altitude airspace design and procedures are in place.
- Reduce the fatal accident rate from mid-air collisions en route between the airports involved in Capstone and in the vicinity of Bethel by 25%.
- Reduce the fatality rate due to search and rescue failures for equipped aircraft in the Bethel area.

1.3.2 Capacity and Efficiency

- Reduce the number of flights cancelled after departure due to inadequate destination weather reporting at airports equipped with new automated weather sources by 10% within one year.
- Reduce flight delays due to weather by 5% within one year for flights into Capstone airports.
- Reduce operators' cost for fuel wasted due to adverse weather situations on equipped aircraft in the Bethel area within one year.

1.3.3 Information for Decision-Makers

Together with the Safe Flight 21 office, Capstone can provide experience and data to support technical and operational CNS evaluation. Capstone specifically provides the opportunity to look at technologies in non-radar and radar areas, with mountainous and non-mountainous terrain, at low altitudes, in extremely low temperature and severe weather conditions, and on a variety of general aviation airframes. Cost benefit data, such as equipment installation costs and fuel savings achieved due to better in-flight information can also be developed.

1.4 Strategy

Capstone provides the avionics and ground system infrastructure that will lead to improved aviation safety, capacity, and efficiency in Alaska. Capstone also initiates a streamlined way of integrating activities needed to implement new technologies and a method of providing answers to technical, operational and cost/benefit questions. As these technologies are evaluated, approved, and certified for the various operational enhancements, the FAA will expand the ground infrastructure and pilots will be allowed to self-equip with compatible avionics. Capstone will provide operational demonstrations in phased areas, starting with the Phase I Bethel/Y-K delta and the Phase II Juneau/SE area. Each Phase may bring additional operational needs and therefore new technology requirements.

Capstone focuses on:

- Near term safety benefits,
- Technology,
- Capabilities/Requirements developed with industry,
- Activities to trigger self-equipage,
- Activities consistent with future NAS.

1.5 Capstone Capabilities and Status

An accident is made up of a chain of events, and Capstone takes a systematic approach to break that chain by bundling technologies and providing them to multiple segments of the aviation system (e.g., pilots, controllers, and dispatchers). Capstone provides an improved ground and air infrastructure that furnishes pilots with better information on the location and severity of hazardous weather; on proximity to terrain; on improved instrument approaches to small airports; and on traffic information for the reduction of mid-air collisions. Additionally, improved surveillance information to controllers assists in sequencing, separation, flight following, and search and rescue activities. This same surveillance information to the dispatchers/operators allows better company flight monitoring. The Capstone program provides answers to key questions based on real-time commercial flight operations.

1.5.1 FY 1999

During FY 1999, FAA purchased Capstone avionics suites for installation in small commercial service aircraft operating in the Bethel/Y-K delta area. The avionics suites

consisted of a GPS navigation unit, a multi-function display with moving map and terrain database, and ADS-B service via a Universal Access Transceiver (UAT) data link radio. Demonstration and certification activities were conducted throughout FY 1999, including an end-to-end demonstration in Bethel during August 1999. Planning and development continued for a network of Ground Broadcast Transceivers (GBT) ground stations to receive and forward aircraft ADS-B position reports to the Anchorage Air Route Traffic Control Center (ARTCC) for processing and display by the Micro-En Route Automated Radar Tracking System (MEARTS). Preparation of GPS non-precision approach procedures for ten village airports and installation of AWOS IIIs to support these first-time instrument approach procedures began. The University of Alaska was contracted to develop an independent safety analysis and a pilot training program for use of the Capstone avionics. Within the Alaskan Region, the Capstone Program continued modeling a transition to the future NAS architecture and serving as the focal point for unified planning, coordination, and development.

1.5.2 FY 2000

For FY 2000, the Capstone Program continued building its partnerships with the air carrier and avionics industries, the Safe Flight 21 Program, and other national program offices. Delivery of the avionics installation kits began in December 1999 and with certification of the avionics for supplemental Visual Flight Rules (VFR) use complete, delivery and installation of the avionics began in February 2000. Flight Information Service-Broadcast (FIS-B) upgrades were available summer 2000. In addition, work on certifying the avionics for ATC radar-like services neared completion. A major portion for this year's work was the certification and installation of the Capstone ground system and avionics architecture to provide radar-like services. Additional village airports were GPS-surveyed and furnished with first-time non-precision GPS approach procedures. Capstone continued to incorporate certain safety and "technology-driven" improvements recommended in the March 1995 NTSB Alaska Safety Study; for example, more AWOS facilities were installed and near real-time weather products such as NEXRAD graphical displays were disseminated via the Capstone FIS-B system to the pilot.

1.5.3 FY 2001

While the initial Capstone system improves the pilot's situational awareness in VFR, on 1 January 2001 Capstone began operational use of ADS-B to provide VFR and IFR radar-like services in airspace in and around Bethel, Alaska. This historic event marked the beginning of ATC use of ADS-B for separation, vectoring, and sequencing aircraft. FY 2001 activities will focus on completion of Phase I Capstone ground service area requirements in and around Bethel/Y-K delta. Non-precision approach procedures developed and already published will be supplemented with additional procedures at adjacent village airports within the Phase I area. Avionics will continue to be installed to ensure constant and consistent data collection during the validation period. MEARTS modifications will also aid the data collection and validation process as controllers provide key safety services through use of ADS-B. This also provides the opportunity to distribute ADS-B data for operator's to monitor the progress of their aircraft. Previous plans for a Bethel Air Traffic Control Tower (ATCT) display to increase controller situational awareness and improve Special VFR (SVFR) operations will be "revisited" during the validation phase.

Additional FY 2001 congressional funding was provided to begin a Capstone transition to Southeast (SE) Alaska as Phase II. This provides new challenges because of the vastly different operating conditions for this meteorologically diverse, mountainous, and maritime environment. The industry in SE Alaska has described their view of success in advancing safety as a "more useable IFR infrastructure," with focus on navigational capability for lower enroute altitudes, improved communications, weather information, surveillance, Controlled Flight into Terrain (CFIT) protection, and traffic awareness. As in earlier Capstone activities, emphasis remains on safety improvement, but with differing needs in SE Alaska, new questions relating to modernization need to be answered. In SE, Capstone will answer questions relating to certification and application of several new and integrated technologies, including those related to mixed equipage and ADS-B technology (including TIS-B). Phase II will demonstrate increased access to terrain constrained airspace where traditional navaids and radar are ineffective.

2 CONCEPT OF OPERATIONS

Under Capstone, the Alaskan Region serves as a real-world demonstration of CNS technologies, procedures, and certification techniques. Capstone uses avionics and a corresponding ground infrastructure that have passed testing, certification, and operational approval for safe introduction of systems into the existing Alaskan operational environment and the NAS. Capstone implements technology that has previously not been widely used by small aircraft, and focuses on operational benefits that can result by implementing avionics, ground systems, and operational procedures. Demonstration areas are determined in collaboration with the Alaskan aviation industry and various safety studies, such as NTSB reports. The area of initial focus was the Bethel/Y-K delta and now focus will expand into the Juneau/SE Alaska area.

While avionics and ground systems are being put in place, user groups and air traffic controllers will focus on concepts of operations and use. These concepts define the benefits that are anticipated and how those benefits will be provided through the use of these new systems.

The Capstone Program Office, in coordination with the Safe Flight 21 Program, reviewed various operational concepts and application description regarding ADS-B applications, FIS-B, and CFIT avoidance. Below is the list of Safe Flight 21 operational enhancements with a high level description as applied to Capstone. Note in some cases, Capstone is implementing the enhancement (or part thereof) differently than the original Safe Flight 21 operational concept. For more detail on the Safe Flight 21 operational enhancements see the Safe Flight 21 Master Plan⁴ and the Safe Flight 21 High-Level Concepts of Operations⁵.

⁴ Safe Flight 21 Master Plan Version 2.0, April 2000.

⁵ Safe Flight 21 Ops/Procedures Subgroup, High-Level Concept of Operations, 12 January 2001.

- **Weather and Other Information to the Cockpit.** This enhancement will use the data link to receive current and forecasted weather, weather-related information, and other information. The information will be displayed in text and graphics to the pilot.
- **Cost Effective CFIT Avoidance.** This enhancement increases the pilot's situational awareness by providing a cost/effective terrain and obstacle database and integrated display in the cockpit. With additional navigation equipment access can be increased to terrain constrained low altitude airspace.
- **Improved Terminal Operations in Low Visibility.** Defined differently from the Safe Flight 21 operational applications, Capstone is improving low visibility terminal operations by installing AWOS facilities and GPS approaches in remote village airports. With the use of ADS-B and corresponding procedures, SVFR operations may also be improved.
- **Enhanced See and Avoid.** This enhancement provides traffic information, electronically, to the cockpit using ADS-B, cockpit traffic displays, and TIS-B. This will enable the pilot to maintain situational awareness of surrounding traffic.
- **Enhanced En Route Air-to-Air Operations.** This enhancement will evaluate use of an on-board traffic/navigation display and ADS-B for flight path adjustments beyond visual range while pilots are operating VFR initially and IFR in the future.
- **Improved Surface Surveillance and Navigation for the Pilot.** This enhancement will be designed to allow pilots in the cockpit and the operators of equipped vehicles on the airport surface to “see” all the other traffic on a display with a moving map, resulting in safer and more efficient surface operations. Also, aircraft will be able to taxi using augmented GPS navigation and maps.
- **Enhanced Airport Surface Surveillance for the Controller.** This enhancement will equip the aircraft and ground vehicles in the airport movement area with ADS-B using augmented GPS-derived positions. The local and ground controllers in the tower will monitor the position and speeds of the traffic in the movement area.
- **ADS-B Surveillance in Non-Radar Airspace.** This enhancement will use ADS-B to provide additional surveillance coverage and fill gaps in today’s radar coverage. ATC, operators/dispatchers, and potentially the Automated Flight Service Stations (AFSS) will use this information.
- **ADS-B Surveillance in Radar Airspace.** Current automation is limited in providing benefits to users based on existing radar accuracy, update rate, and available information. This enhancement will integrate ADS-B data with radar

and ATC automation systems to improve capabilities and to determine if today's separation standards can be achieved or reduced.

2.1 Bethel/Y-K Delta

The Capstone Program Office facilitated working with the various FAA lines of business to bring ADS-B into operations as a source of surveillance information for use by Air Traffic Control. Work will continue on maturing this capability. The Alaskan Region Air Traffic Division (AAL-500) wrote a white paper (Appendix B) that outlines how this ADS-B information may be used to reduce delays associated with the management of the large number of special VFR aircraft mixed with IFR aircraft in the Bethel area, which have been a significant problem for many years. Meetings with the aviation industry have resulted in ideas that can effect positive change in the way air traffic is managed in this area. These changes can significantly improve the safety and efficiency of operations, saving the system users time and money in the process. This paper will be used by Capstone as a concept for improved operations in the Bethel/Y-K Delta area.

2.2 Juneau/SE Alaska

Capstone Program planning in SE Alaska is focused on an operational concept for a "more useable IFR infrastructure." This will include technologies such as ADS-B, Multilateration, augmented GPS Wide Area Augmentation System (WAAS), and a display of terrain data. Follow-on planning between the aircraft users and controllers will focus on several concepts of use to include:

- Enhancing communication, navigation, weather observations and airspace design to enable lower enroute and approach/departure routes;
- Providing aircraft position information for use by controllers to enhance VFR and IFR aircraft arrivals and departures;
- Developing the use of these systems to provide runway incursion information to pilots and controllers;
- Providing aircraft position information for use by aircraft operators and AFSS for search and rescue.

A team was formed made up of representatives from Juneau ATCT/National Air Traffic Controllers Association (NATCA), Anchorage ARTCC, Regional Air Traffic Division, Juneau AFSS, Alaska Airlines, Wings Alaska, Capstone Program Office/Flight Standards to create a document that captures the operational needs of Southeast Alaskan users. A scenario type operational concept was written that walks through how new technology will be employed in the cockpit and the interaction required with each service provider. This will be a guiding document for the Capstone activities in Southeast Alaska. See Appendix C.

3 ARCHITECTURE

The target high-level Capstone architecture is depicted in Figure 3-1 and described in three segments: A) Anchorage ARTCC, B) Remote Site, and C) Airborne Configuration. As new capabilities are explored and matured in SE Alaska, this architecture will evolve to include those elements. Architecture implications for SE Alaska are discussed at the end of this section. The weather observation equipment (AWOS III) is not depicted in this architecture figure given it is a stand-alone system, but is explained later in this section.

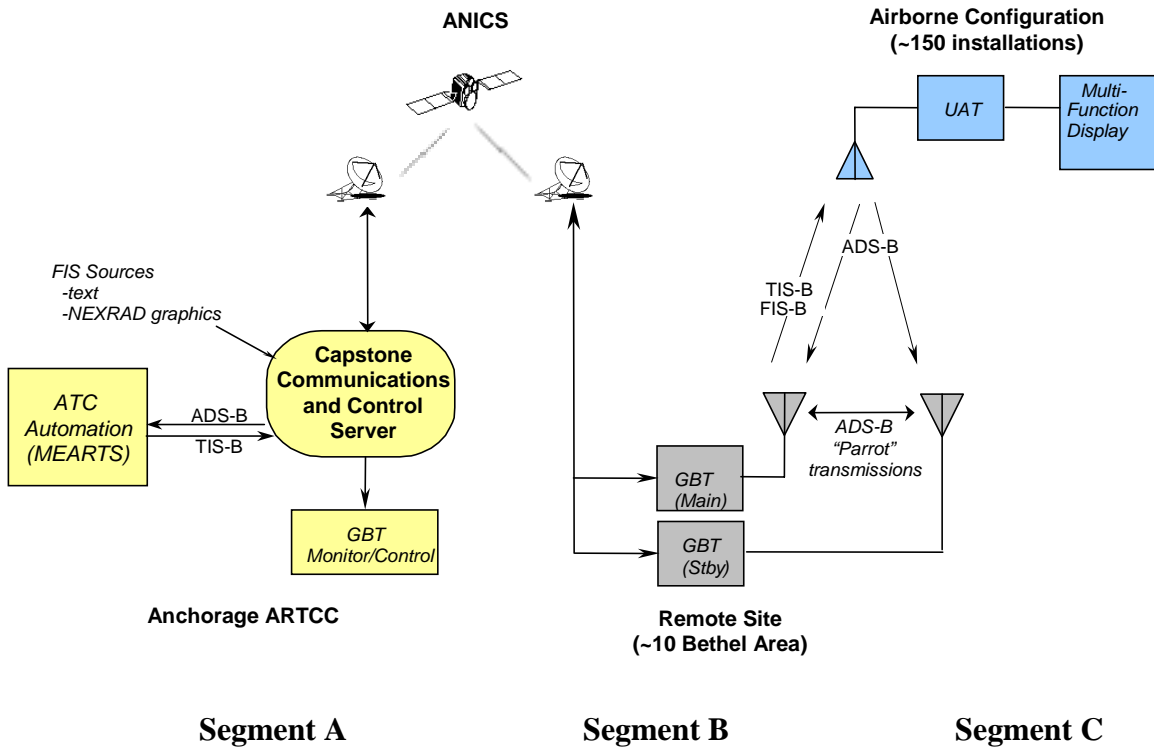

Figure 3-1. Target End-End Capstone Data Link Architecture

Segment A is located at Anchorage ARTCC and consists of the two major components. One is the ATC automation system known as MEARTS that incorporates ADS-B and radar data into its track processing. The second is known as the Capstone Communications and Control Server (CCCS) and performs the following main functions:

- Provides a multiplexing function for all traffic to and from the remote GBT, allowing multiple ground system applications access to each GBT with a single circuit connection. This multiplexing function is shown as the “Core Switch” in the Figures of Section 3.1.1
- Provides formatting, filtering and prioritization for all uplink message traffic to the GBT (FIS-B and TIS-B). This is shown as the “GBT Host” in the Figures of Section 3.1.1
- On an interim basis, the CCCS will also support a rudimentary Remote Maintenance Monitoring (RMM) user interface for use by the Maintenance Control Center (MCC) operators at Anchorage ARTCC (ZAN).

- Provides the application level support for FIS-B and TIS-B.

Segment B, remote site, includes the telecommunications link to the remote sites and the GBTs. The communication link can be provided by the ANICS or leased, long-haul commercial service. The GBTs capture the ADS-B data from appropriately equipped aircraft, and broadcast FIS-B/TIS-B data to the airborne segment. There are two GBTs (main and standby) at each site, each acts as a monitoring “parrot” for the other and as active backups.

Segment C is the airborne segment. The airborne UAT broadcasts the ADS-B data to the ground-based and airborne receivers. The UAT receives ADS-B data from the other aircraft UATs as well as FIS-B and TIS-B information from the GBTs. A MFD integrates and presents this data in a format usable by the flight crew.

3.1 Capstone Ground System

This section provides some detail on the planned evolution of the ground system, both at ZAN and for the remote GBTs.

3.1.1 ZAN

This section describes three phases of evolution of the ZAN infrastructure supporting Capstone. The first represents the current Radar-Like Services (RLS) Initial Operational Capability (IOC) configuration. The second represents the initial Operational Readiness Demonstration (ORD) configuration. In both of these phases, uplink applications (FIS-B, TIS-B) would remain “prototype” services, meaning they are under Capstone support. The final phase shows the configuration that achieves national level support for all Capstone-related functions. In this phase, the CCCS and uplink applications are fully certified for implementation in the rest of the NAS, potentially under later phases of Safe Flight 21.

3.1.1.1 RLS IOC Configuration

Figure 3-2 shows the ZAN configuration for this phase. Three separate networks are shown. The top one (in green) is the Operational Network providing RLS. This network has facility and national level support. The middle (in blue) is the Operational Testbed used primarily for testing of GBTs prior to their commissioning for operational use and for checkout of new MEARTS functions.

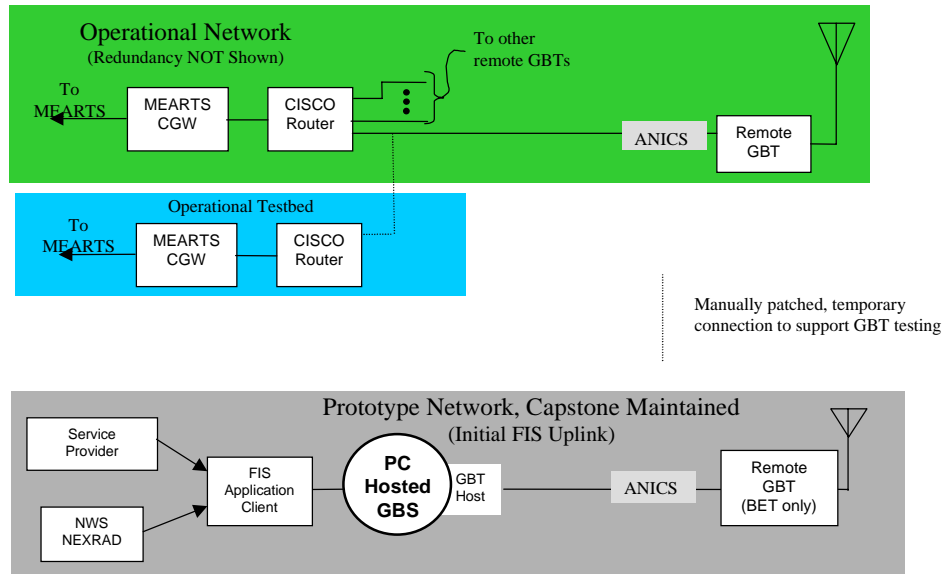

Figure 3-2. ZAN Configuration for RLS IOC

The third network (in grey) is the Prototype Network. This is currently used to provide uplink FIS service through a third GBT at Bethel. Support for this network is Capstone provided.

3.1.1.2 ORD Configuration

Figure 3-3 shows the ZAN configuration for ORD. In this phase the Operational Network is expanded to include the CCCS components. This will provide an interim RMM capability as well as provide access to the Operational GBT Network for uplink services. The use of the serial hardware splitter “Y” minimizes any risk of loss of ADS-B connectivity to MEARTS due to a CCCS failure. Uplink applications will continue to be Capstone supported through the Prototype Network. However, at this point each new CCCS interface (or client) will require a certification procedure to ensure they function properly with the established CCCS protocol. This certification would not include the actual applications. This phase represents a large step in that a significant number of tasks must be accomplished to achieve it such as documentation of CCCS software, and operational test plans for CCCS and RMM.

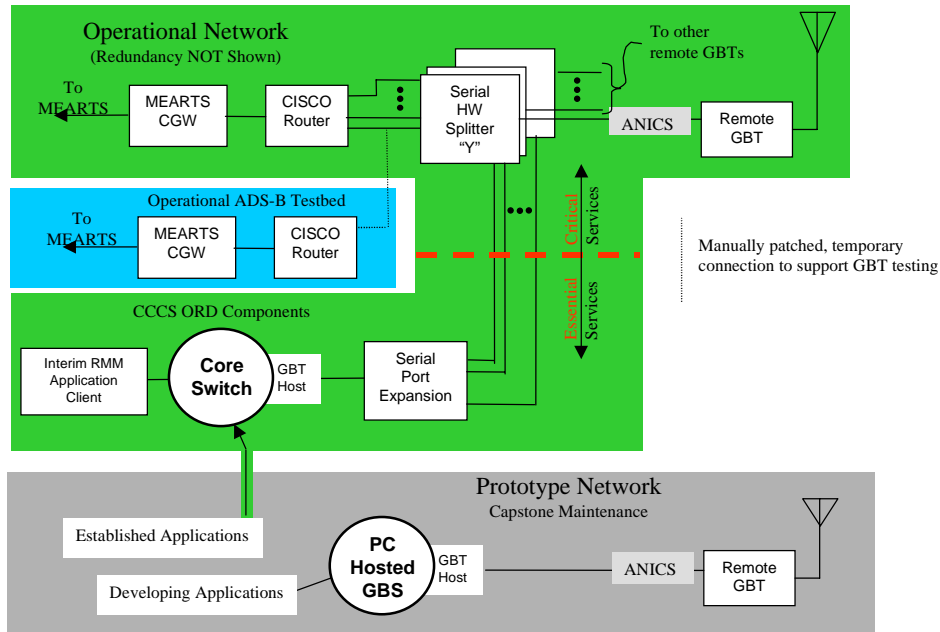

Figure 3-3. ZAN Configuration for Initial ORD

3.1.1.3 Final Configuration

Figure 3-4 shows the ZAN configuration in a final configuration. This configuration provides the most streamlined overall hardware architecture. It also assumes the Core Switch component of the CCCS has achieved an adequately level of certification and maintainability since it is in the MEARTS surveillance path. In this phase it is assumed that all uplink server functions are also mature and included in the ZAN Operational Network; these services no longer have to rely on Capstone maintenance. This represents the “NAS deployable” configuration applicable in later phases of Safe Flight 21.

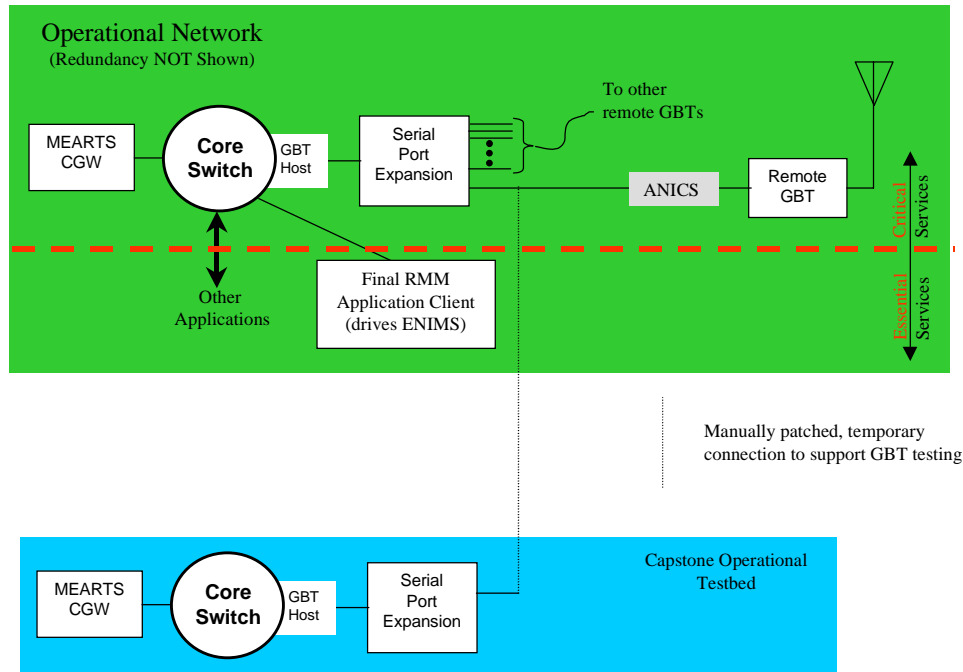

Figure 3-4. Final ZAN Configuration

3.1.2 Ground Broadcast Transceivers (GBTs)

The GBT is another element of Capstone that will evolve throughout the program. This evolution will also be of benefit to later phases of Safe Flight 21. Below is a listing of the major developments expected as the GBT matures:

- a) Support for ADS-B downlink, FIS-B uplink and status reporting (current capability)
- b) All functions in a) above plus remote configuration commands and reporting (now being implemented)
- c) Specification of a “second generation” GBT ground side interface (new specification now being developed)
 - Simplify internal GBT logic
 - Support a configurable ADS-B reporting filter
 - Better align ground interface data elements with RTCA data link standards
 - Increase bandwidth efficiency on ground circuits
 - Establishes common GBT interface for Capstone and Safe Flight 21 Ohio River Valley use
 - Include RMM capability
 - Basis for NAS GBT specification and Operational Support Service (AOS) software certification
- d) Upgrade of the air-interface of the GBT to be RTCA UAT Minimum Operational Performance Specification (MOPS) compliant

3.2 Capstone Avionics Phase I

On 2 February 2000, installation of government provided avionics began for approximately one hundred and fifty commercially operated aircraft. The Capstone program currently provides three UPS Aviation Technologies avionics products: the Apollo GX60 TSO-C129A certified GPS navigator/VHF communication radio (or GX50 TSO-C129A certified GPS navigator), the Apollo MX20 multi-function cockpit display (Capstone configured), and the UAT transceiver. Installation of these avionics is covered under a multiple make, model, and series FAA Supplemental Type Certificate (STC, No. SA02149AK) in accordance with UPS Aviation Technologies' Capstone STC Master Drawing List and the field approval process. The GX60 and MX20 are currently limited to supplemental VFR operations via the FAA approved Airplane Flight Manual Supplement or Supplemental Airplane Flight Manual for Capstone System Installation. The UAT has been upgraded and certified for ATC's use for IFR and VFR radar-like services. A description of the avionics is provided below with a block diagram depicted in Figure 3-3.

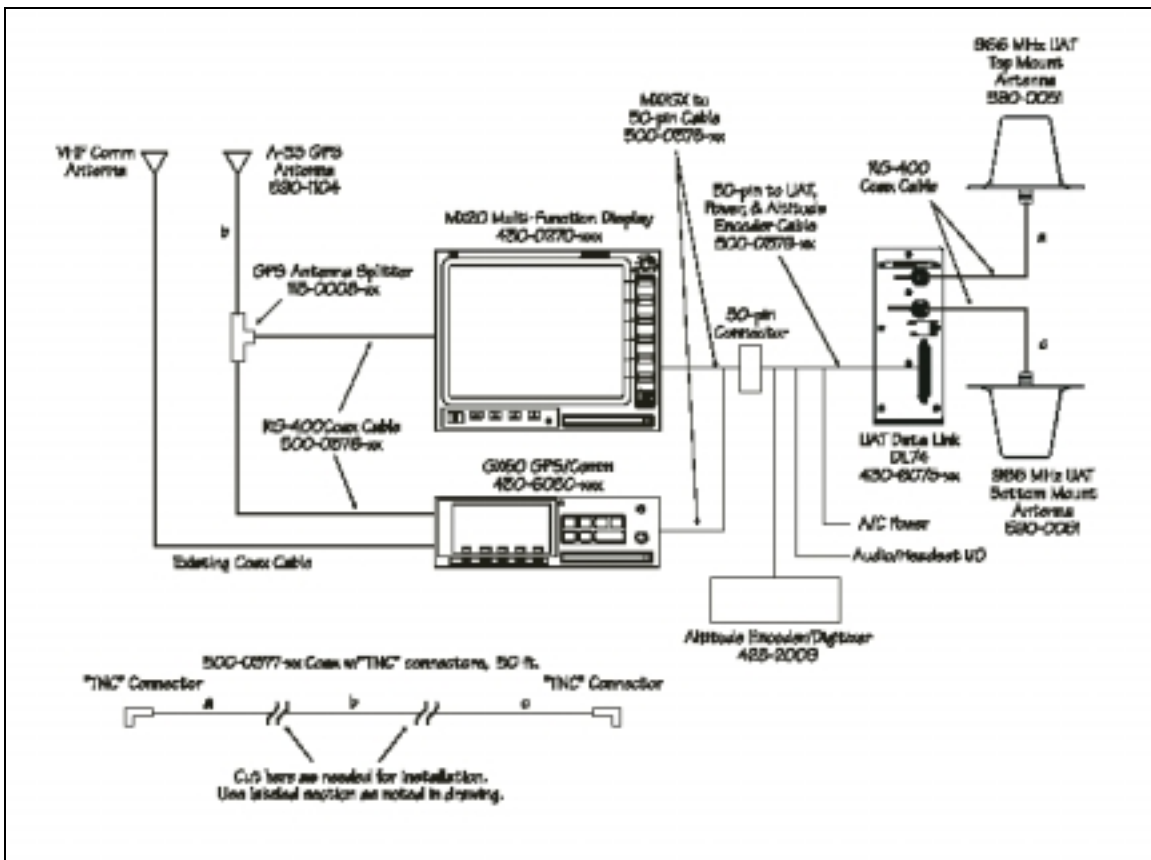

Figure 3-3. Capstone Avionics Block Diagram

- GX60 GPS/VHF Communication System is TSO-C129A Class A1 approved for IFR non-precision approach operation and also TSO-C37d, TSO-C38d and TSO-C128 approved 760-channel VHF communication transceiver. The Apollo GX60 provides navigational data to the pilot. The Capstone installation primarily targets aircraft, which are limited to VFR operations by the nature of equipage or

certification guidelines. However, some aircraft are incorporating the GX50/60 series in IFR capable avionics packages. (Note the GX50, provided on a few Capstone aircraft, is equivalent to a GX60 without the communication transceiver.)

- MX20 Multi-Function Display is capable of displaying ADS-B traffic, flight information service, moving map, terrain awareness information, and VFR/IFR charting functions. The Capstone version of the MX20 display has an internal GPS receiver to provide ADS-B timing and positioning for the UAT datalink. Further, the MX20 uses the internal GPS for own-ship display.
- UAT datalink radio will transmit the ADS-B position reports (as generated by the MX20) and receive data from other aircraft as well as FIS-B and TIS-B data transmitted by ground stations, and transfer that data to the MX20. Dual antennas are installed to resolve shadows created from various mounting configurations. One antenna is top mounted and the second antenna is bottom mounted.

3.3 AWOS III

The AWOS III equipment will meet at least the minimum functionality required by the Federal Aviation Regulations to support an instrument approach procedure for commercial operators. These weather sensors provide the following observations:

- Wind speed, direction, and gusts,
- Altimeter setting,
- Temperature and dew-point,
- Cloud height and sky cover,
- Visibility.

The equipment provides an automatic radio broadcast of observations and has the capability to provide remote weather observations via a telephone line or other connections. The equipment is capable of remote status and maintenance monitoring. Equipment specifications incorporate Airway Facilities Division's requirements for standardization, maintenance training, and supply support. The weather observation equipment is installed at airports by FAA technicians and/or contractors in accordance with the manufacturer's instructions.

Co-located with each Capstone AWOS is a weather camera that gives a periodic real-time digital picture of the airport-operating environment viewed via the Internet. Although not directly part of the Capstone program, a teaming of these two programs have helped reduce the cost and install time to put this capability into the field.

3.4 Consideration for Capstone Phase II in Southeast Alaska

The current Capstone architecture will be built upon for expansion to the Juneau/SE Alaska area. As new capabilities are explored and hardened in SE Alaska, the architecture may evolve to include those elements. The mountainous terrain and transient

aircraft population, different from Bethel/Y-K delta, dictates the need to explore next generation equipment, capabilities, and technologies.

The ground system described in section 3.1 will be used for SE Alaska, but given the need to see transient transponder equipped aircraft that will not be ADS-B equipped and for consistency with the lower 48 architecture, multi-lateration will be explored as a means to supplement the ADS-B system. Initially it is envisioned that multi-lateration/ADS-B will be a stand-alone tower display system (SATDS) for advisory use by controllers in Juneau – this is consistent with the current certification criteria under the FAA Automatic Surface Detection Equipment-X (ASDE-X) program. Working in coordination with the Safe Flight 21 Ohio River Valley program and Air Traffic Requirements organizations (ARN-300), the requirements for use of multi-lateration as a critical level system for terminal radar-like services will be evaluated⁶. Upon this higher-level certification, it may then be connected to MEARTS or other automation platforms. Another addition for the SE architecture will be the equipage of airport vehicles with ADS-B to evaluate runway incursion protection.

A Request for Information (RFI) has been issued for next generation avionics that explore new capabilities, such as WAAS capable GPS, enhanced see and avoid/traffic warning system, and cost effective Terrain Advisory Warning System (TAWS). These avionics will be compatible with the current (or upgraded) UAT ground and airborne infrastructure. Note, both the ground and airborne segments will meet the RTCA UAT MOPS.

In order to improve safety and access to locations in Southeast Alaska, additional voice communication capabilities, AWOS's, and GPS non-precision approaches will be fielded. The feasibility of lower-altitude IFR airways will be investigated to allow for more flexibility to remain free from icing conditions. Enhancing AFSS capabilities will also be explored.

4 DEMONSTRATION ACTIVITIES

The Alaskan aviation industry has entrusted the Capstone Program Office with the responsibility to procure, test, and deploy avionics and ground systems so as to provide specific safety and operational benefits. This section outlines the air and ground system activities underway to demonstrate the desired safety and operational enhancements. The following is a list of activities⁷ that Capstone is applying, that need to take place in order to guide an application from an initial concept to operational use.

- Development of a concept of operations,

⁶ FAA ARN-300, Requirements Evaluation Plan for Multi-lateration Proof of Concept, 21 February 2001.

⁷ RTCA, Inc., Development and Implementation Planning Guide for ADS-B Applications, DO-249, 6 October 1999.

- Description of the anticipated benefits and constraints,
- Development of operational procedures,
- Evaluation of the human factors,
- Establishment of end-to-end performance and technical requirements,
- Establishment of interoperability requirements for airborne and ground systems,
- Conducting a system safety assessment,
- Conducting developmental test and evaluation,
- Conducting operational test and evaluation,
- Certifying the systems (aircraft and ground),
- Obtaining operational approval from Flight Standards and Air Traffic,
- Developing an implementation transition strategy.

The following sections describe Capstone activities taking place in the Y-K Delta, Southeast Alaska, and at the program level. Specific budgeted equipment and costs are included in Attachment 1.

4.1 Phase I Bethel/Yukon-Kuskokwim (Y-K) Delta

The Y-K delta was identified by the Alaska aviation industry as the location to start the Capstone improvements. The following characterize this flying environment:

- A representative number of Alaskan accidents occurring in the area;
- No radar coverage below approximately 5000 feet;
- No highway structure connecting communities, making aviation the primary form of transportation;
- The aircraft fleet is geographically contained by mountains, limiting service to communities inside the area;
- Lower terrain in the immediate proximity reduces safety risks associated with the validation of Capstone components;
- Most of the 55 community airports in the area are without weather reporting capabilities, NAS instrument routes, or approach structures;
- Remote living conditions make it difficult for carriers to attract and retain experienced flight crews.

4.1.1 Status

4.1.1.1 Avionics

An amended STC for supplemental Visual Flight Rules (VFR) use of the avionics was issued 2 February 2000. This STC was again amended in August 2000 for FIS-B and on 19 December 2000 for use in IFR ADS-B radar-like services. As of May 2001 over 100 aircraft are equipped with Capstone. The following are the aircraft types covered under the STC and additional aircraft types may be included as the program expands.

- Raytheon A36, C90 and 200 Series;

- Britten-Norman BN-2 Series;
- Cessna 170 Series, 172 Various Series, 180 Series, 182 Series, 185 Series, 206 Series, 207 Series, 208 Series, 402 Series;
- DeHavilland DHC-2 Series, DHC-6 Series;
- Fairchild SA227 Various Series;
- Piper PA-28 Series, PA-31 Various Series, PA-32 Series, PA-34 Series;
- Partenavia P-68C;
- Short Brothers SC-7; and
- Other aircraft participating using field approvals: Piper PA-18, Casa 212-200

4.1.1.2 Ground Broadcast Transceivers (GBT)

As of May 2001, certified GBTs are installed at Bethel with developmental GBTs in place at Bethel and Anchorage. The Cape Romanzof, Cape Newenham, Aniak, and St. Mary's sites are installed, but still need to be commissioned. Operational ground sites have dual GBTs and communication paths back to Anchorage ARTCC to meet critical-level surveillance system requirements.

Operational sites installed:

- Bethel
- Cape Newenham
- Cape Romanzof
- Aniak
- St. Mary's

Operational sites for installation during FY2001:

- Site Summit
- Unalakleet
- Dillingham
- King Salmon
- Tatalina
- Sparrevohn

4.1.1.3 AWOS III

AWOS III units are installed at the following locations to enable IFR approach operations and better altimeter information for avionics.

- Holy Cross
- Scammon Bay
- Koliganek
- Kalskag
- Mountain Village
- St. Michael
- Russian Mission

Operational sites for installation during FY2001:

- Pilot Point
- Kipnuk
- Platinum

4.1.1.4 GPS Non-Precision Approaches

Stand alone GPS non-precision approaches have been developed and published for the following airports inside the Capstone area.

- Scammon Bay
- Holy Cross
- Kalskag
- Kipnuk
- Koliganek
- Mountain Village
- St. Michael
- Platinum
- Russian Mission

GPS non-precision approaches pending:

- Pilot Point
- Egegik

4.1.2 Continuing Activities

Work still remains to finish the Y-K Delta infrastructure and capabilities. Some of these relate to “hardening” the ADS-B radar-like services, while others include originally planned capabilities. The following sections outline these continuing activities and Appendix D is an action plan for completing them. Note Appendix D will be a living document until the activities are complete.

- Avionics Installations, UAT MOPS Upgrade, and Spectrum,
- GBT Installations,
- ZAN/Capstone Architecture Upgrade,
- Information Services and Flight Monitoring Completion,
- Continued Training,
- Bethel Special VFR Improved Operations,
- AWOS Commissioning,
- Potential Expansion/Enhancements.

A bi-weekly Capstone Engineering Coordination teleconference addresses the status of completing many of these activities, while weekly Capstone Staff meetings address the remainder.

4.1.2.1 Avionics Installations, UAT MOPS Upgrade, and Spectrum

As of May 2001, over 100 of the planned 150 aircraft have installed Capstone avionics. Install/aircraft out-of-service time and the need for some aircraft to fly to Anchorage for installation have made the process longer than anticipated. Capstone has set 30 June 2001 as the deadline for all installations in the original aircraft participant list. If the operators cannot provide a firm schedule that indicates a commitment to having their aircraft equipped, reallocation of the avionics will be made to others that wish to participate in the program. Additional spares are being provided in Bethel to permit rapid changeout of any malfunctioning units.

RTCA MOPS for UAT are planned for completion in January 2002. Capstone plans on upgrading all UATs and GBTs to be in MOPS compliance. Capstone is supporting the MOPS development with production Capstone avionics for bench testing as well as operational data and experience. The status of a permanent frequency assignment for UAT is being closely followed by Capstone. This frequency assignment is required in support of the MOPS as well as to enable self-equipage.

4.1.2.2 GBT Installations

Installation and commissioning of the operational GBT sites identified in Section 4.1.1.2 is planned for this fiscal year. There are several dependencies associated with this including Airways Facility workload, NATCA and Professional Airways Systems Specialists (PASS) coordination, and infrastructure upgrades at ZAN. Appropriate GBT specifications and requirements will also be generated to allow for future expansion.

4.1.2.3 ZAN/Capstone Architecture Upgrade

Various items were identified leading to IOC of ADS-B radar-like services that were adequate for IOC, but are required to be upgraded prior to ORD and further expansion of the system. These include:

- ZAN Local Area Network upgrade,
- MEARTS upgrades for altitude sectorization,
- CCCS documentation and certification (include FIS-B, TIS-B, flight monitoring),
- RMM upgrades for GBTs (includes modifications to GBTs, certification of CCCS, display application for MCC),
- Interface Control Documents (ICDs) and formal logistics support (e.g., continued operational supportability, service life extension) and certification for the above capabilities need to be completed.

This is a high-priority activity for Capstone working with Airway Facilities (AF), Air Traffic (AT), and the Office of Air Traffic Systems Development (AUA). The resources (money and personnel) are being put in place to complete these tasks. See Appendix D for Action Plan.

4.1.2.4 Information Services and Flight Monitoring Completion

Original capabilities designated for Y-K Delta include FIS-B, TIS-B, and operator flight monitoring. Basic FIS-B products (i.e., text METAR and TAF, graphical NEXRAD) are available via a separate Bethel GBT on the Prototype Network. It is planned to begin using the Operational GBT Network for FIS-B when the CCCS is approved and in place. Expanded services will also be explored. Note the avionics are already certified to receive and display the basic FIS-B products. Standards for TIS-B are still being defined and Capstone is working with the Safe Flight 21 Ohio River Valley operational evaluations to evaluate how best to provide TIS-B data to the aircraft. ADS-B flight monitoring is currently available via the internet through Skysource for IFR aircraft. A modification to MEARTS to allow VFR ADS-B aircraft tracks through Skysource is planned for Fall 2001.

4.1.2.5 Continued Training

The need for continued training on the functionality, maintenance, and procedures associated with Capstone technology has been highlighted, especially as additional pilots, controllers, and maintenance technicians start using it.

The University of Alaska provides initial and recurrent training on the Capstone avionics for representatives from the various participating commercial carriers. It is the company's responsibility to ensure all their pilots using the Capstone equipment are properly trained. A training supplement for ADS-B radar-like services has been provided to the operators and this targets items such as use of ICAO identifier. Flight Standards personnel also need to be properly trained to ensure the operators are meeting the requirements.

With the advent of ADS-B radar-like services, controller training is playing a prominent role. As specialized procedures are developed to make use of ADS-B to provide better services in and around Bethel (e.g., Bethel airspace re-sectorization), additional training on the controller and pilot side will need to take place.

As the ground system expands (e.g., additional GBTs) and matures (e.g., CCCS certification) Airway Facilities maintenance technicians will have the continued need for training, both in the new pieces of the architecture as well as trouble shooting any issues that might arise.

Training and/or familiarization for other participants in the airspace system also needs to continue. This includes the AFSS and ATCT personnel, and the general aviation community that may start using the Capstone technology in the future.

4.1.2.6 Bethel Special VFR Improved Operations

Now that the infrastructure for ADS-B radar-like services has been implemented in Bethel, there is a need to develop optimized air traffic procedures to improve the safe and efficient control of traffic in that area. This will include such things as airspace design and addressing the need to enhance tower controllers visual acquisition of traffic by use of a display in the Bethel tower. These activities should be a joint effort between the Bethel Operators, Bethel ATCT, Anchorage ARTCC, and FAA Alaskan Region Air Traffic Division. See Appendix B.

4.1.2.7 AWOS Commissioning

Of the 10 AWOSs identified in section 4.1.1.3 seven have been commissioned and there are three remaining. Additional AWOS sites have been identified by the Alaskan aviation community and these will be included in future activities.

4.1.2.8 Potential Expansion/Enhancements

The following are potential expansions and/or enhancements to the Bethel/Y-K delta area capabilities. There are GBT coverage gaps at low altitudes that exist because all the Phase I sites are co-located with ANICS facilities, additional non-ANICS sites may be installed (e.g., Kipnuk, Anvik). A proposal put forward by the Alaskan industry is to expand the current geographic Capstone Y-K Delta demonstration area farther north, south, and east. This will be explored in the future, but at this time resources will be used to harden the capabilities in the current area. A capability that has been demonstrated is the equipping of airport surface vehicles with low-power ADS-B transmitters for display in the aircraft or for ATC. The current avionics have the capability to display these targets, however some modifications to the ground system automation will be needed for proper filtering of this data. All in all, this could be a very inexpensive means of improving runway safety. Although not a major cause of fatal accidents in Alaska, this is a high priority item for nation-wide improvements in aviation safety. Capstone is continuing to explore new technologies and expansion of demonstration areas, however, careful consideration must be given to limited resources and completion of the first phases prior to moving towards future activities.

4.2 Phase II Juneau/Southeast (SE) Alaska

Congressional language in the 2001 budget provided direction and funding to expand Capstone into Southeast Alaska. Capstone capabilities will be initially provided in the Juneau area and then expanded. New capabilities that have potential for providing safety benefits in this terrain-constrained area will also be evaluated. The following characterize this flying environment:

- A representative number of Alaskan accidents occurring in the area;
- No radar coverage below approximately 10,000 feet;
- No highway structure connecting communities, making aviation the primary form of transportation;
- The majority of the aircraft fleet is geographically contained by mountains, limiting service to communities inside the area; however, there are transient aircraft to/from lower 48 and Canada that fly through the area;
- Higher terrain and fiords in the immediate proximity elevates the validation and requirements of Capstone components to a high criticality level;
- Many of the community airports and seaplane bases in the area are without weather reporting capabilities, NAS instrument routes, or approach structures;
- Remote living conditions make it difficult for carriers to attract and retain experienced flight crews.

The following list of safety initiatives were compiled by the Capstone Southeast Alaska Aviation Industry Council:

1. Useable IFR infrastructure: position airways and approaches at locations and altitudes that are useable by the types of aircraft based in southeast Alaska.
2. Onboard traffic display and terrain database: cockpit display of terrain and traffic information. Traffic information should be displayed for both participating and nonparticipation aircraft near terminal areas e.g., Juneau airport.
3. Navigation systems: enhanced onboard navigation system to allow stand alone GPS enroute navigation and approaches.
4. Flight Monitoring: ability to monitor/flight follow aircraft by operators and dispatchers.
5. Affordability & space/weight concerns.
6. Runway incursion.
7. On-board weather sensors.

Based on the above industry input, the Capstone FAA Team established the following high-level objectives for Southeast Alaska:

- Improve Safety
 - Improve/enhance IFR infrastructure for the types of aircraft in SE Alaska (e.g., improve surveillance, improve weather reporting/observations, improve navigation capability),
 - Reduce CFIT,
 - Reduce collisions (mid-air and surface),

- Improve communications.

4.2.1 Status

4.2.1.1 Southeast Action Plan

An action plan to include operational roles and responsibilities, procedures, requirements development, operational supportability, service life extension, and measures for achieving user benefits is under development. This plan will be based on the requirements outlined in the operational concept document in Appendix C. This action plan will be developed within the Alaskan Region, but coordinated with Air Traffic System Requirements (ARS) and other relevant national organizations. See Appendix E for the draft Action Plan.

4.2.1.2 Avionics

The FAA Capstone Program issued a RFI for avionics to meet the needs of Southeast Alaska. The purpose of the RFI was to seek commercial entities interested in participating in Capstone Phase II, where commercial vendors are expected to serve in a partnership role with the FAA during the test period. Based on the information received from the RFI, a Request for Proposal will be developed and should be released in May of 2001. Vendor down select and contract award is planned to occur by late CY2001, with certification and initial installs by late Spring 2002.

The intent of the avionics for Phase II is to reduce pilot workload, increase pilot situational awareness, and increase navigational performance during IFR operations and may include the following functions:

- A WAAS capable GPS Navigation System integrated into a MFD.
- A MOPS compliant UAT datalink broadcasting ADS-B
- Display of ADS-B air-to-air traffic targets along with TIS-B targets on a MFD and Primary Flight Display (PFD) when appropriate. Traffic warnings should also be provided.
- Terrain information will also be displayed on the MFD and PFD. A TAWS that meets TSO-151a, Class B, and should work in both small aircraft and float equipped aircraft.
- FIS-B information, text and graphics, will be displayed on the MFD.
- Display of primary flight information (pitch attitude, roll attitude, heading, track angle, flight path or velocity vector, rate of climb, airspeed, etc.) will also be provided on a primary flight display.

- Weather sensors may be provided as an option that can down link weather information over the UAT datalink.

4.2.1.3 GBT Installation

Certified GBTs will provide the ADS-B target data for use by controllers at Anchorage ARTCC. They will also provide the uplink broadcast of FIS-B and TIS-B information, once these services are available. Certified GBTs will be installed initially in the Juneau area with others to follow as coverage and site analyses are completed.

4.2.1.4 AWOS III Installation

There is a planned AWOS III installation at Hoonah in FY2001. Other AWOS III locations will be identified during FY 2001 to enable IFR approach operations and better altimeter information for avionics.

4.2.1.5 GPS Non-Precision Approaches

A standalone GPS non-precision approach will be developed and published for Hoonah. Other locations will be identified to improve remote airport/village access. Point in space approaches for seaplane operations will also be explored.

4.2.1.6 Enhanced Navigation and Lower Altitude Routes

GPS and the WAAS will be evaluated for navigation use in Southeast Alaska in regards to lower altitude IFR routes. The initial capability will be to improve lateral navigation (LNAV) by possibly defining Minimum Enroute Altitudes (MEAs) via satellite navigation reception. Current Terminal Instrument Procedures (TERPS) standards for Minimum Obstacle Clearance Altitude (MOCA) will apply. This should allow for the MEAs to be lowered closer to the MOCAs (in some cases 7000 feet lower) allowing a more usable IFR infrastructure. Availability, accuracy, integrity, and continuity of GPS/WAAS compared to current ground-based navigation aids will be considered.

4.2.1.7 Multi-lateration

The use of multi-lateration will be explored to augment surveillance coverage in non-radar environments of transponder equipped aircraft that are not equipped with ADS-B. The first use of multi-lateration will be as an enhanced visual acquisition/situational awareness tool for tower controllers. It is proposed to install a stand-alone multi-lateration/ADS-B system at the Juneau airport with displays in the Tower and possibly in airport/airline operations and the AFSS. This system would be a derivative of the ASDEX system and be similar to ones being tested by Safe Flight 21 in the Ohio River Valley. This system will be evaluated in support of both airport surface/runway incursion protection as well as terminal area radar-like services. Based on successful testing and requirements evaluation, work could lead towards certification as a critical-level system for terminal radar-like services. Potential FY2001 work to introduce multi-lateration will include surveys for siting of sensors and installation of the fusion processor and displays.

4.2.1.8 Communication Infrastructure

Additional communication sites will be required to provide voice communications between pilots and ATC in SE Alaska where ATC services will be available at lower altitudes, for example in Stevens Passage. Surveys will be conducted to determine installation sites, with initial installs in Stevens Passage.

4.2.1.9 Procedures and Training

The need for procedures and training on the functionality, maintenance, and procedures associated with Capstone technology has been highlighted, especially as additional pilots, controllers, and maintenance technicians start using it. University of Alaska pilot training efforts will be extended to Southeast Alaska operators. This will begin just prior to avionics installations in FY 2002. ATC procedure development and controller training will also be provided, especially for the supplemental VFR use of multi-lateration and ADS-B by the Juneau tower. Airway Facilities maintenance technicians will have the continued need for training, both in the new Capstone systems (e.g., multi-lateration) as well as the matured pieces (e.g., AWOS, GBTs). Training for the AFSS personnel and other potential users of Capstone technology will also be necessary.

4.2.1.10 Information Services and Flight Monitoring Capabilities

Information services (i.e., FIS-B, TIS-B) and flight monitoring capabilities will also be implemented in the Juneau/SE demonstration area. As these capabilities are matured in the Bethel/Y-K Delta, they will then be transferred to SE. In addition, new ways of providing this type of information will also be explored, such as via the standalone multi-lateration/ADS-B system in Juneau.

4.2.1.11 Runway Incursion Protection

Runway incursion protection will be explored in SE Alaska. Although not a major cause of aviation fatalities in Alaska, this is a major safety concern in the NAS. As mentioned under Section 4.2.1.7, the use of multi-lateration and ADS-B as a terminal surveillance system will be explored. In addition, airport vehicles will be equipped with low power ADS-B transmitters for display to the tower controllers, airport operations, and to the pilots of properly equipped aircraft. This is consistent with work underway by Safe Flight 21 in the Ohio River Valley.

4.2.2 Continuing Activities

This section is not applicable at this time.

4.3 Program Activities

4.3.1 Test Plan Activities

Capstone will continue to develop test and certification plans for the various ground and avionics systems per operational applications as appropriate (e.g., as was done for ADS-B radar-like services). Test documentation may consist of test and evaluation master plans, certification test plans, human factors and safety evaluations, and technical reports on the ground and avionics systems.

4.3.2 Operational Evaluation and Safety Study

Evaluation within real-time commercial flight operations is being conducted to monitor Capstone systems performance and to collect operational feedback from the pilots and controllers. The operational evaluation for the airborne systems began in February 2000 with the initial avionics installations and is largely accomplished by University of Alaska (UAA) using pilot surveys and questionnaires. Operational evaluation of the ground systems began with the Bethel site in June 2000. As of 1 January 2001, formal data logging and monitoring are being accomplished under standard critical data recording (CDR) within MEARTS. As Capstone demonstrations move into SE Alaska, similar data will be gathered in this different operational area, for new capabilities, and in a different traffic environment (e.g., mixed equipage). Acceptable levels of performance, reliability, integrity and pilot/controller operational feedback will permit the transition to statewide implementation.

The UAA is under contract to perform a three-year study addressing the safety and benefits that result from the Capstone Program and associated new flight procedures in the Bethel/Y-K delta area and this will be extended for SE Alaska. The safety study includes:

- Documenting a baseline of Capstone area operations (e.g., accidents/incidents/near mid-air collisions, carriers/operators, pilots, airports, approaches, nav aids and all facilities to include weather, communication, and navigation).
- Monitoring and documenting infrastructure changes within Capstone area (e.g., IFR approaches established, ADS-B ground system coverage, Capstone avionics acceptance/usability, operator reliance on avionics, equipment failure rate, training, accidents/incidents/near mid-air collisions, human factors relating to usefulness and acceptance).
- Preparing annual and final reports on safety change measured (e.g., review of accidents/incidents/near mid-air collisions, analysis of pre-Capstone/post-Capstone safety posture, survey of Capstone users).

The draft baseline report was issued in July 2000 and is available on the Capstone web site: <http://www.alaska.faa.gov/capstone/docs/docs.htm>. Annual reports will cover each year of the Capstone program.

4.3.3 Cost Benefit Analysis

The Capstone and Safe Flight 21 Programs are participating in a cost benefit analysis to help document the rationale for future Government and operator/pilot investment in the Capstone technologies. The FAA Office of System Architecture and Investment Analysis (ASD) is leading this analysis effort, which covers statewide implementation, for 2002-2005. The analysis reviews the current investment, the anticipated value of improvements in safety and efficiency, the projected additional FAA expenses, and the cost of aircraft equipage beyond the FAA provided avionics. Included in this process is

the installation of automated weather stations, the implementation throughout Alaska of ground stations, the installation of multi-lateration/ADS-B systems for 3 major airports, and ADS-B equipment installed in ground vehicles to support improved surface operational awareness and to help reduce runway incursions.

4.3.4 Operational System Safety Review

A Capstone System Safety Program Plan (CSSPP) has been developed and is documented in the Capstone ADS-B Radar-Like Services Test and Evaluation Master Plan. This CSSPP includes continued hazard tracking and risk resolution for the Y-K Delta Capstone Phase I and will also cover new efforts for SE Alaska and Capstone Phase II. Capstone in coordination with the FAA Office of System Safety (ASY) and the Alaskan Region will perform required System Safety Review analyses. A Capstone System Safety Working Group has been formed that includes Alaska operations and safety specialists. These analyses include hazard identification, risk assessment, severity and probability determination, and controls and mitigation documentation specific to Capstone avionics, ground systems, and procedures.

4.3.5 ATS Readiness Review and IOT&E Issues

An Air Traffic Services (ATS) Readiness Review was conducted as an independent analysis of risks associated with Capstone implementation of ADS-B radar-like service. Several issues and recommendations were identified, however none of which delayed the operational start date of 1 January 2001. These issues and recommendations are being addressed by the appropriate organizations and the Office of Independent Test and Evaluation (ATQ) is continuing to monitor Capstone status through participation in Capstone staff and engineering meetings as well as periodic informational visits. Additional readiness reviews and/or a formal Independent Operational Test and Evaluation (IOT&E) will be performed as Capstone capabilities mature.

4.3.6 Lessons Learned Documentation

The experience and lessons learned being gained through Capstone efforts need to be documented. Various activities will serve as a means to capture these lessons – to include the System Safety Review Process, staff meetings and offsite discussions, and participation in industry standards, aviation conferences, and Safe Flight 21 activities.

5 TRANSITION TO NAS IMPLEMENTATION

5.1 Statewide

As Capstone measures the benefits gained during the demonstration period, funding will be placed into the budget for implementation of ground infrastructure systems. Attachment 2 contains funding planning wedges for statewide implementation. Implementation locations will be incorporated into an integrated Alaskan Region systems plan. Various Alaskan Region lines of business will need to participate in the Acquisition Management System (AMS) planning in order to successfully portray and defend the Capstone implementation.

Figure 5.1 depicts the general capabilities for both Capstone Phase I and II and what is “inside” Capstone vs. what is beyond Capstone. The dashed line is meant to show that those items that remain above the line continue as research items, while those systems that are “hardened” and are ready for deployment into the NAS, would be accepted by the implementing organization. Capstone provides program-funding wedges for future year implementation, so that there is no gap between the Capstone technology demonstrations, the continued operation at the demonstration locations, and further implementation. All of the technologies that Capstone provides for statewide implementation will be developed to meet NAS standards.

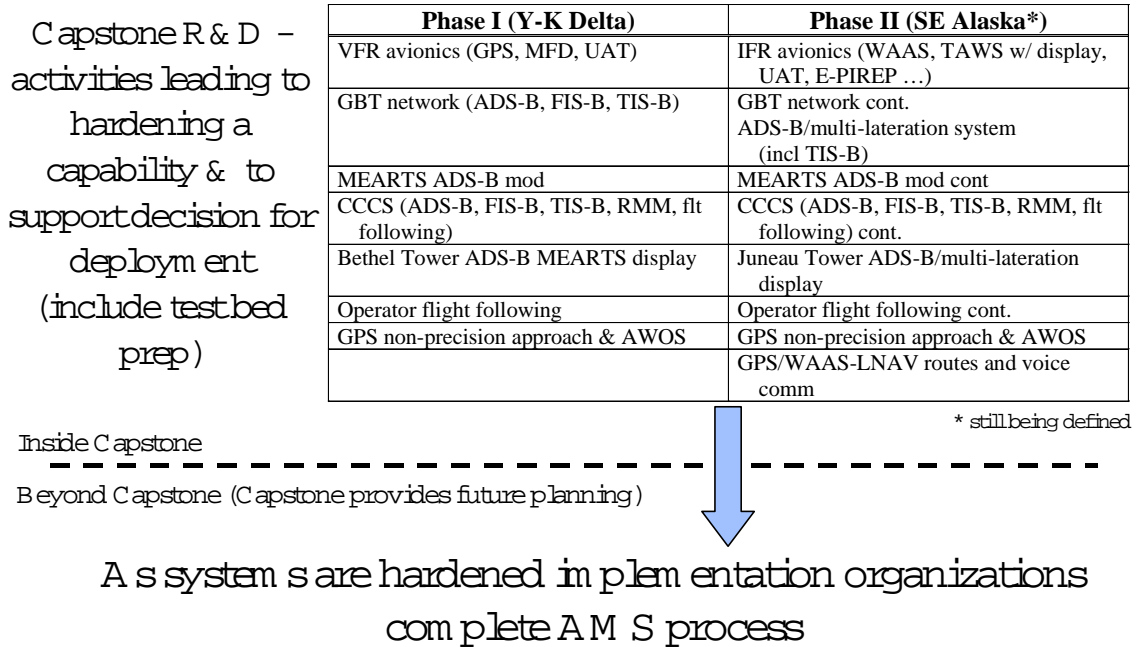

Figure 5.1 Capstone Activities

5.2 National

The Alaskan Region and Capstone will work with the national Air Traffic System Requirements (ARS) and System Architecture and Investment Analysis (ASD), organizations, so matured Capstone systems can begin a transition to other parts of the NAS. The Alaskan regional notices and documentation developed under Capstone can be used as a basis for national orders and policy. Additional NAS requirements will need to be considered, but Capstone can provide answers to technical, operational, and cost/benefit questions that enable the FAA and industry decision-makers to make future CNS technology implementation choices.

6 CAPSTONE PROGRAM MANAGEMENT

6.1 Capstone Organization

The following describes the structure and responsibilities of the Capstone management process. This management structure provides a platform for program oversight and coordination, a means for participation in Capstone demonstration and subsequent

implementation activities by appropriate FAA offices, and coordination with the Alaskan aviation industry.

6.1.1 Capstone Management Review Board

The Capstone Management Review Board provides broad FAA policy guidance, advice, and counsel to the Capstone Program Office. The following FAA executives or their designees provide connectivity between primary lines of business impacted by the Capstone validation:

- Associate Administrator for Research and Acquisitions, ARA-1,
- Assistant Administrator for Region and Center Operations, ARC-1,
- FAA Director for Communications, Navigation, and Surveillance, AND-1,
- Product Lead for Advanced Technologies, AND-500,
- Administrator, Alaskan Region, AAL-1 (Chair),
- Manager, Flight Standards Division, AAL-200,
- Manager, Airway Facilities Division, AAL-400,
- Manager, Air Traffic Division, AAL-500,
- Manager, Airports Division, AAL-600,
- Manager, NAS Implementation Center, ANI-700,
- Manager, Aircraft Certification Office, ACE-115N,

The Management Review Board convenes approximately once per quarter, or as requested by any executive member, to review the Capstone Program progress. The Product Lead for Advanced Technologies, AND-500, is responsible for day-to-day coordination with the Capstone office on matters concerning Capstone funding and planning.

6.1.2 Capstone Program Office (CPO)

The CPO operates under the direct authority of the Alaskan Regional Administrator, AAL-1, for all coordination efforts during the project. The CPO is led by the Capstone Program Manager and staffed on a full-time basis by a small number of FAA personnel as well as contract support from NAS Implementation Support Contract (NISC) II and The MITRE Corporation Center for Advanced Aviation System Development. Members of the CPO work within their straight-line divisions as program requirements dictate, to support and assist the CPO as described below. Division representatives attend scheduled meetings and perform services as the need arises.

The CPO representatives assist the Capstone Program Manager with planning, scheduling, budgeting, implementing, and evaluating the Capstone Program. FAA representatives ensure appropriate program coordination is effected within their own straight-line organization at the regional and national levels.

The Capstone Program Office is responsible for the following:

- Developing the Capstone Program architecture and defining system interfaces.
- Advocating and supporting technology demonstrations under the Safe Flight 21 “Free Flight Operational Enhancements” program umbrella.
- Maintaining a procurement process featuring the selection and assignment of a responsible lead office for each major acquisition and a method for documenting agency consensus for procurement decisions.
- Promoting, on a regional and national basis and with industry, participation in Capstone Program planning and activities.
- Developing program plans, specifications, cost estimates, selection criteria, and other procurement documentation for acquisition of Capstone systems and equipment.
- Establishing an integrated Capstone program schedule. The schedule will include program goals, acquisition schedules, equipment delivery, and budget wedges for statewide implementation; and will illustrate program dependencies.
- Implementing a progress reporting system to facilitate the flow of information and assist with communication and coordination mechanisms.
- Coordinating all programs and activities directly contributing to the accomplishment of the Capstone Program.
- Preparing future budget requirements for equipment services, personnel, and other resources with the Safe Flight 21 office.
- Coordinating the development of test and evaluation plans including schedules, responsibilities, and field support requirements for operational capability demonstrations, contractor acceptance testing, certification, and flight check as necessary.
- Working with the implementing organization to develop and maintain database tools to support the various aspects of the Capstone Program implementation. Where applicable, these database tools will be linked to the master program schedules.

- Preparing “after action” reports detailing program accomplishments, lessons learned, and recommendations to achieve future Free Flight Operational Enhancements on a national basis.
- Supporting Safe Flight 21 activities to develop and implement plans and schedules for Capstone activities in the Alaskan Region which support evaluation of Free Flight Operational Enhancements and ADS-B data link.

6.1.3 Capstone Program Office Staffing

The Capstone Program Office is staffed and supported through temporary assignments by the Alaskan Region straight-line organizations and the Regional Administrators staff. A major requirement of the Capstone Program is to develop, test, and certify aircraft, air traffic control, and flight standards procedures. The assigned representatives from the organizations listed in Table 6-1 are responsible for completion of the related tasks. Each line of the business provides inputs to detailed work plans to ensure project timelines are identified and maintained, air traffic and pilot procedures are identified as necessary, and progress is documented.

Office staffing consists of, but is not limited to, the following representatives:

- Office Manager,
- Business Manager,
- Administrative Officer,
- Flight Standards,
- Air Traffic Control,
- Airways Facilities,
- National Airspace System Implementation,
- Aircraft Certification,
- Logistics,
- Legal Counsel,
- Contractor assistance,
- Liaison to the Safe Flight 21 Program Office in Washington DC, and
- AVN procedures.

Capstone Elements	Office of Primary Interest (OPI)
Ground Systems	
MEARTS adaptation	AF/AT
Gateway for MEARTS (Automation, Software)	AF/AT
Capstone Server	AF
FIS	AT
AT LAN network	AF/AT

Capstone Elements	Office of Primary Interest (OPI)
Telecommunications links	AF
GBT	AF/AT
AWOS III	ANI
Spectrum	AF/ACO
Multi-lateration	AF/AT
Flight Monitoring	AF/FS
Flight check	FS/AVN
Avionics	
GPS Navigator	ACO/FS
Multi-Function Display	ACO/FS
UAT Transceiver	ACO/FS
WAAS	ACO/FS
Procedures/Operations	
Procedures (ATC, pilot, maintenance)	AT/FS/AF/ANI
Training program (ATC, pilot, maintenance)	AT/FS/AF/ANI
Operational Approval	AT/FS
GPS non-precision procedures	AVN
IFR Routes	AVN
Contract oversight at UAA	FS

Table 6-1 Capstone Elements and OPIs

6.1.4 Alaska Aviation Industry Capstone Coordination

Organizations actively involved with the Capstone Program include the Aircraft Owners and Pilots Association (AOPA), Alaska Airmen’s Association (AAA), Alaskan Aviation Safety Foundation (AASF), Alaska Air Carriers Association (AACCA), Cargo Airline Association (CAA), and Northern Alaska Aviation Users Group (NAAUG). They represent the varied interests of aviators in the state. These organizations bring users’ concerns and issues to the table and help insure a continued dialogue with aviators.

In addition to the above organizations, User Groups in both Bethel and Juneau have been formed to ensure direct feedback and coordination from operators within those unique environments.

ATTACHMENT 1 CAPSTONE REQUIREMENTS AND COSTS (FY'99 - '01)

Category	FY99	Comments	FY00	Comments	FY01	Comments

ATTACHMENT 2, COST AND SCHEDULE FOR STATEWIDE IMPLEMENTATION F&E (FY'02 - '05)

APPENDIX A ACRONYMS

AAA	Alaska Airmen's Association
AACA	Alaska Air Carriers Association
AAL	FAA Alaskan Region
AASF	Alaskan Aviation Safety Foundation
ACE	Small Airplane Directorate
ADS-A	Automatic Dependent Surveillance-Addressed
ADS-B	Automatic Dependent Surveillance-Broadcast
AF	Airway Facilities
AFSS	Automated Flight Service Station
AIR	Aircraft Certification Service
AND	Communications, Navigation, and Surveillance Systems Research and Acquisitions
ANI	FAA Engineering Center
ANICS	Alaskan NAS Interfacility Communications System
AOPA	Aircraft Owners and Pilots Association
AOS	Operational Support Service
ARA	Associate Administrator for Research and Acquisitions
ARC	Associate Administrator for Region and Center Operations
ARTCC	Air Route Traffic Control Center
ASD	Office of System Architecture and Investment Analysis
ASY	Office of System Safety
AT	Air Traffic
ATCT	Air Traffic Control Tower
ATP	Air Traffic Procedures
ATQ	Office of Independent Test and Evaluation
ATS	Air Traffic Services
AUA	Office of Air Traffic Systems Development
AVN	Aviation Systems Standards
AWOS	Automated Weather Observing System
CAA	Cargo Airline Association
CCCS	Capstone Communications Control Server
CFIT	Controlled Flight into Terrain
CNS	Communications, Navigation and Surveillance
CPO	Capstone Program Office
DSR	Display System Replacement
DT&E	Developmental Test and Evaluation
FIS-B	Flight Information Services-Broadcast
GBT	Ground broadcast transceivers
GPS	Global Positioning System
IFR	Instrument Flight Rules
IOC	Initial Operational Capability
IOT&E	Independent Operational Test and Evaluation

LAAS	Local Area Augmentation System
MASPS	Minimum Aviation System Performance Standards
METAR	Meteorological Aviation Report
MCC	Maintenance Control Center
MFD	Multiple Function Display
MEARTS	Micro-En Route Automated Radar Tracking System
MOCA	Minimum Obstacle Clearance Altitudes
MOPS	Minimum Operational Performance Specification
MSAW	Minimum Altitude Safe Warning
NAAUG	Northern Alaska Aviation Users Group
NAS	National Airspace System
NATCA	National Air Traffic Controllers Association
NAVAID	Navigational Aid
NEXRAD	Next Generation Weather Radar
NISC	NAS Implementation Support Contract
NOTAM	Notice to Airmen
NTSB	National Transportation Safety Board
ORD	Operational Readiness Demonstration
PASS	Professional Airways Systems Specialists
PFD	Primary Flight Display
PIREP	Pilot Report
POI	Principal Operations Inspector
RFI	Request for Information
RLS	Radar-Like Services
RMM	Remote Maintenance Monitoring
SE	Southeast
SIGMET/AIRMET	Significant Meteorological Information/Airman's Meteorological Information
STC	Supplemental Type Certificate
SUA	Special Use Airspace
SVFR	Special Visual Flight Rules
TAF	Terminal Area Forecast
TAWS	Terrain Advisory Warning System
TERPS	Terminal Instrument Procedures
TIS-B	Traffic Information Services-Broadcast
SETA	System Engineering and Technical Assistance
UAA	University of Alaska, Anchorage
UAT	Universal Access Transceiver
VFR	Visual Flight Rules
WAAS	Wide Area Augmentation System
WJHTC	William J. Hughes Technical Center
Y-K	Yukon-Kuskokwim
ZAN	Anchorage ARTCC

APPENDIX B
BETHEL/Y-K DELTA IMPROVED SPECIAL VFR OPERATIONS CONCEPT

**ADS-B Monitor in the Bethel
FAA Contract Tower**

White Paper
April 24, 2001

Prepared for ATP-1
By Alaskan Region Air Traffic Division (AAL-500)

1.0 Executive Summary

Delays associated with the handling of Special VFR aircraft in Bethel, Alaska has been a problem for many years. Regular meetings with the aviation industry has resulted in a vision of how the FAA can effect positive change in the way air traffic is managed in this area. These changes can significantly improve the safety and efficiency of operations, saving the system users time and money in the process. This white paper explores a couple of options for utilizing new innovative technologies to place visual information, in the form of a DBRITE-like display, in the Bethel FAA Contract Tower (FCT) to aid in substantially reducing delays and improving safety. Based on this information, we believe it is in best interest of all involved and recommend the FAA move forward with the installation of this display in Bethel FCT.

2.0 Introduction

The Bethel area has presented many challenges in our effort to provide safe and efficient air traffic control services for the local aviation community. The Alaska Region's Capstone Program, with its primary focus on improving the safety and efficiency of aviation in Alaska, has given the FAA and aviation industry an opportunity, through the use of newer technologies, to overcome some of these challenges. One example is in the use of the Automatic Dependent Surveillance-Broadcast (ADS-B) technology to provide "radar-like" air traffic services in traditionally non-radar areas.

Early in the Capstone development effort, it was envisioned by both FAA and the system users in the Bethel area, that this technology would allow the FAA to install a BRITE-like display in the Bethel FCT. This would give the controllers an aid that would dramatically increase their ability to efficiently manage air traffic arriving and departing the Bethel Airport.

Now that Anchorage Air Route Traffic Control Center (ARTCC) is able to provide radar-like services in the Bethel area, we are seeking support for the installation of a display in Bethel Tower, similar to the D-BRITE display currently used in Tacoma Industrial, Renton, and many other FCT facilities, to aid in the sequencing of arrival aircraft.

3.0 Background

Bethel serves as the transportation, trade, and cultural hub for over 58 smaller communities and native villages. The airport is hampered with marginal weather conditions involving cloud ceilings of less than 1,000 feet Above Ground Level (AGL) and/or visibilities of less than three miles more than 22 percent of the time. With aircraft providing the only means of life support to many of the communities, flight in marginal weather conditions occurs often. Bethel FCT recorded 107,814 aircraft operations during FY93. Less than ten percent of these were touch and go and 5,569 consisted primarily of single engine air taxi aircraft operating in marginal weather conditions requiring Special VFR (SVFR) procedures. Operations at Bethel continue to increase with more than

145,000 being recorded in 2000. Night operations are also on the rise due to a number of VFR airports that are serviced from Bethel, being converted to IFR and enhanced with the addition of stand-alone GPS approaches as a part of the Capstone program.

A few years ago Markair Express operated eight single engine aircraft at Bethel. They completed a study revealing that during a one-year period, 85 days necessitated SVFR operations by their aircraft, resulting in 175 hours of delays. Assuming that these figures are representative of other operators, annual SVFR delays to commercial operators would be over 1,500 hours.

Because of the large number of SVFR operations and the high incidence of marginal weather, a waiver was issued to the standard SVFR rules that allows Bethel FCT and Anchorage ARTCC to provide service to IFR/SVFR users on a first come, first serve basis, as long as IFR aircraft are not delayed to the point that they become reportable delays (15 minutes). This provided some relief for aircraft awaiting SVFR clearances. However, delays are still a significant issue according to recent data compiled and analyzed by University of Alaska, which shows an average delay of 10 1/2 minutes for SVFR departures and arrivals.

Anchorage ARTCC is believed to be a major contributor to these delays. Currently, the control sectors are too large to be displayed on a range suitable for providing the radar service necessary to effectively reduce delays in the Bethel area. Additionally, there is too much activity for the controllers to devote sufficient time to Bethel operations to effectively manage the Class E surface area.

On January 1, 2001, Anchorage ARTCC initiated "radar-like" air traffic control services in western Alaska. This marked the first continuous use of a non-traditional surveillance technology for air traffic control purposes. The primary reason for this effort is to improve aviation safety and efficiency in Alaska, beginning in the Bethel area.

Current procedures result in costly delays for commercial users. A display placed in the Bethel tower cab would aid controllers in visually acquiring traffic, issuing traffic advisories, and sequencing arrival traffic. It would also reduce the coordination currently required between Anchorage ARTCC and Bethel FCT. With the number of ADS-B equipped aircraft expected to operate out of the Bethel airport, this BRITE-like display would greatly enhance the efficiency and safety of the operations during VFR as well as SVFR weather.

The display would be used strictly as an aid for sequencing by the Bethel controllers just as any VFR tower would use a D-BRITE and in accordance with existing Air Traffic policy for VFR towers.

4.0 Preferred Option

There has been much discussion between the FAA Alaskan Region and the system users concerning the delays experienced by SVFR and IFR pilots arriving Bethel. Collectively, we agreed that the following course of action would improve the situation.

a. Re-design the Bethel area control sector at Anchorage ARTCC to enable the controllers to dedicate more time specifically to Bethel Airport operations. Anchorage ARTCC has agreed to a plan that would stratify the existing Bethel sector, creating a high altitude sector to work the aircraft transitioning to and from the Orient and a low-altitude sector to concentrate on the airport traffic at Bethel and the other IFR airports in the Yukon-Kuskokwim Delta. The tentative date for implementation is October 31, 2001.

b. Install a D-BRITE-like display in the Bethel FCT. With the tower currently responsible for control of SVFR aircraft, this equipment will aid in the visual acquisition of aircraft, allowing more efficient arrival sequencing and fewer delays.

One issue of concern inherent to this alternative is that Anchorage ARTCC will not be able to provide radar vectors to final approach at Bethel or any other airport in the low-altitude sector. Limitations in communications coverage and radar display equipment prevent the design of a sector that can be displayed on a range small enough (125 nautical miles) to provide this type of service.

5.0 Alternative

In our continued effort to mitigate these delays we also explored the following alternative. In this option:

a. Anchorage ARTCC would redesign the Bethel area control sectors. As mentioned above, this effort is already in progress with a tentative completion date of October 2001.

b. The responsibility for providing separation and control services to SVFR aircraft would be transferred back to Anchorage ARTCC.

c. A BRITE-like display would be installed in Bethel FCT.

Here are some issues of concern inherent to this option:

i) The sector redesign requires a MEARTS software upgrade in order to stratify the airspace. The modification is expected to be completed in August and the sector redesign in October. Once the redesign is finished, the controller working the low-altitude sector will be able to dedicate more attention to airport traffic, however, it will not give Anchorage ARTCC the capability to provide the level of service necessary to effectively reduce delays.

ii) In order for Anchorage ARTCC to effectively manage the SVFR workload, the establishment of an approach control sector dedicated specifically for Bethel would be required. The sector would need to be

displayed on a range small enough to allow radar vectors for approach sequencing. This configuration however, would not allow it to be combined with adjacent airspace during slower air traffic periods and therefore would require that it be continuously staffed. At this time, Anchorage ARTCC does not have the resources to staff this kind of operation, nor the equipment, (i.e., DSR consoles) to establish such a sector.

iii) If radar-like services expands to SE Alaska, it will likely require another airspace re-design and the establishment of another low-altitude sector. This compounds the previously mentioned resource issues.

iv) Bethel FCT can utilize visual separation rules that are not available to Anchorage ARTCC, allowing them to control aircraft more efficiently.

v) This type of operation increases coordination between Anchorage ARTCC and Bethel FCT, which in turn increases workload and delays. A Letter of Agreement establishing standard procedures may provide some relief in this area.

vi) The re-designed sector, as currently planned, is still quite large and contains several IFR airports. Increases in air traffic activity during marginal weather conditions and as a result of increased utilization of radar-like services, the controllers may be required to devote their time and attention to airports other than Bethel. This would counteract the benefit that this option offers.

vii) The Bethel FCT personnel are more familiar with the visual features of the surrounding area and could provide a better service to the aviation community.

viii) With the DBRITE-like display, the tower would have the means of providing the safest and most efficient service to commercial operators. However, they cannot do this without continuing the responsibility for separation and control of SVFR aircraft as they presently do.

6.0 Recommendation

The controllers at Bethel, with a BRITE-like display installed in the cab would be in a position to provide the most efficient and safest service to the aviation community. The users recognize that this would mean a more efficient operation for them, resulting in less fuel burned and money saved. Anchorage ARTCC recognizes that this equipment in the cab would mean a more efficient operation with respect to the SVFR traffic and less holding and delays for the IFR traffic.

It appears to be in the best interest of all involved to place a display in the FCT to be used as an aid in sequencing aircraft with minimum delays. We recommend a re-evaluation of the current FAA position on this issue.

APPENDIX C
CAPSTONE CONCEPT OF OPERATIONS FOR SOUTHEAST ALASKA
DRAFT April 2001

Overview: An aviation evolution, using satellite based technology, is leading the way to the future for the Federal Aviation Administration (FAA) and the National Airspace System (NAS). Over the next several years, an FAA/Alaskan industry partnership will participate in a practical evaluation of an end to end “mini” NAS change, using Global Positioning System (GPS) information for aircraft flight path position generation, and Data Link technology to connect users and service providers. These changes are driven primarily by injection of an *augmented Global Positioning System (GPS)*. Data from this *highly accurate surveillance and navigation tool enables on board generation and data linking of aircraft flight path and position information. Using Augmented space based navigation* aids in conjunction with existing terrain and traffic avoidance data enhances the pilot’s ability to operate safely in, what is presently, a high-risk environment. These same signals when data-linked between users and service providers allow Air Traffic Control (ATC) to use Automatic Dependent Surveillance technology fused with present day transponders to create a low-cost radar-like environment in areas previously not served. This practical evaluation, known as Capstone, will validate the application and functional capabilities of these technologies and their ability to increase aviation safety and airspace capacity while decreasing the cost of the supporting infrastructure and avionics. To best describe this transition, we will follow a typical “flight through the system” to observe the changes these technologies offer. Technology changes are depicted in *Bold Italics*. Due the large number of acronyms in this document, and to support broad understanding of the contents, each phrase with an associated acronym is spelled out followed by the acronym in parenthesis.

Flight Planning: The pilot, dispatcher, and flight follower begin flight planning with the weather and Notices to Airmen (NOTAMs) for the departure airport, route of flight, and destination airport. Users will also access other information needed during flight planning, such as Special Use Airspace (SUA), system congestion projections etc. There are several means available to obtain them:

- Call 1-800-WX-Brief for a Flight Service Station (FSS) Specialist.
- Use our home or office personal computer to access the Direct User Access Terminal Service (DUATS) or the Internet to view near real-time weather camera photos and other weather products.
- The pilot may activate the aircraft data link system to provide us with weather and other information.

Weather products come from many sources: National Weather Service observers and forecasters, Automated Weather Observing Systems (AWOS), Automated Surface Observation Systems (ASOS), Flight Service Station (FSS) Specialists, or Contract Weather Observers (CWO); Supplemental Aviation Weather Reporting Services (SWARS), or affiliated weather reporting stations. Each source becomes a candidate

for *data linking to aircraft* as well as being provided over the *internet*. Each flight planner also searches Notice to Airmen (NOTAM) information for any anticipated anomalies in the Automatic Dependent Surveillance-Broadcast (ADS-B) ground sites, *Global Positioning System (GPS) augmentation system*, and the Global Positioning System (GPS) Receiver Autonomous Integrity Monitoring (RAIM), or constellation broadcast signals.

If planning favors a successful flight, we file our flight plan (instrument or visual) using Direct User Access Terminal Service (DUATS), our 1-800-WX-Brief connection, or our data-link connection. We ensure the aircraft specific six-character code appears in the comment section of our flight plan for inclusion into the Air Traffic Control (ATC) system. *We indicate the track designation for each Augmented Global Positioning System enhanced low altitude route* we plan to use during the trip on our flight plan. Air Traffic personnel enter our flight path information into the automation system for use in the *Flight Plan Monitoring system* and for storage in the Air Route Traffic Control Center (ARTCC) automation system.

Dispatchers and flight followers watch data block/targets of their flights progress over a map of their operating area on their Personal Computer (PC) displays. When a flight arrives at its destination, a message is forwarded via the dispatchers data link advising airline personnel of arrival times. The flight is handled the same upon departure. The map depicted on the Personal Computer screen displays the flight's data block as it progresses from the departure airport towards its next destination airport. Airports are also depicted on the map. The flight number and destination airport identifiers are displayed in the data block.

Pre-Flight and Taxi:

We are ready to begin our aircraft preflight. We ensure the aircraft's *avionics* include a functional Terrain *Alerting and Warning System* appropriate for the type of flight planned. We ensure we have Automatic Dependent Surveillance (ADS) for use in areas of radar-like coverage and as a collision avoidance tool. We ensure that Global Positioning System (GPS) is fully functional for all navigational needs and the planned flight path information is programmed into the Primary and Multi-Function flight displays. We check the Flight Information Services (FIS) feature of our data link system. Throughout our flight the data link will acquire weather, Notice to Airmen (NOTAM), Special Use Airspace (SUA), and other supplemental flight information from a Ground Broadcast Transceiver (GBT) and present it, on demand, onto the Multi-Function Display (MFD) unit in the cockpit. Having checked out our aircraft and its avionics systems, we are ready to taxi to the active runway. Upon starting our aircraft and powering up our avionics, our data link will enable us to view the location of other aircraft and specially equipped vehicles in our area. Each aircraft that are transmitting position information from Automatic Dependent Surveillance (ADS), or any

transponder mode to the **Multi Lateration System**, can be seen on our cockpit display. We radio our dispatch, flight follower, or the Flight Service specialist to confirm they are able to **view our position on their Personal Computer (PC) display**. We use the aircraft's data link display to obtain continuous updates to weather information needed for the route to be flown. We contact the control tower or controlling agency for clearance to the movement area. If our flight plan has been properly entered the FAA facility's equipment automatically acquires and tracks **our aircraft on the display**. We taxi to the runway in use using the airport diagram on our display, while we monitor our radio to ensure we are complying with the Air Traffic Control (ATC) clearance and are clear of all traffic. If we are on an uncontrolled airport, we observe the ramp and taxiways for activity, monitor the Common Traffic Advisory Frequency (CTAF), and announce our position and intentions. As we taxi into position on the assigned runway, we select and view the terrain alerting and warning features on the Multi-Function Display (MFD).

En Route:

As we depart, we radio the departure time to Air Traffic Control (ATC) and begin to receive Automatic Dependent Surveillance (ADS) surveillance service. The automation equipment in the facility acquires our aircraft specific identification and tags the target for the controller. Our Multi Function Display (MFD) indicates our route, areas of significant weather and terrain, and other transponder or **Automatic Dependent Surveillance (ADS) traffic** operating in the vicinity. If flying under Instrument Flight Rules (IFR), we already have the route information stored in the on board system database and we begin to receive radar like services based on our aircraft specific **Automatic Dependent Surveillance (ADS)** signal. Using Flight Information Services (FIS), we are able to monitor Notice to Airmen (NOTAMs), weather forecasts, and Special Use Airspace (SUA), information. We can select and view terrain alerts, traffic information, custom sectional map displays, enroute and approach charts, airport information, and access other supplemental text information as the need arises. Terrain alerts and warning presentation on the Multi Functions Display (MFD) and primary flight display help us identify and avoid areas of rising terrain along our flight path. Our displayed traffic target symbols are tagged with the flight identification, present location, speed, altitude, and velocity vectors of other aircraft. This information helps us avoid conflicts and collisions and optimizes airspace capacity. Our aircraft appears on the Multi Function Display (MFD) on other aircraft's panel for use in the same manner by other crews. The ground based controllers, specialist and airline operation personnel continuously monitor and evaluate our aircraft flight path data against other aircraft adding a layer of protection against airborne conflicts. Special Use Airspace (SUA) areas, and areas of significant weather appear on our display. Terrain information can be superimposed on our display to

Arrival:

determine the aircraft's exact relationship to terrain. Along our route, we use ***remote communications outlets*** to relay flight information etc. As we near our destination, we review airport information, current weather and Notice to Airmen (NOTAM) information using the Flight Information Services (FIS) feature on the Multi Function Display (MFD). We also check the display for any traffic operating in our vicinity that cannot be detected visually. Our Automatic Dependent Surveillance (ADS) and transponder continue to report our Global Positioning System (GPS)-based position to the Ground Broadcast Transceiver (GBT) ***or multi lateration*** ground host and to other aircraft in our vicinity. After receiving an instrument approach clearance when flying under instrument rules, we contact the Air Traffic Control (ATC) facility for the airport on the appropriate radio frequency of landing instructions and clearances. At uncontrolled airports, we broadcast our intentions on the Common Traffic Advisory Frequency (CTAF) for those aircraft without the data link. We scan the Multi Function Display (MFD) to detect any unannounced airborne or surface traffic near or on the airport surface. We monitor the topographical information provided on the Multi-Function Display (MFD) to ensure proper terrain clearance is maintained. ***We scan the primary synthetic view and crosscheck the highway in the sky information*** for flight path information to the runway.

Taxi to Parking:

We have cleared the active runway. We contact the Automated Flight Service Station (AFSS) and/or the airline operations center on VHF or data link to report our arrival and end ***our flight plan monitoring***. During taxi we monitor the airport diagram on our Multi Function Display (MFD) to ensure compliance with instructions and to locate parking.

The pilot, dispatcher, flight following side

Pilots, Flight Followers, and Dispatchers

The safety of any flight operation is very important to the pilot, his passengers and cargo and is equally important to the dispatcher who helped plan the operation and who will be flight following. The Capstone equipment will improve the safety of operation while providing the pilot and dispatcher additional and much needed information about the flight operations. Valid and timely decisions are easier to make when the greatest amount of information is available to pilots and dispatchers. Pilots will be able to concentrate their efforts on safety of operations when they have a good situational awareness by knowing exactly where they are in relation to terrain, traffic and their destination. ***By blending synthetic vision components into a primary flight display and enhancing the accuracy of terrain and traffic data*** presented on a multifunction display pilot workload is minimized. ***Dispatchers, use the data generated by ADS as an accurate flight-following tool.*** They will be able to follow company flights and advise customers of delays. This will enable airline operation centers to keep people advised of flight progress based on actual aircraft position and movement ***on a Personal***

Computer map display and through communications with the flight crew.

The ATC Side

Along with the user point of view, there are *new technologies* that support enhancements to the Air Traffic system.

Flight Service:

The Automated Flight Service Stations (AFSS's) and Flight Service Stations (FSS's) render services to pilots in all phases of flight. Some of the more visible services provided include weather collection, dissemination, and storage in the Weather Message Switching Center Replacement (WMSCR) database. They work closely with the National Weather Service (NWS). The Notice to Airmen (NOTAM) system is maintained by the Notice to Airmen (NOTAM) center with information principally provided by the Automated Flight Service Stations (AFSS) and Flight Service Stations (FSS's) community. Special Use Airspace (SUA) status information is also provided to enhance the safety of flight.

Automation displays will be linked with other displays throughout the Air Traffic Control (ATC) system, allowing the Automated Flight Service Stations (AFSS's) and Flight Service Stations (FSS's) to obtain information from and make information available to other facilities.

Specialists will monitor the flight progress of participating aircraft for search and rescue purposes, allowing quick response to downed aircraft.

The Automatic Dependent Surveillance-Broadcast (ADS-B) or transponder signal will be used to create a database that AFSS/FSS specialists will use to provide the "Flight Plan Monitoring service."

The Automatic Dependent Surveillance-Broadcast (ADS-B) signal is adapted for presentation on a display screen used by the specialist. Each aircraft in the Automatic Dependent Surveillance (ADS) Ground transceiver coverage area is shown along its route of flight. Loss of an aircraft signal would result in the capability of initiating an immediate search.

Terminal

In the Terminal arena, automation displays will be linked with all other automation display options throughout the Air Traffic Control (ATC) system. This will aid them in separation, sequencing and issuing traffic and enable a facility to obtain information and display pertinent data to other facilities within the system. ***In addition to this Up/Down concept of information sharing, Automatic Dependent Surveillance-Broadcast (ADS-B) equipped aircraft will share much of the information available within the Air Traffic Control (ATC) system as well as between other Automatic Dependent Surveillance (ADS) equipped aircraft.*** Items such as flow control, weather, holding information, position of identified aircraft and airport specific data will be available to all service providers within the system. Controllers will have access to the entire database, including active route information and flight plans. Automation displays will depict aircraft, regardless of the source of position information. Multi-lateration, Automatic Dependent Surveillance (ADS), transponder and radar targets will be simultaneously displayed for information and control purposes. This compatibility of displayed data will enable installation and utilization of radar-like services in areas previously void of radar coverage.

En Route:

The Air Route Traffic Control Center needs to provide an improved instrument flight service in Southeast Alaska. Radio coverage will be enhanced to eliminate existing gaps in communications caused by steep mountainous terrain, limited radar capability, and high Minimum Enroute Altitudes (MEA) and Minimum Instrument Altitudes (MIA). The Air Route Traffic Control Center will be capable of displaying a radar-like target of an instrument aircraft on our radar screens from the airport surface environment all the way up to cruise altitude. Instrument departure, approach, and enroute procedures and separation standards will not be tied to conventional navigation aids, allowing more precise navigation, reduced separation standards, and a more useable Instrument Flight Rules (IFR) infrastructure. Finally, radio and data link will provide communication through all phases of instrument flight in SE Alaska.

Summary:

We have concluded our ***“flight through the system”*** and a brief synopsis from each user and service provider. Automatic Dependent Surveillance-Broadcast (ADS-B) and multi-lateration were employed to provide: surveillance in a radar like environment; flight tracking and following for Airline Operations Centers (AOC); and flight plan monitoring by the AFSS for enhance flight locating, surface and airborne collision avoidance tools for pilots and controllers. Our efforts bundle technologies which are driven by augmented Global Position System information and incorporate into Primary and Multi Function Flight displays of certified terrain data for enhanced low altitude navigation, synthetic vision, Highway in The Sky (HITS), traffic avoidance, moving maps and charts and Flight Information Service (FIS). Safety is the paramount element in all of these concepts; however, demonstration of increased capacity and the cost-benefits of deploying new world

technologies are also vital. The final piece, the “Capstone”, bonds government and industry interests to common goals. This joining of public and private objectives strengthens efforts to field proven concepts quickly and promises to improve passenger safety throughout this millennium.

APPENDIX D
ACTION PLAN FOR CAPSTONE PHASE I - BETHEL/Y-K DELTA

See Capstone Website

<http://www.alaska.faa.gov/capstone/docs/docs.htm>

APPENDIX E
ACTION PLAN FOR CAPSTONE PHASE II – JUNEAU/SE ALASKA

See Capstone Website

<http://www.alaska.faa.gov/capstone/docs/docs.htm>