

On the elimination of pulse wave velocity in stroke volume determination from the ultralow-frequency displacement ballistocardiogram

A. G. W. van Brummelen, Ph.D.*

W. R. Scarborough, M.D.**

W. K. T. Josenhans, M.D.***

Utrecht, Netherlands

Many formulas have been derived to determine the stroke volume from the ballistocardiogram (BCG). In the older formulas the displacement record of a high-frequency ballistocardiograph (HF-BCG) was employed as the source of information.⁸ A more recent attempt utilized the low-frequency ballistocardiograph (LF-BCG).⁵ In reality, when the high-frequency ballistocardiograph was used for recording the ballistocardiogram, the computation of stroke volume was based on the acceleration of the "internal" center of gravity; in the case of the low-frequency ballistocardiograph, it was based on motions of the internal center of gravity, which were hybrid mixtures of displacement and velocity. In both cases, the external motions were "impure" and distorted representations of the "true" internal driving mass-motions.

The formulas used to derive the stroke volume from tracings from the high-frequency (Starr) bed involved a square root relationship between quantities measured from the BCG and the stroke volume. However, it turned out that the statistically

determined exponent was between 1 and 2, and only somewhat closer to 2 than to 1.

In the course of the development of ballistocardiographic systems it has become clear that the ultralow-frequency (ULF) instrument is superior to the other types of ballistocardiographs, for a number of reasons, among which is the ease with which displacement curves can be obtained. It is only logical, therefore, that the modern approach in computing stroke volume, or a quantity proportional to it, from the ballistocardiogram utilizes the ULF instrument only. The most logical attempt to derive information about stroke volume would seem to make use of the displacement record, since this curve represents the shift in the body's center of gravity caused by the ejection of blood from the heart with each systole. Therefore, attention has recently been focused on the displacement record.^{1,3,6,7} Since there was no strong evidence that quadratic relationships should be assumed, every investigator has started with the assumption that the system is a linear one.

Fig. 1 shows a drawing of the displace-

From the Fysisch Laboratorium, Rijksuniversiteit, Utrecht, Netherlands.

This study was supported in part by the Canadian Heart Foundation, Grant X67B.

Received for publication May 6, 1963.

*Department of Medical Physics, University of Utrecht, Utrecht, Netherlands.

**Cardiovascular Branch, Georgetown Clinical Research Institute, Aviation Medical Service, Federal Aviation Agency, Washington, D.C.

***Department of Physiology, Dalhousie University, Halifax, Nova Scotia, Canada.

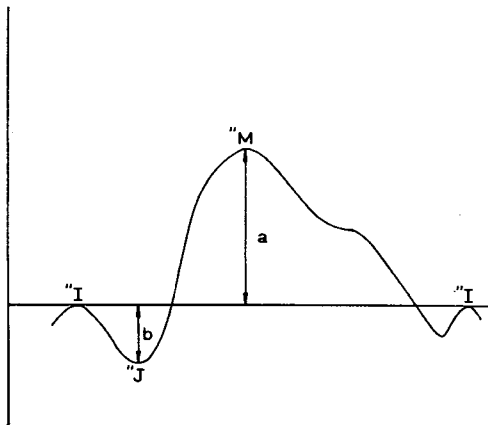

Fig. 1. Schematic representation of an ultralow-frequency displacement record.

ment record of a normal person. Haas,¹ in his formula for stroke volume, used the amplitude of the "J-peak (*b*). However, Klensch³ utilized the amplitude of the "M-peak (*a*). Rödenbeck's approach⁷ is distinctly different from that used by Haas and Klensch. The latter use information drawn from the systolic part of the BCG, whereas Rödenbeck uses only information from the diastolic part. Our preliminary attempts to apply Rödenbeck's formula on model experiments were unsuccessful because of the difficulty of drawing a straight line through the diastolic part of

the curve. Thus far, only Klensch's formula⁴ has been applied to the records from human subjects, and he found good agreement with stroke volume as determined with the Fick method in normal young subjects under "normal" conditions. In patients, however, "normal" conditions may or may not exist; heart rate, peripheral resistance, systolic ejection time, and pulse wave velocity, for instance, may be quite different from normal.¹⁰ A reliable formula for stroke volume requires either that the results be independent of these quantities or there must be a correction in the formula that allows for a change in these quantities.

Until now this problem has not been clarified. It is, of course, a very complicated one, and it can hardly be expected that all these difficulties can be solved at the same time. Therefore, this investigation was begun by singling out one variable—in this case, pulse wave velocity—and evaluating its effect while keeping the other ones constant. In order to accomplish this aim, we decided to use a hydrodynamic model of the circulatory system, taking for granted the shortcomings of such a model.

Methods

The model used in this work was developed by one of us² and is shown in Fig. 2. It is mounted as a whole on a Schwarzer

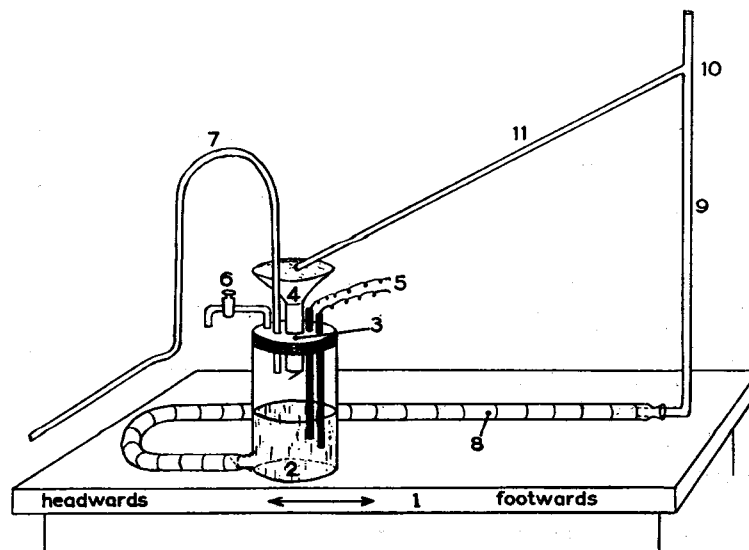

Fig. 2. Hydraulic circulatory pump.

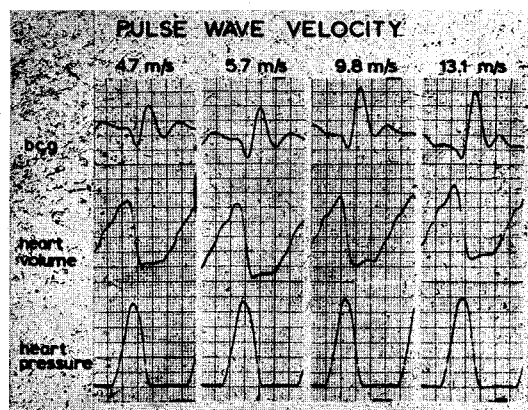

Fig. 3. Samples of displacement "ballistocardiograms," volume curves of the "heart," and "ventricular" pressures recorded simultaneously using the hydraulic circulatory analog. The stroke volume is about the same for the different pulse wave velocities. Calibrations: 0.1 mm. of BCG table deflection equals 13.8 small blocks in the records; 1 cm.³ of change in ventricular volume equals 1.07 small blocks; 100 mm. Hg equals 27.8 small blocks. Heavy vertical time lines are 0.2 second apart.

ULF-BCG (1 in Fig. 2), in such a way that the relative movement between model and BCG is negligible. It consists of a 1-liter cylindrical glass jar (2) covered by a rubber stopper (3) with perforations for a funnel (4), two carbon rods (5), a pressure release tube with stopcock (6), and an air pressure line (7). The glass jar has a 1 3/4-inch outlet low on one side for the dual purpose of (a) connecting the 1 3/4-inch Gooch tube (aorta, 8) to the heart, and (b) housing a low-resistance rubber outflow valve (the "aortic valve"). The 1 3/4-inch Gooch rubber tube* is laid out in a fashion similar to that of the aorta, with a shorter ascending and a lower descending branch. The end of the Gooch tube is connected to a 100-cm. long vertical glass tube (9) with an open end (10) to prevent syphoning in the backflow tube (11). The funnel (4) collects the returning water. Between the funnel and jar is a low-pressure valve ("atrioventricular valve"). The electrical resistance between the carbon rods (5) alters with the level of fluid in the jar (2) and thus allows one to record the time course of the volume. The ejection of the fluid (myocardial contraction) is

*Canlab catalogue, 1963: No. 74-983.

achieved by an air-pressure-operated truck windshield wiper which opens and closes two gas taps. One tap operates the air pressure, and the other releases the air pressure in the jar. By arranging the opening and closing times of the two taps and tap 6 in Fig. 2, one can obtain a wide variation of pressure contours and pressure maxima. For this study a bell-shaped pressure contour, beginning and ending at 0 pressure, was used. To obtain different pulse wave velocities a number of different colored strings were wound helically around a rubber tube which lies on the BCG in the shape of the aorta. By systematically cutting the strings (first, one string; then two, three, etc.) it was possible to change the pulse wave velocity in the range from 13.1 M. per second downward to 4.7 M. per second in six steps. The volume of the "heart" could be measured as a function of time, which made it possible to calculate the stroke volume. Samples of records are reproduced in Fig. 3. Pulse wave velocity was calculated from the time delay of two pressure curves recorded simultaneously from the beginning and the end of the aorta.

Results

The results are represented in Figs. 4, 5, and 6. In Fig. 4 the amplitude of the "M-peak (a in Klensch's notation) is

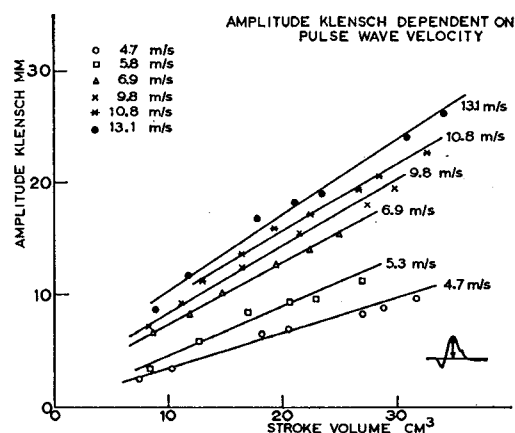

Fig. 4. Relation between the height above the base line of the "M-peak of the BCG (or a) and stroke volume for different pulse wave velocities. Correlation coefficient computed using all points is +0.740. High degree of dependence on pulse wave velocity is apparent.

plotted against "stroke volume"; the correlation coefficient, r , when all measured points are included, was $+0.74$. However, there is a striking dependence on pulse wave velocity when this amplitude measurement is employed, even though a high correlation is present for any single pulse wave velocity.

It has been known for some time that the amplitude of the "J-wave (b) decreases and the "M (a) increases with increasing pulse wave velocity.⁷ This phenomenon was also found in our model experiments (Fig. 3). It seemed logical, therefore, to determine whether some linear combination of these wave amplitudes might not be independent of pulse wave velocity. As a first trial, we intuitively took the linear combination $2b+a$ (or "I" J + "J" M). This combination makes the final results considerably less sensitive to inaccurate placement of the base line than are those calculated from the formula of Klensch,⁴ who uses only a in his formula. As an historical note it should be remarked that Starr¹¹ employed a similar relationship, viz., $2I + J$, in one of his formulas to calculate stroke volume from the HF displacement record.

The results of this combination are given in Fig. 5. There is still some dependence on the pulse wave velocity but much less than in Fig. 4 (correlation coefficient, r , = $+0.989$). A different linear combination derived statistically from analog computer measurements shows even less effect of the pulse wave velocity. Using the method of the least squares, and assuming a linear relationship, the coefficients of b and a were 2.0 and 0.8, respectively. The correlation coefficient was improved accordingly to $+0.994$. A plot using these coefficients is given in Fig. 6. It should be noted here that these results give only the ratio between the coefficients. The calibration factor will be introduced in later studies. Fig. 6 shows that the influence of the pulse wave velocity has been eliminated. Work of a similar nature relating to the other three variables (heart rate, peripheral resistance, systolic ejection time) is now in progress, both in model experiments and in patients.

This work should be looked upon as a starting point, the results of which justify further investigation since an essential variable was eliminated by this method.

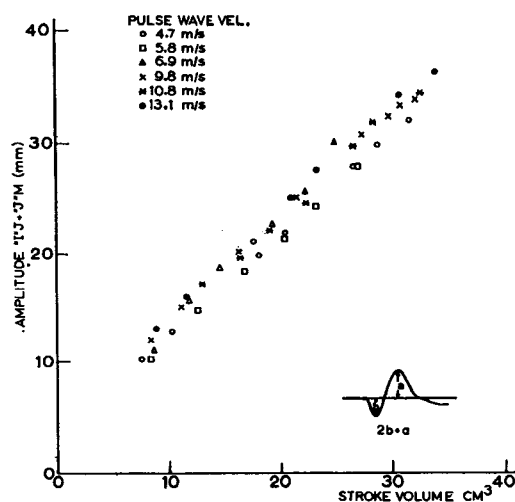

Fig. 5. Relation between the linear combination of the "I" J and "J" M segment amplitudes (or $2b+a$) and stroke volume for different pulse wave velocities. Correlation coefficient is $+0.989$.

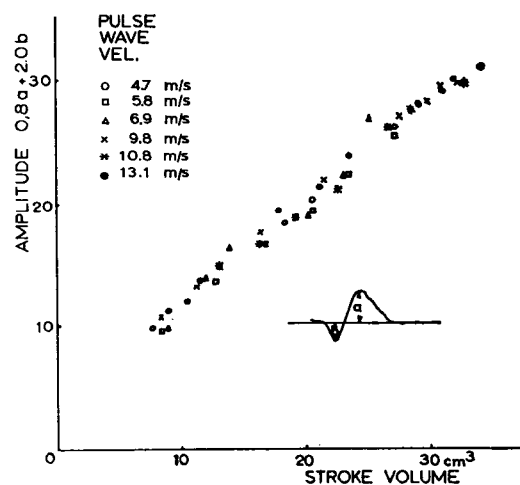

Fig. 6. Same as Fig. 5, but with a different linear combination, $2b+0.8a$. Correlation coefficient is $+0.994$. Dependence on pulse wave velocity is no longer present under these experimental conditions.

However, the very high degree of correlation found in this hydraulic-model work between stroke volume and certain amplitude measurements from ultralow frequency displacement ballistocardiograms should serve to stimulate immediate investigation of this relationship in human beings by the simultaneous measurement of mean stroke volume by indicator-dilution or Fick techniques and displacement bal-

listocardiograms from ultralow-frequency systems; studies of this kind have already begun on a modest scale.

Summary

A hydrodynamic model of the systemic circulatory system was mounted on an ultralow-frequency ballistocardiograph (ULF-BCG). The relationship between stroke volume and ballistocardiographic amplitude was investigated for different pulse wave velocities. It was found that the amplitude of the displacement ballistocardiogram, as used by Klensch ("J" minus "I"), is strongly correlated to stroke volume; however, the relationship is highly dependent on pulse wave velocity. Closer evaluation of the data showed that there is a combination of amplitude measurements that also gives a strong correlation between amplitude and stroke volume but is now independent of pulse wave velocity.

REFERENCES

1. Haas, H. G.: Über ein neues Verfahren der Ballistokardiographie, Thesis, Bonn, 1955.
2. Josenhans, W. K. T.: Experimental analysis of the ultra-low frequency ballistocardiogram by means of a circulation model, Proceedings of the Second European Symposium on Ballistocardiography, Bonn, 1961.
3. Klensch, H., and Eger, W.: Ein neues Verfahren der physikalischen Schlagvolumenbestimmung, *Pflügers Arch.* **263**:459, 1956.
4. Klensch, H., Schade, A., Thurn, P., Caspari, R., and Hilger, N.: Vergleichende Untersuchung des Minutenvolumens des Herzens mit der ballistischen und der direkten Fickschen Methode, *Pflügers Arch.* **269**:232, 1959.
5. Nickerson, J. L.: Estimation of stroke volume by means of the ballistocardiograph, *Am. J. Cardiol.* **2**:642, 1958.
6. Noordergraaf, A.: Physical basis of ballistocardiography, Thesis, Department of Medical Physics, University of Utrecht, Utrecht, Netherlands, 1956.
7. Rödenbeck, M.: Studies on the biophysics of ballistocardiography, Thesis, Leipzig, 1959. U. S. Joint Publications Research Service, Washington, D. C. (available from Dr. Wm. R. Scarborough).
Rödenbeck, M.: Voraussetzungen für die Möglichkeit der Schlagvolumenbestimmung aus dem Ballistocardiogramm, Proceedings of the First Congress of the Society for Ballistocardiographic Research, Zeist, 1960.
Rödenbeck, M.: Grenzen ballistokardiographischer Schlagvolumenbestimmungen, *Ztschr. Kreislaufforsch.* **50**:117, 1961.
8. Starr, I., Rawson, A. J., Schroeder, H. A., and Joseph, N. R.: Studies on the estimation of cardiac output in man, and of abnormalities in cardiac function from the heart's recoil and the blood's impacts; the ballistocardiogram, *Am. J. Physiol.* **127**:1, 1939.
9. Talbot, S. A., and Harrison, W. K.: Dynamic comparison of current ballistocardiographic methods. Part II, *Circulation* **12**:845, 1955.
10. Burger, H. C., and van Brummelen, A. G. W.: Proceedings of the Fourth European Symposium on Ballistocardiography, Lille, 1963 (to be published and edited by Dr. J. F. Merlen).
11. Starr, I.: Studies made by simulating systole at necropsy. VI. Estimation of cardiac stroke volume from the ballistocardiogram, *J. Appl. Physiol.* **8**:315, 1955.

