

Doc
FAA
AM
91
17

FAA/AM-91/17

of Aviation Medicine
Washington, D.C. 20591

Inhalation Toxicology: XII. Comparison of Toxicity Rankings of Six Polymers by Lethality and by Incapacitation in Rats

Donald C. Sanders
Boyd R. Endecott
Arvind K. Chaturvedi

Civil Aeromedical Institute
Federal Aviation Administration
Oklahoma City, Oklahoma

December 1991

Final Report

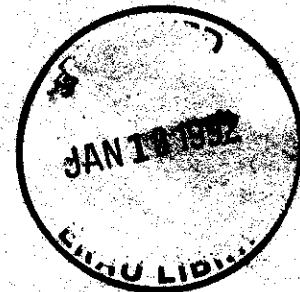

This document is available to the public through
the National Technical Information Service,
Springfield, Virginia 22161.



U.S. Department
of Transportation
**Federal Aviation
Administration**

Doc
FAA
AM
91/17

1. Report No. DOT/FAA/AM-91/17		2. Government Accession No.		3. Recipient's Catalog No.	
4. Title and Subtitle INHALATION TOXICOLOGY: XII. COMPARISON OF TOXICITY RANKINGS OF SIX POLYMERS BY LETHALITY AND BY INCAPACITATION IN RATS				5. Report Date December 1991	
				6. Performing Organization Code	
7. Author(s) Donald C. Sanders, M.S., Boyd R. Endecott, B.S. and Arvind K. Chaturvedi, Ph.D.				8. Performing Organization Report No.	
9. Performing Organization Name and Address FAA Civil Aeromedical Institute P. O. Box 25082 Oklahoma City, OK 73125-5066				10. Work Unit No. (TRAIS)	
				11. Contract or Grant No.	
				13. Type of Report and Period Covered	
12. Sponsoring Agency Name and Address Office of Aviation Medicine Federal Aviation Administration 800 Independence Avenue, SW Washington, DC 20591				14. Sponsoring Agency Code	
15. Supplementary Notes This work was performed under task AM-B-90-TOX-58.					
16. Abstract Polymeric aircraft cabin materials have the potential to produce toxic gases in fires. Lethality (LC ₅₀) in animal models is a standard index to rank polymers on the basis of their combustion product toxicity. However, the use of times-to-incapacitation (t _i s) may be more realistic for predicting relative escape times from a fire environment. Therefore, LC ₅₀ s and t _i s for six pure polymers of different chemical classes were determined and compared. The polymers were polyamide (I), polystyrene (II), Nylon 6/6 (III), polysulfone (IV), polyethylene (V) and chlorinated polyethylene (VI). In the study, male Sprague-Dawley rats (150-250 g), 12 animals per fuel loading, were exposed to the pyrolysis products from selected weights of each polymer for 30 min in a 265-L combustion/exposure system, and LC ₅₀ s were determined following a 14-day observation period. For each polymer, t _i s were also measured at 16 g, that is, 60 mg/L, and at their respective LC ₅₀ s using the inability of rats (n ≥ 12) to walk in rotating cages as a criterion for incapacitation. The LC ₅₀ s (mg/L) of the polymers had the order of I (45.7) < II (56.6) ≈ III (58.1) < IV (63.2) < V (75.5) < VI (87.5), while their t _i s (min) at 16 g (60 mg/L) had the order of III (6.6) ≈ I (7.3) < V (11.7) ≈ II (12.0) < VI (18.4) < IV (21.1). Based on the t _i s (min) at LC ₅₀ s, the polymers were grouped into III & V (10.5, 11.0); I, II & VI (14.1-15.0); and IV (19.5). The two toxicological end points, LC ₅₀ and t _i , did not exhibit the same relative toxic hazard rankings for these polymers. Also, t _i s were not equal at the LC ₅₀ concentrations, a condition of equal lethality. These findings demonstrate the possible involvement of different mechanisms of action for the combustion products of these polymers at the selected end points.					
17. Key Words Inhalation toxicology; aircraft interior polymers; toxicity rankings; lethality; time-to-incapacitation; animal exposure/combustion system; ranking comparison			18. Distribution Statement Document is available to the public through the National Technical Information Service, Springfield, VA 22161		
19. Security Classif. (of this report) Unclassified		20. Security Classif. (of this page) Unclassified		21. No. of Pages 11	22. Price

ACKNOWLEDGEMENT

The authors gratefully acknowledge the invaluable assistance of Mr. James L. Sershon for his expert care and preparation of the animals used in this investigation.

INHALATION TOXICOLOGY: XII. COMPARISON OF TOXICITY RANKINGS OF SIX POLYMERS BY LETHALITY AND BY INCAPACITATION IN RATS

INTRODUCTION

Polymeric materials are used in the construction of aircraft interiors. These materials have the potential to produce toxic gases in a fire involvement; this potential warrants the study of their relative toxicity to allow selection on the basis of safety. One of the commonly used toxicological indices for ranking toxicity of polymeric materials is lethality (Gad, 1990a; N.Y., 1986), generally represented as LC_{50} (amount of a material to produce thermolysis products lethal to 50% of the exposed animals within the defined parameters of exposure and observation periods). The LC_{50} determination includes the immediate, as well as delayed, deaths that occur during the exposure and observation periods of the experiment. Time to physical incapacitation (Crane et al, 1977; Spurgeon et al, 1979), shock avoidance (Hartung et al, 1977), respiration rate depression (Alarie et al, 1981), and hind leg flexion (Farrar, 1980) are other indices used by

investigators. These indices primarily reflect acute effects of the combustion products and are more applicable to predicting relative escape time from a fire environment. Although several studies have been conducted for relative rankings of polymers by LC_{50} or by time-to-incapacitation (t_i) (Crane et al, 1977; Gad, 1990a; N.Y., 1986; Sanders et al, 1985), little effort has been expended to compare rankings of polymers on the basis of their combustion product toxicity by each of these two end points under identical experimental conditions (Levin et al, 1983). Depending upon the chemistry of a polymer and the mechanism of toxicity of its combustion gases, a polymer may produce acute and/or delayed toxic effects. Therefore, the selection of an end point should be associated with the intended use of the resultant rankings.

Earlier studies in our laboratory illustrated that ranking the relative toxic hazard of materials using t_i as the end point produces a rank-order different from that based on time-to-death as a criterion (Crane et al,

Table 1. Chemical Units and Possible Combustion Gases of Polymers

Name	Polymer Chemical Unit ^a	Primary Toxic Gas(es) Produced ^b
Nylon 6/6	$[-NH(CH_2)_6NHCO(CH_2)_4CO-]_n$	CO, HCN
Polyamide	$[-NH(CH_2)_nNHCO(CH_2)_nCO-]_n$	CO, HCN
Polyethylene	$(-CH_2CH_2-)_n$	CO
Polystyrene	$[-CH_2CH(C_6H_5)-]_n$	CO, C_6H_6
Chlorinated Polyethylene ...	$(-CH_2CH_2-)_n$; (Cl = 40%)	CO, HCl
Polysulfone	$[-C_6H_4-4-C(CH_2)_2C_6H_4-4-OC_6H_4-4-SO_2C_6H_4-4-O-]_n$	CO, SO_2

^aFrom Fenner (1975), Harper (1975), and Aldrich Chemical Company, Inc. (Milwaukee, WI) 1990-1991 Catalog/ Handbook of Fine Chemicals.

^bGases indicated are based on the chemical units of polymers. The references for the production of some of the gases are given in the introduction section of the text.

1977). Irritant gases such as hydrogen chloride (HCl) and acrolein, which can produce prolonged deleterious effects on the respiratory tract (Amdur, 1986; Gad, 1990b; Stavert et al, 1991), may inflict damage leading to delayed death even when incapacitation does not occur during exposure (Crane et al, 1985; Gad, 1990a; Kaplan et al, 1985). The combined effects of mixtures of irritant gases and systemic toxicants from burning polymers further complicate an appropriate end point selection (Crane et al, 1977, 1990; Gad, 1990a; Kaplan et al, 1985), making the interpretation of material "rankings" difficult.

Our continuing interest in combustion toxicology prompted us to compare the relative toxicity rankings for six polymers selected from different chemical classes. This selection was to represent a spectrum of common aircraft polymers with the potential to generate different combustion gas(es) capable of causing acute to delayed toxic effects. Names, chemical units and possible primary toxic gases of these polymers are given in Table 1. The selected polymers were individually decomposed under identical experimental conditions and ranked using the LC_{50} s and t_i values (at a fixed sample weight) as criteria. Additional rats were exposed to combustion products from each polymer at its LC_{50} fuel load to determine t_i at this defined condition of equal lethality.

MATERIALS AND METHODS

Polymer Selection

Nylon 6/6, polyamide resin, polyethylene (high density), polystyrene, chlorinated polyethylene (40% chlorine content), and polysulfone resin were obtained from Aldrich Chemical Company, Inc. (Milwaukee, WI); their respective catalog/lot numbers were correspondingly 18,112-9/04, 19,105-1/04642BV, 18,190-0/05, 18,242-7/10, 18,194-3/03691CW, and 18,244-3/06. Polymers did not contain pigments or fire retardants. Pure polymers were used to ensure uniformity of sample composition and were purchased in sufficient quantities to allow the entire study to be conducted using the same batch lots for individual polymers.

Specific polymers were selected to provide as broad a range of gas compositions as possible while still relating to polymers used in aircraft. Polyethylene is a primary carbon monoxide (CO) producer (Spurgeon et al, 1977), while Nylon 6/6 (Terrill et al, 1978) and polyamide (Spurgeon et al, 1977) are known to generate CO and hydrogen cyanide (HCN). Polystyrene is a polymer with a benzene ring in its structure (Harper, 1975) and has the potential to produce CO, benzene,

and heavy black smoke containing finely divided carbon particles. In addition to CO, chlorinated polyethylene and polysulfone can produce HCl and sulfur dioxide (SO_2), respectively (Terrill et al, 1978).

Animals

Male Sprague-Dawley rats (100-120 g) were supplied by Charles River Breeding Laboratories (Wilmington, MA). On receipt, all rats were inspected by a veterinarian and were housed, four to six per cage, in stainless steel cages with mesh-wire floors (27 cm H x 45 cm W x 61 cm L) in the centralized animal facility of the Institute. The facility was maintained at 22-24°C with a relative humidity of 40-60% and a 12-hr light (7 a.m.-7 p.m.)-dark (7 p.m.-7 a.m.) cycle using fluorescent lights. Animals were allowed food and water *ad libitum*. Rats were held in isolation for ten days before use and were fasted overnight prior to the exposure to the polymeric combustion products. Individual animal weights were determined immediately before the experiments; the weight range at use was 150-250 g.

Combustion/Exposure System

The combustion/exposure system used in the study is shown schematically in Figure 1. It consisted of three primary components: a combustion unit, an animal chamber, and a mixing/cooling plenum.

The combustion unit was constructed from stainless steel with a triangular cross section; full length quartz windows in the side of the unit allowed radiant heat from four 2,000-watt quartz lamps (two on each side) to impinge on the sample surface at approximately 45° angles. The unit, designed by H. W. Stacy in the laboratories of Weyerhaeuser Company (Longview, WA), was modified in our laboratory to allow air circulation around the sample. This modification minimized anaerobic pyrolysis and decreased smoke buildup within the unit that would cause a reduction in heat flux at the sample position. A hot-wire igniter was suspended 1 cm above the sample position to ignite the evolved gases. The polymer-test sample was contained in a 7.6 cm X 22.9 cm stainless steel combustion boat.

The animal chamber was constructed from polymethylmethacrylate (PMMA) with an internal volume of 203 L. Mixing/cooling of the combustion gases took place in a 42-L plenum, constructed from polycarbonate, positioned at the end of the animal chamber and over the combustion unit. This plenum was connected to the animal chamber by two 7-cm PMMA intake and exit tubes. The cooled gases were

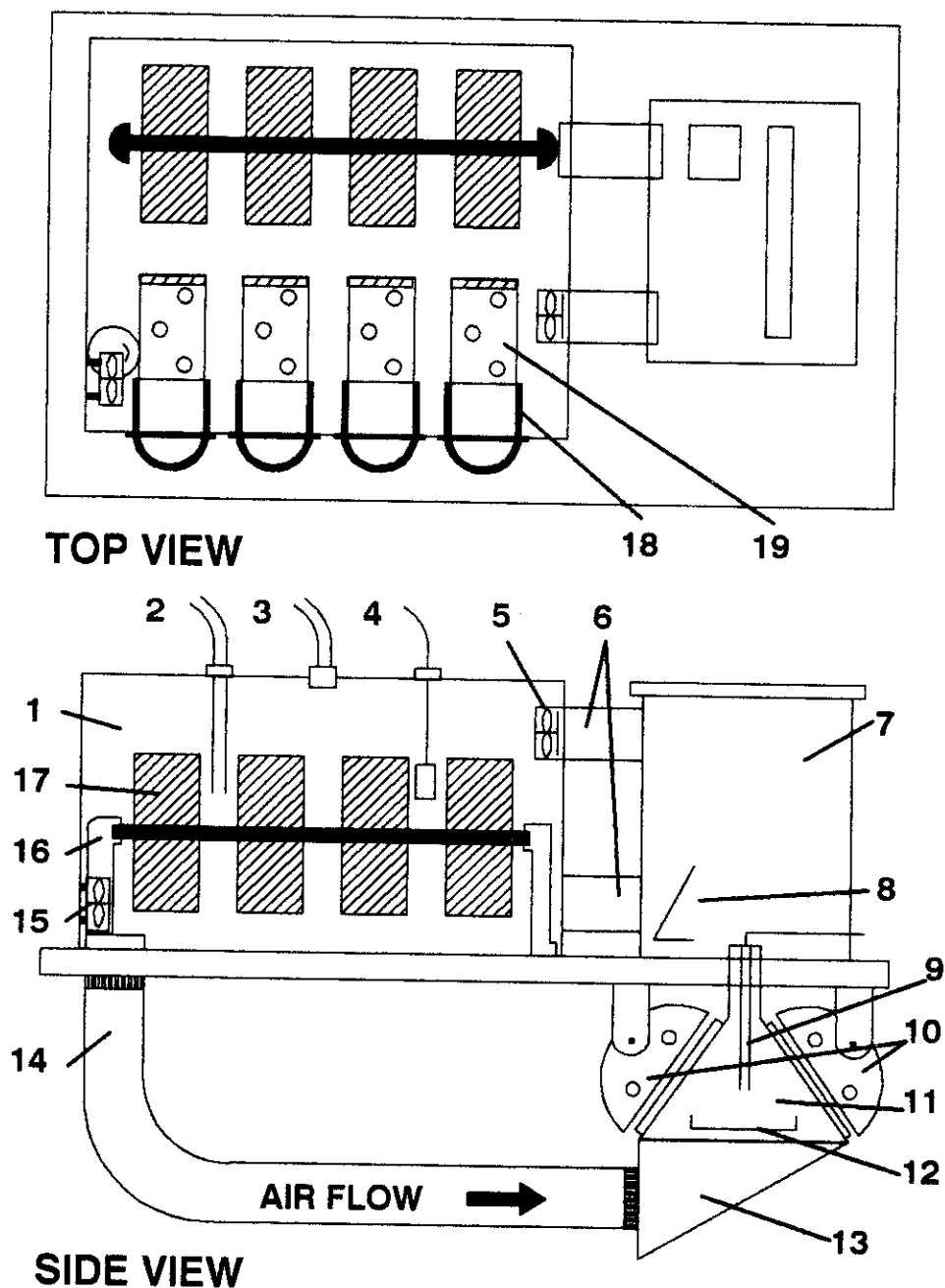

Fig. 1. Schematic Drawing of Combustion/Exposure System.

1. Animal Exposure Chamber; 2. Gas Sampling Inlet; 3. Oxygen Inlet; 4. Thermocouple (air temperature); 5. Muffin Fan (recirculation assembly); 6. Chamber Connecting Tubes; 7. Mixing/Cooling Plenum; 8. Gas Deflector; 9. Hot Wire Igniter; 10. Heat Lamp Reflectors (with two 2,000-watt quartz lamps each); 11. Sample Combustion Unit; 12. Sample Combustion Boat; 13. Combustion Chamber Air Plenum; 14. Flexible Air Recirculation Tube; 15. Muffin Fan (chamber air mixing); 16. Cage Motor Drive Shaft; 17. Individual Rotating Cage; 18. Insert Cage Sleeve (self-closing); 19. Individual Rat Insert Cage

driven into the animal chamber by a box fan attached to the intake tube. A flexible tube between the floor of the chamber and the bottom of the combustion unit provided controlled recirculation of the chamber air around the test sample, into the plenum, and back into the animal chamber. Internal volume of the entire combustion/exposure system was 265 L.

There were four self-closing ports in the animal chamber wall. These ports were used for the rapid insertion (or removal) of individual cylindrical PMMA insert cages at the beginning (or end) of the defined exposure period. Each insert cage of 8.3 cm in internal diameter and of 27.9 cm in length had a removable screen at the chamber end and 48 1.3-cm holes in the cage surface to allow the diffusion of combustion products. Inside the chamber, there were also four 30-cm-diameter rotating cages covered with polypropylene screens. All rotating cages were mounted on a motor-driven shaft, and their perimeter speed (and required walking speed for the rats) was 6.4 cm/sec. In use, the animal chamber body was fitted over the cages, and the system was sealed against a gasket embedded in the chamber base. Animals were contained in the insert cages for the LC_{50} studies and in the rotating cages for the t_i determinations.

Determination of LC_{50} s

One rat was placed in each of the four insert cages, which were then inserted into the chamber through the self-closing ports. A weighed sample of the selected polymer was placed in the sample boat, and the entire system was sealed. Oxygen resupply, gas sampling, and temperature monitoring devices were connected, and the power setting control for the radiant heat assembly was set at mark 55 to supply the desired incident heat flux level. This setting was a compromise between an output that would adequately decompose the sample during a 10-min heating period and a physiological requirement for maintaining the chamber temperature below 35°C (Crane and Sanders, 1986). The heat flux at the sample position increased from 4.0 watts/cm² at 10 sec after initiation to 5.2 watts/cm² at 10 min; external room temperature was maintained at 16°C to further control the animal chamber temperature.

At zero time, the heater power supply, recirculating fans, timer, and hot wire igniter were activated simultaneously. The polymer sample was observed for the first indication of decomposition (melting, smoke) and for the time of ignition. Oxygen was resupplied manually when gas chromatographic analysis (at 1.5-min intervals) indicated a decrease below the ambient concentration (21% v/v). The power to the radiant

heat assembly was turned off at 10 min. From the zero time, animals were exposed to the combustion products for 30 min. Initial exposures for the LC_{50} determinations began at the 16-g level (60 mg/L) of the polymers, and this level was adjusted upward or downward as needed to obtain lethality between zero and 100%. A minimum of two fractionally lethal levels (16-83%), based on 12 rats each, was obtained for each polymer for the estimation of LC_{50} values. The rats were removed immediately at 30 min; survivors were housed in individual cages and observed for 14 days, at which time total mortality in each group was recorded. The LC_{50} values are expressed in mg/L and were calculated by dividing the initial sample weight of the polymer by the internal volume (265 L) of the system. Accordingly, the 16-g sample is equivalent to 60 mg/L.

Determination of t_i s at a Fixed Weight of Polymers

Sample combustion procedures were identical for the t_i studies, except that one rat was placed in each of the four rotating cages. A weighed sample (16 g) of the selected polymer was placed in the sample boat, and the entire system was sealed. At zero time, the cage rotation motor, heater power supply, recirculating fans, timer, and hot wire igniter were activated simultaneously. As described in the LC_{50} determination, the polymer sample was observed for the first indication of decomposition and for the time of ignition; oxygen was resupplied manually when a decrease below the ambient concentration was indicated by the gas analysis. The power to the radiant heat assembly was turned off at 10 min. Time-to-incapacitation (t_i) was recorded (from zero time) when each rat could no longer walk in the rotating cage, that is, when the rat would begin to slide or tumble. When all rats were incapacitated, cage rotation was stopped, the assembly atmosphere was exhausted into a fume hood, and the animals were removed. At least 12 rats were exposed, four at a time, to obtain the mean t_i for each polymer.

Determination of t_i s at LC_{50} s of Polymers

Incapacitation times (t_i s) were also determined for each polymer at the sample weights corresponding to their calculated LC_{50} values, that is, at a condition where the combustion products from each of the six polymers exhibited equal lethality. Twelve rats were exposed to the LC_{50} concentration for each polymer using the same procedure described for the 16-g (60 mg/L) t_i exposure.

Table 2. Toxicity Ranking for Polymers by their LC₅₀ Values

Polymer	LC ₅₀ (mg/L)
Polyamide	45.7
Polystyrene	56.6
Nylon 6/6	58.1
Polysulfone	63.2
Polyethylene	75.5
Chlorinated Polyethylene	87.5

Table 3. Times-to-Incapacitation (t_i) for Rats Exposed to Combustion Products from Polymers at a Fixed Weight of 16 g (60 mg/L)

Polymer	t _i (min) ^a Mean ± S.D.
Nylon 6/6	6.6 ± 1.01*
Polyamide	7.3 ± 0.37*
Polyethylene	11.7 ± 1.30 [‡]
Polystyrene	12.0 ± 0.99 [‡]
Chlorinated Polyethylene	18.4 ± 1.69 [‡]
Polysulfone	21.1 ± 1.83 [‡]

^aMean t_i values denoted with the same symbol are not significantly different from each other. However, t_is are different from other t_i values marked with the different symbol, at p ≤ 0.05 by Duncan's multiple-range test.

Table 4. Times-to-Incapacitation (t_i) for Rats Exposed to Combustion Products from Polymers at their Respective LC₅₀ Fuel Loads

Polymer	t _i (min) ^a Mean ± S.D.
Nylon 6/6	10.5 ± 2.23*
Polyethylene	11.0 ± 0.87*
Polystyrene	14.1 ± 1.59 [‡]
Chlorinated Polyethylene	14.6 ± 1.03 [‡]
Polyamide	15.0 ± 2.99 [‡]
Polysulfone	19.5 ± 1.05 [‡]

^aMean t_i values denoted with the same symbol are not significantly different from each other, but t_i values are statistically different from other t_i values marked with the different symbol (p ≤ 0.05).

Statistical Analysis

Estimation of the LC₅₀s was accomplished using a program translated from Applesoft Basic (Lieberman, 1983) to IBM Basic containing a probit transformation (Finney, 1971). All t_i related data were analyzed at α = 0.05 using analysis of variance and Duncan's multiple-range test for statistical pairwise differences between the groups (SAS/STAT, 1988); values are presented as the mean ± S.D. (n ≥ 12) and a difference between two means was considered significant at p ≤ 0.05.

RESULTS AND DISCUSSION

On the basis of calculated LC₅₀ values, the six polymers were ranked in the decreasing order of their toxicity as: polyamide > polystyrene ≈ Nylon 6/6 > polysulfone > polyethylene > chlorinated polyethylene (Table 2). The most toxic polymer in the series was polyamide (smallest LC₅₀), while chlorinated polyethylene was the least toxic (largest LC₅₀). In general, polymers containing C, H, N, and/or O with the potential to primarily generate CO and/or HCN exhibited acute effects, while polymers that also contained Cl or S produced delayed effects, possibly by the generation of HCl or SO₂. All deaths with Nylon 6/6, polyamide, polyethylene, and polystyrene occurred either during the 30-min exposure period or within 5 min post exposure. In contrast, chlorinated polyethylene and polysulfone caused delayed deaths. Four of the 13 deaths for chlorinated polyethylene were noted from 1 hour to 2 days after the exposure, while 11 of the 13 polysulfone deaths occurred from several hours to 14 days post exposure. This trend is consistent with the acute and/or delayed toxicity associated with these gases (Amdur, 1986; Gad, 1990b; Gossel and Bricker, 1984; Smith, 1986).

The ranking of these polymers by t_i at a fixed weight of 16 g (60 mg/L), from most toxic (shortest t_i) to least toxic (longest t_i), is given in Table 3. Their t_i values ranged from 6.6 to 21.1 min. Polyamide and Nylon 6/6 remained near the most toxic level when evaluated by both end-points (Tables 2 & 3). Polyethylene shifted from the next-to-last place (when ranked by LC₅₀) to the middle for t_i ranking. Although chlorinated polyethylene and polysulfone switched their positions in the rankings, both remained at the lower toxicity levels when evaluated by both toxicological indices. The t_i values for the six polymers at their LC₅₀ sample weights ranged

from 10.5 to 19.5 min (Table 4). When the 16-g t_s were compared with those obtained at the LC_{50} sample weight, they all changed in the expected direction, that is, the larger sample weights produced shorter t_s .

Our findings demonstrated that the polymer rankings by LC_{50} and by t_i are different. This could be because of the involvement of different mechanisms of action of pyrolysis products at these end points. Therefore, the toxicity rankings of polymers should be carefully evaluated in terms of the specific end point utilized and its relation to the intended use of such rankings.

SUMMARY AND CONCLUSIONS

In the study the relative rankings of six polymers by two toxicological indices were compared. Laboratory rats were exposed to the combustion products from the polymers (i) at varying polymer weights to determine LC_{50} s, (ii) at a fixed 16-g weight (60 mg/L) of each polymer to determine t_s , and (iii) at the LC_{50} polymer weights determined in (i) to establish the variation in t_i values under the defined condition of equal lethality. All exposures were performed under identical pyrolysis conditions. LC_{50} and t_i end points did not produce the same relative toxic hazard rankings for the polymers. At LC_{50} s, t_i values ranged from 10.5 to 19.5 min, indicating a wide variation in the incapacitating toxicity of these polymers.

Although t_i provides a useful measure of relative time-to-escape when applied to a survival in a fire environment, interpretation should retain the caveat that delayed deaths are possible, even when incapacitation does not occur during the acute exposure. LC_{50} measurements may be preferable when describing the absolute lethality caused by combustion products, but they give little indication of time available for escape, that is, the length of time before incapacitation occurs. Thus, the LC_{50} would appear to be an inappropriate end point for use in addressing the toxic hazard of smoke in terms of the relative time available for escape. The relative toxic hazard rankings for materials by the two end points are not likely to be comparable, and this incomparability is probably due to the involvement of different mechanisms of action for polymeric combustion products at these end points. Therefore, the principal use for the relative toxic rankings should determine which toxicological index is more appropriate.

REFERENCES

- Amdur MO. Air pollutants. In: Klaassen CD, Amdur, MO, Doull J, eds. Casarett and Doull's toxicology - the basic science of poisons, 3rd ed. New York, NY: Macmillan Publishing Company, 1986:801-24.
- Alarie Y, Anderson RC, Stock MF, Dombroske RL, Keller LW, Hayduk LW, Park RE. Toxicity of thermal decomposition products: An attempt to correlate results obtained in small scale with large scale tests. J. Combustion Toxicol. 1981; 8:58-68.
- Crane CR, Sanders DC, Endecott BR, Abbott JK, Smith PW. Inhalation toxicology: I. Design of a small-animal test system. II. Determination of the relative toxic hazards of 75 aircraft cabin materials. Washington, DC: Department of Transportation/Federal Aviation Administration: 1977; Publication no. FAA-AM-77-9. Available from: National Technical Information Service, Springfield, VA 22161. Order #ADA043646/9GI.
- Crane CR, Sanders DC, Endecott BR, Abbott, JK. Inhalation toxicology: IV. Times to incapacitation and death for rats exposed continuously to atmospheric hydrogen chloride gas. Washington, DC: Department of Transportation/Federal Aviation Administration: 1985; Publication no. FAA-AM-85-4. Available from: National Technical Information Service, Springfield, VA 22161. Order #ADA157400.
- Crane CR, Sanders DC. Inhalation toxicology: VIII. Establishing heat tolerance limits for rats and mice subjected to acute exposures at elevated air temperatures. Washington, DC: Department of Transportation/Federal Aviation Administration: 1986; Publication no. DOT/FAA/AM-86/8. Available from: National Technical Information Service, Springfield, VA 22161. Order #ADA173031.
- Crane CR, Sanders DC, Endecott BR. Inhalation toxicology: X. Times to incapacitation for rats exposed continuously to carbon monoxide, acrolein, and to carbon monoxide-acrolein mixtures. Washington, DC: Department of Transportation/Federal Aviation Administration: 1990; Publication no. DOT/FAA/AM-90/15. Available from: National Technical Information Service, Springfield, VA 22161. Order #ADA230639/LP.

- Farrar DG. The effect of the sensory irritant component of a combustion atmosphere derived from Douglas Fir on the leg-flexion avoidance response of the rat. *J. Combustion Toxicol.* 1980; 7:3-22.
- Fenner, OH. Chemical and environmental properties of plastics and elastomers. In: Harper CA, ed. *Handbook of plastics and elastomers*. New York, NY: McGraw-Hill Book Company, 1975:4-1-81.
- Finney DJ. *Probit Analysis*, 3rd ed. Cambridge: Cambridge University Press, 1971.
- Gad SC. Combustion toxicity testing. In: Gad SC, Anderson, RC, eds. *Combustion toxicology*. Boca Raton, FL: CRC Press, 1990a:81-128.
- Gad SC. Basics of inhalation toxicology and heat stress physiology. In: Gad SC, Anderson RC, eds. *Combustion toxicology*. Boca Raton, FL: CRC Press, 1990b:23-62.
- Gossel TA, Bricker JD. Carbon monoxide, cyanides and sulfides. In: *Principles of clinical toxicology*. New York, NY: Raven Press, 1984:84-104.
- Harper CA. Fundamentals of plastics and elastomers. In: Harper CA, ed. *Handbook of plastics and elastomers*. New York, NY: McGraw-Hill Book Company, 1975:1-1-121.
- Hartung R, Ball GL, Boettner EA, Rosenbaum R, Hollingsworth ZR. The performance of rats on a Rotarod during exposure to combustion products of rigid polyurethane foams and wood. *J. Combustion Toxicol.* 1977; 4:506-22.
- Kaplan HL, Grand AF, Switzer, WG, Mitchell, DS, Rogers, WR, Hartzell, GE. Effects of combustion gases on escape performance of the baboon and the rat. *J. Fire Sci.* 1985; 3:228-44.
- Levin BC, Paabo M, Birky MM. An interlaboratory evaluation of the 1980 version of the National Bureau of Standards test method for assessing the acute inhalation toxicity of combustion products. Washington, DC: Department of Commerce/National Bureau of Standards: 1983; Publication no. NBSIR 83-2678. Available from: National Technical Information Service, Springfield, VA 22161. Order #PB83-198093.
- Lieberman HR. Computation of psychophysical thresholds using the probit technique. *Behavior Research Methods & Instrumentation* 1983; 15:446-48.
- N.Y. Article 15, Part 1120, Combustion Toxicity Testing. Uniform Fire Prevention and Building Code Council. Albany, New York: State of New York, Department of State, 1986.
- Sanders DC, Crane CR, Endecott BR. *Inhalation toxicology: V. Evaluation of relative toxicity to rats of thermal decomposition products from two aircraft seat fire-blocking materials*. Washington, DC: Department of Transportation/Federal Aviation Administration: 1985; Publication no. DOT/FAA-AM-86-1. Available from: National Technical Information Service, Springfield, VA 22161. Order #ADA165034.
- SAS/STAT™ User's Guide. Cary, NC: SAS Institute, Inc., 1988.
- Smith RP. Toxic responses of the blood. In: Klaassen CD, Amdur, MO, Doull J, eds. *Casarett and Doull's toxicology - the basic science of poisons*, 3rd ed. New York, NY: Macmillan Publishing Company, 1986:223-44.
- Spurgeon JC, Speitel LC, Feher RE. Thermal decomposition products of aircraft interior materials. Washington, DC: Department of Transportation/Federal Aviation Administration: 1977; Report no. FAA-RD-77-20. Available from: National Technical Information Service, Springfield, VA 22161. Order #ADA039511/1GI.
- Spurgeon JC, Filipczak RA, Feher RE, Sternik SJ. A procedure for electronically monitoring animal response parameters using the rotating wheel. *J. Combustion Toxicol.* 1979; 6:198-207.
- Stavert DM, Archuleta DC, Behr MJ, Lehnert, BE. Relative acute toxicities of hydrogen fluoride, hydrogen chloride, and hydrogen bromide in nose and pseudo-mouth-breathing rats. *Fundam. Appl. Toxicol.* 1991; 16:636-55.
- Terrill JB, Montgomery RR, Reinhardt CF. Toxic gases from fires. *Science* 1978; 200:1343-47.

*U.S.GPO:1991-661-063/40010

- Farrar DG. The effect of the sensory irritant component of a combustion atmosphere derived from Douglas Fir on the leg-flexion avoidance response of the rat. *J. Combustion Toxicol.* 1980; 7:3-22.
- Fenner, OH. Chemical and environmental properties of plastics and elastomers. In: Harper CA, ed. *Handbook of plastics and elastomers*. New York, NY: McGraw-Hill Book Company, 1975:4-1-81.
- Finney DJ. *Probit Analysis*, 3rd ed. Cambridge: Cambridge University Press, 1971.
- Gad SC. Combustion toxicity testing. In: Gad SC, Anderson, RC, eds. *Combustion toxicology*. Boca Raton, FL: CRC Press, 1990a:81-128.
- Gad SC. Basics of inhalation toxicology and heat stress physiology. In: Gad SC, Anderson RC, eds. *Combustion toxicology*. Boca Raton, FL: CRC Press, 1990b:23-62.
- Gossel TA, Bricker JD. Carbon monoxide, cyanides and sulfides. In: *Principles of clinical toxicology*. New York, NY: Raven Press, 1984:84-104.
- Harper CA. Fundamentals of plastics and elastomers. In: Harper CA, ed. *Handbook of plastics and elastomers*. New York, NY: McGraw-Hill Book Company, 1975:1-1-121.
- Hartung R, Ball GL, Boettner EA, Rosenbaum R, Hollingsworth ZR. The performance of rats on a Rotarod during exposure to combustion products of rigid polyurethane foams and wood. *J. Combustion Toxicol.* 1977; 4:506-22.
- Kaplan HL, Grand AF, Switzer, WG, Mitchell, DS, Rogers, WR, Hartzell, GE. Effects of combustion gases on escape performance of the baboon and the rat. *J. Fire Sci.* 1985; 3:228-44.
- Levin BC, Paabo M, Birky MM. An interlaboratory evaluation of the 1980 version of the National Bureau of Standards test method for assessing the acute inhalation toxicity of combustion products. Washington, DC: Department of Commerce/National Bureau of Standards: 1983; Publication no. NBSIR 83-2678. Available from: National Technical Information Service, Springfield, VA 22161. Order #PB83-198093.
- Lieberman HR. Computation of psychophysical thresholds using the probit technique. *Behavior Research Methods & Instrumentation* 1983; 15:446-48.
- N.Y. Article 15, Part 1120, Combustion Toxicity Testing, Uniform Fire Prevention and Building Code Council. Albany, New York: State of New York, Department of State, 1986.
- Sanders DC, Crane CR, Endecott BR. Inhalation toxicology: V. Evaluation of relative toxicity to rats of thermal decomposition products from two aircraft seat fire-blocking materials. Washington, DC: Department of Transportation/Federal Aviation Administration: 1985; Publication no. DOT/FAA-AM-86-1. Available from: National Technical Information Service, Springfield, VA 22161. Order #ADA165034.
- SAS/STAT™ User's Guide. Cary, NC: SAS Institute, Inc., 1988.
- Smith RP. Toxic responses of the blood. In: Klaassen CD, Amdur, MO, Doull J, eds. *Casarett and Doull's toxicology - the basic science of poisons*, 3rd ed. New York, NY: Macmillan Publishing Company, 1986:223-44.
- Spurgeon JC, Speitel LC, Feher RE. Thermal decomposition products of aircraft interior materials. Washington, DC: Department of Transportation/Federal Aviation Administration: 1977; Report no. FAA-RD-77-20. Available from: National Technical Information Service, Springfield, VA 22161. Order #ADA039511/1G1.
- Spurgeon JC, Filipczak RA, Feher RE, Sternik SJ. A procedure for electronically monitoring animal response parameters using the rotating wheel. *J. Combustion Toxicol.* 1979; 6:198-207.
- Stavert DM, Archuleta DC, Behr MJ, Lehnert, BE. Relative acute toxicities of hydrogen fluoride, hydrogen chloride, and hydrogen bromide in nose-and pseudo-mouth-breathing rats. *Fundam. Appl. Toxicol.* 1991; 16:636-55.
- Terrill JB, Montgomery RR, Reinhardt CF. Toxic gases from fires. *Science* 1978; 200:1343-47.

*U.S.GPO:1991-661-063/40010