

Flying Ace Activities

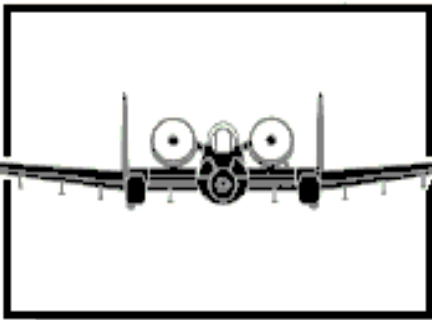
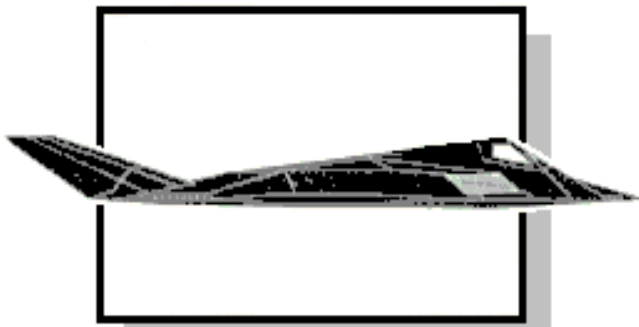

**AVIATION CURRICULUM GUIDE
FOR
MIDDLE GRADE LEVELS 4-6**

Edited by:

Margaret R. Lindman, Ed.D.

Professor

Northeastern Illinois University

Chicago, Illinois

Department of Transportation

Federal Aviation Administration

Office of Human Resources and Management

Washington, D.C. 20591

TABLE OF CONTENTS

Page

ACKNOWLEDGMENTS.....	iii
FAA AVIATION EDUCATION REPRESENTATIVES	iv
STUDY PHOTOGRAPHS	v
SELECTED AEROSPACE TOPICS IN CURRICULUM CONTEXT	x
INTRODUCTION	1
PROPERTIES OF AIR	5
Fluidity.....	6
Weight.....	9
Pressure.....	11
Expansion and Contraction.....	17
Water Vapor/Air Holds Moisture.....	20
Density and Temperature.....	21
Layers of Air.....	22
Measurement of Air.....	23
Movement of Air.....	24
Lift/Resistance.....	25
LIGHTER THAN AIR FLIGHT.....	27
Floating in Air.....	28
Rising Hot Air.....	29
Hot Air Molecules.....	30
Soap Bubble Balloons.....	31
Balloon Flight.....	32
Hot Air Balloon.....	33
Archimedes Principle.....	36
WHAT MAKES AN AIRPLANE FLY.....	37
Newton’s Third Law.....	38
Air Flow.....	40
Gliders.....	42
Parachutes.....	44
Gravity.....	46
Thrust.....	47
Control Surfaces.....	49
Jet Propulsion.....	53

WEATHER IS IMPORTANT TO AVIATION.....	54
Charting Weather	55
Clouds.....	57
Highs and Lows.....	58
The Hygrometer	59
Water/Ice	60
Wind Has Force.....	61
The Anemometer.....	62
Weather Vane.....	63
The Thermometer.....	64
The Aneroid Barometer	65
Dew Point	68
The Sun.....	69
Night, Day, Time Zones.....	70
Heat Energy	72
Color and Temperature.....	73
NAVIGATION IN THE AIR.....	74
The Earth Rotation	75
The Compass.....	76
The Dipping Needle.....	77
Locating Coordinates.....	78
Satellite Signals.....	80
Latitude and Longitude.....	82
The Sextant	84
BIBLIOGRAPHY.....	86
GLOSSARY	99

INTRODUCTION

The Federal Aviation Administration is pleased to present the Aviation Education Teacher's Guide Series. The series includes four publications specifically designed as resources to those interested in aviation education. The guides include activities and lessons specifically designed for use in a variety of content areas at various grade levels. It is our hope that the publications in this series will be beneficial to those who lead America's aviation education initiatives into the 21st century.

ACKNOWLEDGMENTS

The Federal Aviation Administration wishes to recognize and express appreciation to Margaret R. Lindman, Ed.D., Northeastern Illinois University, Chicago, Illinois, for her outstanding leadership and dedication to this project. Dr. Lindman served as chair of Northeastern's Department of Curriculum and Instruction while serving as the leader of the project. Rosamand D. Hilton, formerly of the Chicago Public Schools, served as assistance to Dr. Lindman throughout the project.

Roycealee J. Wood, former Director of Academic Affairs, North Chicago, Illinois, School District #187 served on the project writing committee. Faculty members on the committee included Delores Clark, Dorothy Ashby, Ethyl Booker, Ronald Carlson, William Petrosky, Ann Saunders, and Lawrence Sorenson. We wish to thank each of the teachers in North Chicago School District who participated in the field test phase of the project.

Northeastern Illinois University's FAA Publications Committee members were Harvey Barrett, Ed.D., science educator, Janet Bercik, Ed.D., clinical experiences director and elementary and secondary supervisor; Joanne Frey, Ed.D., elementary specialist; Elizabeth Landerholm, Ed.D., early childhood specialist; Jill Althage and Kristine Tardiff, librarians.

Dr. Gordon Lamb, as President of Northeastern Illinois University, was among those who provided crucial support to this project from the very beginning. The Chicago Teacher's Center, a branch of Northeastern's College of Education and an FAA Aviation Education Resource Center, has contributed substantially to the success of the project.

FAA wishes to especially acknowledge the monumental contributions of Mervin K. Strickler Jr., Ed.D., former Director of FAA's Aviation Education Programs Division. It was Dr. Strickler's leadership that led to the creation of FAA's original FAA Teacher Guides for Aviation Education.

It would have been impossible to complete this project without the professional guidance and assistance of many individuals and organizations. We express our appreciation to the dedicated team who contributed to the earlier editions of the aviation education guides as well as the team completing this edition. Their achievements are admirable.

Phillip S. Woodruff
FAA Headquarters
Aviation Education

Federal Aviation Administration Aviation Education Representatives

Federal Aviation Administration

Phillip S. Woodruff, AHR-15
Zelma P. Thomas, AHR-15
Headquarters
Aviation Education Program
800 Independence Avenue, SW
Washington, DC 20591
(202) 267-3788
(202) 267-3520
(202) 267-9508 fax

Aeronautical Center

Robert L Hoppers, AMC-8
Aviation Education Officer
FAA Mike Monroney Aero. Center
PO Box 25082
Oklahoma City, OK 73125
(405) 954-5332
(405) 954-9964 fax

Technical Center

Carleen Genna-Stoltzlus, ACT-110
FAA, William J. Hughes Technical
Center
Atlantic City, NJ 08405
(609) 485-6630
(609) 485-4391 fax

Center for Management Development

Larry D. Hedman, ANM-040
4500 Palm Coast Parkway, SE
Palm Coast, FL 32137
(904) 446-7126
(904) 446-7200 fax

Alaskan Region

Marsha J. Brown, AAL-4
FAA, Aviation Education Office
222 West 7th Avenue, Box 14
Anchorage, AK 99513-7587
(907) 271-5293
(907) 271-4454 fax
STATE: Alaska

Central Region

Maria Z. Navarro, ACE-41F
601 East 12th Street
Kansas City, MO 64106
(816) 426-6547
(816) 426-3124 fax
STATES: Iowa, Kansas, Missouri,
and Nebraska

Eastern Region

Jim Szakmary, AEA-17
JFK International Airport
Federal Building #111
Jamaica, NY 11430
(718) 995-7999
(718) 995-5663 fax
STATES Delaware, District of
Columbia, Maryland, New Jersey,
New York, Pennsylvania, Virginia,
and West Virginia

Great Lakes Region

Lee Carlson, AGL-11
O'Hare Lake Office Center
2300 East Devon Avenue
Des Plaines, IL 60018
(708) 294-7042
(708) 294-7368 fax
STATES: Illinois, Indiana,
Michigan, Minnesota, North Dakota,
Ohio, South Dakota, and Wisconsin

New England Region

Shelia Bauer, ANE-45
12 New England Executive Park
Burlington, MA 01803
(617) 238-7378
(617) 238-7380 fax
STATES: Connecticut, Maine, New
Hampshire, Rhode Island, Vermont,
and Massachusetts

Northwest Mountain Region

Maurice Caldwell, ANM-14A
1601 Lind Avenue. SW
Renton, WA 98055-4056
(206) 227-2018
(206) 227-2199 fax
STATES: Colorado, Idaho, Montana,
Oregon, Utah, Washington, and
Wyoming

Southern Region

Opal Neeley, ASO-17B.1
1701 Columbia Avenue
College Park, GA 30337
(404) 305-5386
(404) 305-5311 /5312 fax
STATES: Alabama, Florida,
Georgia, Kentucky, Mississippi,
North Carolina, South Carolina,
Tennessee, Puerto Rico, and the
Virgin Islands

Southwest Region

Debra Myers, ASW-18B
Aviation Education Program
Manager
Federal Aviation Administration
Ft. Worth, TX 76193-0018
(817) 222-5833
(817) 222-5950 fax
STATES: Arkansas, Louisiana, New
Mexico, Oklahoma, and Texas

Western-Pacific Region

Hank Verbais, AWP-17F
PO Box 92007
Worldway Postal Center
Los Angeles, CA 90009
(310) 297-0556
(310) 297-0706 fax
STATES: Arizona, California,
Nevada, and Hawaii

BULLETIN BOARD PICTURES

Kites

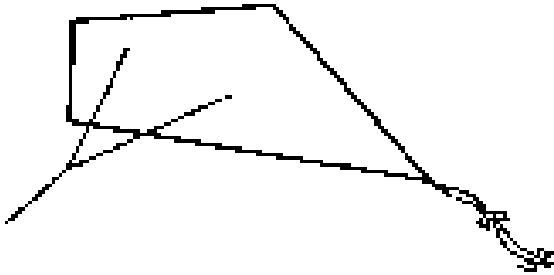

Glider



Blimp

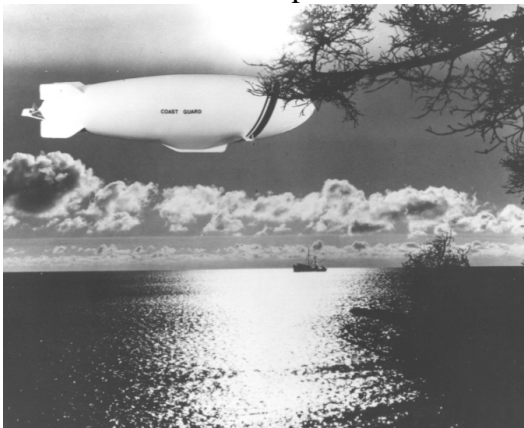

Hot Air Balloon



KITES

Kites are one of the earliest instruments to fly in air. Wind makes kites fly. The wind flows past the kite and creates the force known as lift. Some kites have tails to help them fly smoothly. The tails provide wind resistance which is a force known as drag. Lift and drag are two of the four forces that cause airplanes to fly. In 1899, the Wright brothers took their first step in the invention of the airplane by flying a controlled box kite.

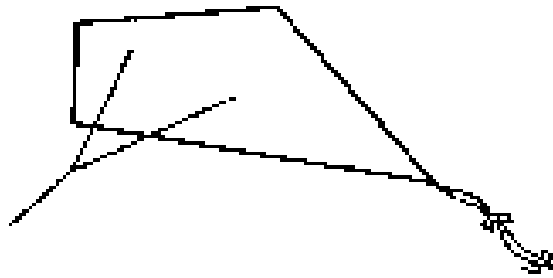

GLIDERS

Gliders are light weight aircraft that do not have an engine. They are towed into the air by another plane or a winch. The glider can gain height by spiraling in currents of rising air called thermals - rising air - and ridge lift - the flow of air rising over a line of hills. Because there is no engine to make noise, the flight is a very quiet one.



BLIMPS

A blimp consists of a huge flexible bag that rises and expands when inflated with helium. Helium is a gas that weights $1/7$ as much as the air around us. Blimps are steered by rudders on their tail fins and engine driven propellers that are attached to the structure.

A passenger cabin is attached at the bottom of the gas bag. This is where the pilots and passengers ride.

Blimps fly slowly and at low altitudes. They are used to taxi sightseers, study the sea, observe the coastline, and for communications and advertising purposes.

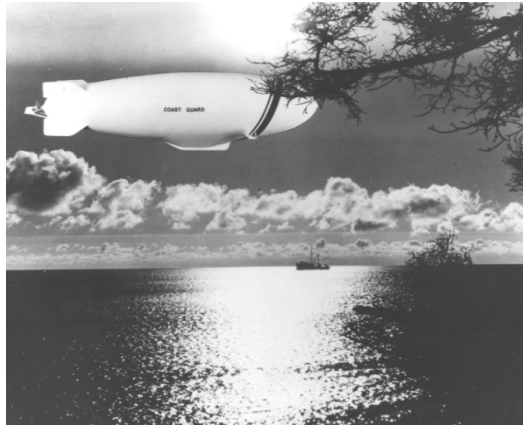

HOT AIR BALLOONS

Hot air balloons consist of a gondola (a basket-like carrier where pilots and passengers ride) attached to a large bag (balloon). Cables attach the balloon and gondola. A burner is attached to the top of the gondola which heats the air inside the balloon. Then the balloon lifts off the ground.

In the gondola are the instruments: the altimeter - measuring distance from the ground; pyrometer - measures air temperature inside the envelope; and variometer - measures speed going up and down; fuel tanks and fire extinguishers are also located in the gondola.



SELECTED AEROSPACE TOPICS IN CURRICULUM CONTEXT

Often educators who teach about aviation and space education are challenged by administrators, other teachers and parents who question the validity of such study. The following list indicates just some of the specific ways this topic interrelates with traditional studies.

Where they fly is GEOGRAPHY

Who made them fly is HISTORY

How they fly is SCIENCE

Where they land is SOCIAL STUDIES

<p style="text-align: center;">ART</p> <p>Balloons Commemorative stamps and medals Da Vinci, Leonardo History of aviation Insignia Interiors of aircraft Kites Medals and decorations Model aircraft Mythology Objects of art Photography Pilot and crew wings Science fiction Trophies and awards</p> <p style="text-align: center;">ASTRONOMY</p> <p>Comets Constellations Eclipse Galaxies Interplanetary travel Light Meteors Moon Observatories Orbiting observatories</p>	<p>Orbits and trajectories Planetariums Planets Solar system Stars Sun Telescopes Universe</p> <p style="text-align: center;">BIOLOGY</p> <p>Animals in space Bird flight Closed ecological system Extraterrestrial life Photosynthesis</p> <p style="text-align: center;">CAREER GUIDANCE</p> <p>Air traffic control Astronauts Charter flying Flight Attendants Flight instruction General aviation Ground service and maintenance Occupations Pilot training Spacecraft design Test pilots Women in aerospace</p>	<p style="text-align: center;">CHEMISTRY</p> <p>Air Atoms Atmosphere Closed ecological system Elements Fuels Gases Propellants Specific gravity</p> <p style="text-align: center;">EARTH SCIENCE</p> <p>Air masses Astronomy Atmosphere Aurora Aviation weather Charts Compasses Earth Environmental research satellites Explorer satellites Geodetic satellites Gravity Greenhouse effect Kosmos satellites Latitude and longitude Lightning</p>	<p>Magnetic course Maps and mapping Meteorology Navigation systems Navigation techniques Orbiting observatories Precipitation Ranger Surveyor Weather Weather maps and charts Weather satellites</p> <p style="text-align: center;">GENERAL SCIENCE</p> <p>Airplane Astronomy Atmosphere Atoms Barometric pressure Bernoulli's principle Bird flight Clouds Electricity Energy Engines Fog Galaxies Helicopters Jet aircraft Launch vehicles</p>	<p>Man in flight Matter Mercury program Photography Planets Radio communications Satellites Saturn rockets Space stations Stars Sun Walk in space Weather Weather satellites</p> <p style="text-align: center;">GEOGRAPHY</p> <p>Charts Compasses Course plotting Latitude and longitude Magnetic course Maps and mapping Photography</p> <p style="text-align: center;">GOVERNMENT</p> <p>Aerospace industry Air traffic control Apollo FAA</p>
---	--	---	---	--

**GOVERNMENT
(Contd.)**

Mercury program
NASA
Pilots and pilot
certificates

HEALTH

Aerospace medicine
Animals in space
Astronauts
Flight physical
Food and nutrition
Life-support systems
Man in flight
Manned spaceflight
Man-powered flight
Pressurization
Spacesuits
Temperature control
Weightlessness

HISTORY

Ace
Autogiros
Balloons
Biographies
Bomber aircraft
Commemorative stamps
and medals
Dirigibles
First World War aircraft
Flying Circus
Gliders
History of aviation
Man-powered flight
Mythology
Science fiction
Second World War
aircraft
Women in aerospace

MATHEMATICS

Binary numbers
Celestial navigation
Course plotting
Dead reckoning
Information systems
Navigation techniques
Orbits and trajectories
Weight and balance

METEOROLOGY

Air
Air masses
Atmosphere
Barometric pressure
Clouds
Convection currents
Earth science
Evaporation and
condensation
Fog
Humidity
Precipitation
Turbulence
Weather maps and charts
Weather satellites
Wind

PHYSICS

Airplane
Airspeed indicator
Attitude control
Automatic landing
Bank
Bernoulli's principle
Boyle's law
Carburetion
Center of gravity
Computers
Electricity
Electronics
Energy
Engines
Gyroscope
Heat energy
Instrument panel
Launching
Matter
Measurement of power
Newton's laws
Noise
Nuclear energy
Nuclear propulsion
Radar
Radio
Robots
Sailplanes
Solar cells
Supersonic flight
Television
Temperature scales
Wind tunnels
Wings

**SOCIAL
STUDIES**

Air forces of the world
Airmail
Air taxis
Apollo
Atlas missile
Biographies
Bombs
Careers
Cargo aircraft
Commercial airlines
Communications
satellites
Crop dusting
Flight (as passenger)
Flight test programs
Forest fire control
Gemini
General aviation
Gliders
Hangars
Helicopters
Heliports
History of aviation
Jet aircraft
Jumbo jets
Kennedy Space Center
Launch facilities
Launch vehicles
Lunar exploration
Manned spaceflight
Manufacturing
Military aircraft
Mythology
NASA
NORAD
Police and fire services
Preflight training
Radio communications
Runways
Sailplanes
Satellites
Search and rescue
Space stations
Unidentified flying
objects
Wind tunnels

INTRODUCTION

Investigation of aviation technology and its related fields leads students to a better understanding of history, present knowledge, and future discoveries. Youngsters need to formulate their own ideas as to design and learning activities through experiments.

Instead of merely telling students that warm air rises, lead them with the question. "Does warm air rise or fall?" Have students answer the question using the scientific method -- identify the problem, observe the situation, conduct an experiment, form a hypothesis and test and confirm (or reject) that hypothesis.

Once students are accustomed to using the scientific method, they will retain more information because they will be actively involved in the learning process. This isn't a new way of teaching. It is simply a fresh look at an age-old method -- the scientific method. Examples of investigation follow.

I. ANSWER THE FOLLOWING SIX QUESTIONS:

What do I want to find out?

What materials do I need?

What should I do with the materials?

What should happen?

What did happen?

Did I find out what I wanted to know?

II SCIENTIFIC METHOD

State problem

List required materials

Outline procedures

Formulate hypothesis

Record observations

Analyze facts

Draw conclusions

III FOR ACTIVITIES AND/OR EXPERIMENTS

Title (or ask a question)

Hypothesis (predict what will happen)

Materials

Procedure

Results and observations

Conclusions (record what you discovered)

NAME _____ DATE _____

SCHOOL _____ ROOM _____

WORKSHEET PLAN OF ACTION

TITLE: _____ EXPERIMENT: _____

SCIENCE PROJECT: _____

STEP 1 PURPOSE: What are we trying to discover?

STEP 2 HYPOTHESIS: What might happen? (question or statement)

STEP 3 MATERIALS: What supplies are needed?

STEP 4 PROCEDURES: How will this be done? (1st, 2nd, 3rd, etc.)

STEP 5 RESULTS: What did happen?

STEP 6 CONCLUSIONS: What was learned?

STEP 7 COMMENTS: How can this experiment be improved?

(Use back of paper to explain)

SUGGESTED STUDENT ACTIVITIES FOR EVALUATION PURPOSES:

1. Students should start a spiral book of experiments. They will follow a format described by the teacher and include dates on all pages.
2. Students should diagram the results of experiments.
3. Students should record results of experiments.
4. Students will develop vocabulary lists.
5. Students will collect pictures from magazines or other places to add to the bulletin board.
6. Students will be encouraged to develop a Science Fair Project. Notebook and note taking will add points to "judging."
7. Students should receive positive reinforcement for any models or homemade projects.

I. PROPERTIES OF AIR

BASIC INFORMATION

AIR

Air is a blending of gases that surround the earth, that are colorless, tasteless, and odorless. Air stretches great distances above the earth. One half of the Air, by mass, is within three and one half miles of the earth's surface. The other half is distributed over hundreds of miles farther. The layer of air enveloping the earth makes life viable. The earth's gravity keeps air from slipping off into space.

AIR WEIGHT AND PRESSURE

The force of gravity holds the air and gives it mass (weight). Air pressure is the measure of the force of air on a specified area. The surface of the earth's air pressure is equal in all directions. Humans do not feel this pressure because their bodies are braced by equal pressure inside them. In the atmosphere, air pressure changes and is measured by barometer. Weather predictions are based on changes in barometric pressure.

AIR PRESSURE

If something as light as a small piece of paper is dropped, it will float slowly to the ground. The paper slows down because of air resistance pushing on the surface area of the paper.

AIR MOTION

Air molecules are moving continuously even though you feel nothing. Great bodies of air are also continuously moving. This is called wind. Air moves because of heat from the sun. The amount of energy from the sun changes constantly and brings about our changing weather conditions.

FLUIDITY

Objective: To demonstrate that air has fluid properties and takes up space.

Materials: Two water glasses, large dish pan filled with tap water, old newspapers to catch water spills.

Procedure: Place one glass into the pan so that it fills with water. Put the second glass into the water upside down so that the air does not escape. Carefully tilt the air-filled glass under the water-filled glass. Air will bubble up in the glass. Practice pouring the air back and forth between the glasses without losing any of the air.

Observations: Do not let the air escape in the second glass. The bubbles will go up and down between the glasses if you do this carefully.

Questions:

1. What makes the bubbles? (Air bubbles flow either up or down into the glasses).
2. What happens to the bubbles? (The bubbles flow either up or down into the glasses.)

Conclusions: Each bubble is a little package of air made visible by being in the water. Air does have fluid properties because it can be poured back and forth.

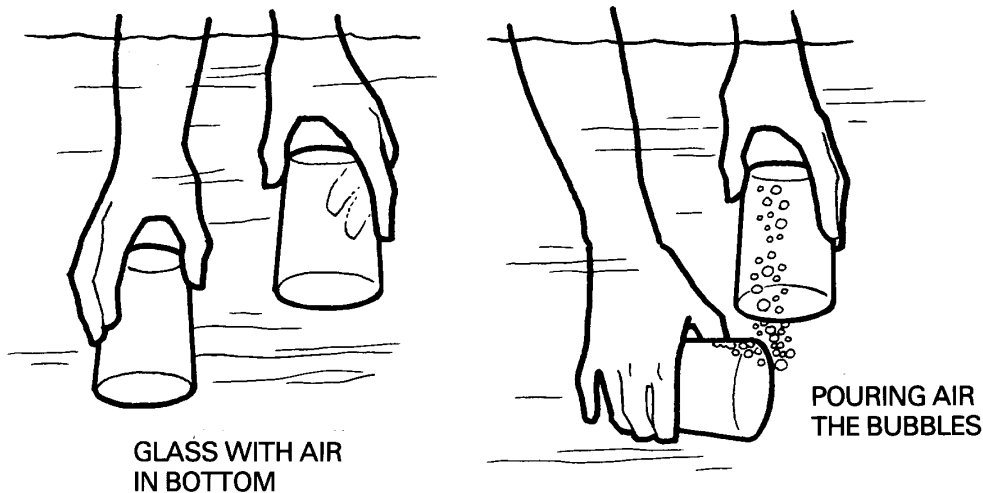

FLUIDITY

Objective: To discover that air has fluid properties and takes up space.

Materials: A glass, dry handkerchief (or tissue), large deep bowl, water.

Procedure: Push the dry handkerchief into the bottom of the glass so that it will not fall out when the glass is turned upside down. Turn the glass upside down and holding it vertically, push the glass into the jar of water until completely covered. Now, lift the glass straight up and out of the water and turn it right side up.

Observations: The handkerchief is completely dry.

Questions: 1. Why isn't the handkerchief wet? (The air took up space and kept the handkerchief from getting wet).

Conclusions: The air inside the glass took up space which is a property of fluid.

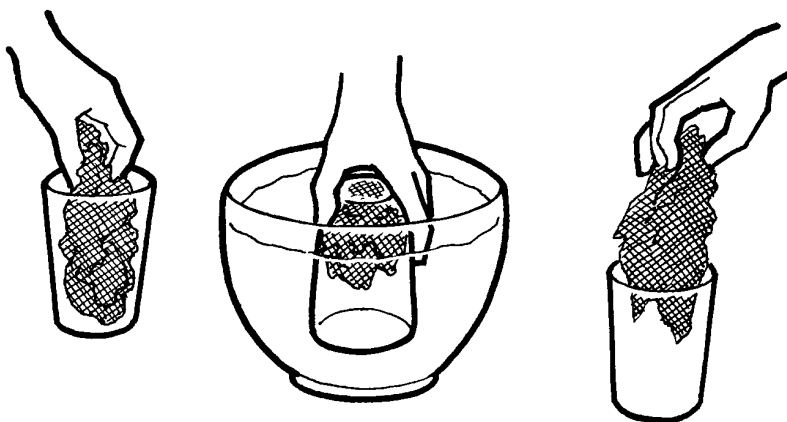

FLUIDITY

Objective: To discover that air has fluid properties and takes up space.

Materials: Clay, funnel, glass or clear plastic jug, water, tooth pick or paper clip that has been straightened.

Procedure: 1. Mold some clay around the neck of a funnel and press the funnel into the mouth of a jug so that an airtight seal is created. (A funnel with its neck in a one-hole stopper may be substituted.) Pour water into the funnel.

Observations: When the water is poured into the funnel the water essentially remains there.

Questions: How does this demonstrate that the jug was not really empty?

2. Take the tooth pick or paper clip and make a small hole in the clay. Listen carefully and watch what happens to the water in the funnel.

Question: Why does the air rush out as the water rushes in?
(Air can be heard to be escaping as the water drains into the jug.)

Conclusions: The air inside the jug took up space and prevented the water from flowing from the funnel into it. Upon making the hole in the clay it was observed that air rushed out of the bottle as water flowed in to replace it.

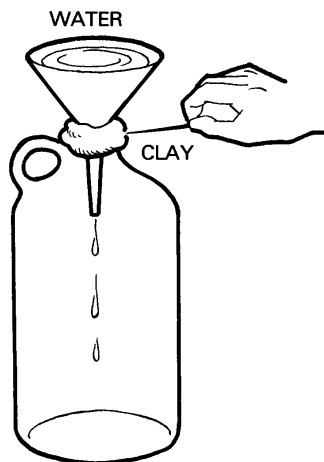

WEIGHT

Objective: To discover that air has weight (mass).

Materials: Balloons of same size, string, scissors, pins, thin dowel rod (about 1 foot long).

Procedure: Blow up two balloons. Tie the necks tightly with string. Tie each end of the string to the dowel rod close to each end. Tie another piece of string to the center of the dowel rod and balance the balloons. Pick one balloon with a pin.

Observations: As the air rushes out of the balloon the stick is no longer balanced. The pricked balloon shoots up and the heavier air-filled one drops down.

Questions:

1. What do you think will happen when we break one balloon? (It should make the remaining balloon go down.)
2. What do you think will happen when we break the other balloon? (This should again balance the dowel rod).
3. How can you explain the results? (The first balloon had all the air go out so this side went up and the other balloon went down because it was heavier).

Conclusions: The balloon that still contains the air falls down because air does have weight (mass).

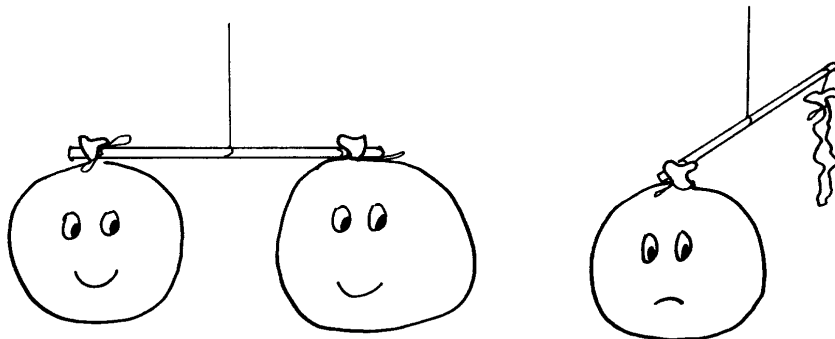

WEIGHT

Objective: To discover that air has weight (mass).

Materials: A yardstick with small holes at the 6, 18, and 24 inch marks, a beach ball or large balloon filled with air, a shallow can (tuna can), sand, a spoon, and some string.

Procedure:

1. Suspend the yardstick by a string attached to the middle hole. You may want to use a window sill, the end of a table, or a rung on a tall chair.
2. Suspend the inflated ball from the 6-inch hole.
3. Hang the small can from the 24-inch hole, as shown in the diagram. If the empty can weighs more than the balloon, hang it closer to the center.
4. Using a teaspoon, fill the can with sand until it just balances the inflated ball.
5. Carefully release all the air from the ball. Watch that the sand does not spill out.

Observations: As the ball deflates, the end of the yardstick with the sand container moves downward toward the floor.

Questions:

1. Why is it important to have the inflated ball and sand container in balance?
2. How does the downward movement of the sand container prove that air has weight?

Conclusions: The ball lost air to the surroundings when it was deflated. The sand container then became heavier than the deflated ball at the opposite end of the yardstick and "went down" in response to the loss of weight.

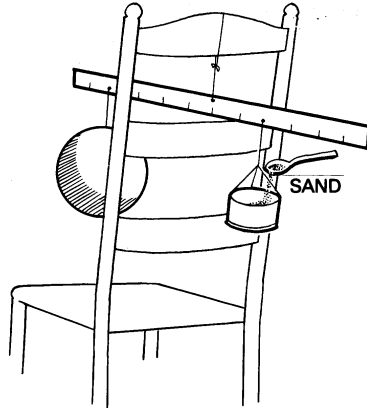

PRESSURE

Objective: To show that air has pressure.

Materials: Bottle or jar with a tight cap, drinking straw, modeling clay.

Procedure: Fill the jar up to the cap with water. Use an awl to punch a hole in the cap and insert the straw. Seal tightly around the straw with the clay. Put the cap on tightly so that no air can get into the bottle. Observe results. Then, release the cap on the bottle just enough to let in some air and try to suck the water through the straw.

Observations: When you let a little air into the bottle, the air pressure is lowered inside the straw. Air pressing on the surface of the water in the bottle pushes it up through the straw as you suck through it.

- Questions:
1. Why didn't the water come up when the cap was on tight? (There was no space inside the bottle for the air to move.)
 2. Did you ever see an elephant in a zoo squirt water? How was it like your straw experiment? (An elephant has a built-in straw, and he puts air pressure to work every time he takes a drink. He puts his trunk in water and breathes in and draws the air out of his trunk. As he does this the water fills his trunk.)

Conclusions: Air pressure that was inside the bottle made it possible to suck up the water.

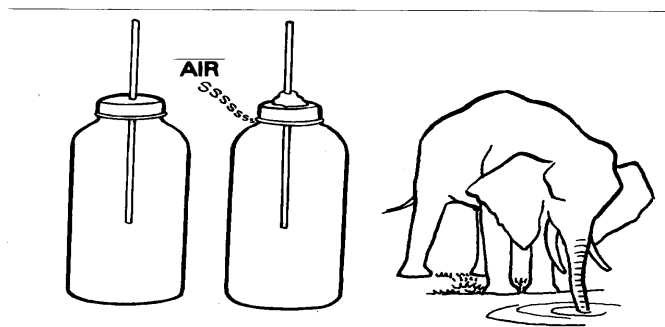

PRESSURE

Objective: To show that air pressure exerts force on our bodies.

Materials: None

Procedure: Slowly take a deep breath, then exhale, slowly.

Observations: Your chest rises when it is filled with air and lowers when you expel some of the air out of your lungs.

- Questions:
1. What happens when you take a deep breath? (The pressure of the inhaled air is transferred by the blood and tissues of the body and holds back the inward pressure of the atmosphere on your body.)
 2. A pilot of a pressurized jet is traveling through the stratosphere where the air is about half the pressure on the earth. What would happen if he were suddenly thrown out of the plane? Why? (The pressure inside his body would be much greater than the outside pressure of the thin air and he would probably burst like an inflated balloon.)

Conclusions: Air pressure does exert force on our bodies.

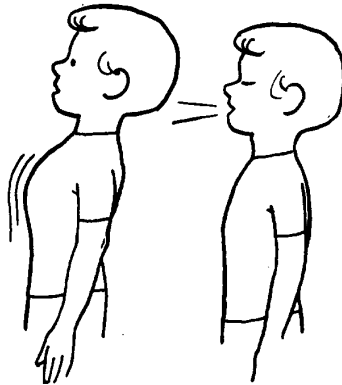

PRESSURE

Objective: To show that air has pressure.

Materials: Water glass, pieces of thin flat cardboard.

Procedure: Fill the glass to the top with water. Place the cardboard over the glass. Holding cardboard tightly to the glass, carefully turn the glass upside down. Remove your hand from the cardboard. The cardboard stays in place against the glass. Tilt the glass or hold it sideways and the cardboard still remains in place.

Observations: The water will leak out if the cardboard is not held tightly when turning the glass over. The cardboard sticks to the glass as it is turned.

Questions:

1. Did the water leak out? Why? (The water leaked out because it was not held tight enough next to the cardboard.)
2. What could you do to keep the cardboard dry longer? (Use thicker cardboard, answers will vary).
3. Did the cardboard stick when the glass was turned sideways? Why? (Yes, the pressure of the air next to the cardboard caused it to hold tight).

Conclusions: The air pressure kept the water from falling out of the cardboard covered glass.

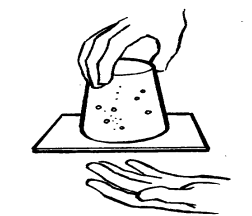

PRESSURE

Objective: To demonstrate changes in air pressure.

Materials: Straight pins, 1" x 1" pieces of cardboard, wooden spool

Procedure: Stick the pin through the piece of cardboard and push the pin through the hole of the spool. Hold the cardboard against the spool. Blow through the opposite end of the spool and let go of the piece of cardboard.

Observations: Blowing into the spool makes the cardboard cling to the spool.

Questions:

1. Why does the cardboard cling to the spool when you blow on it? (The pressure in the air flowing through the hole in the spool and up to the cardboard becomes lower, the pressure on the other side of the cardboard is greater than that inside the hole, therefore, the cardboard clings to the spool)
2. If you blow real hard, the cardboard clings even tighter. Why? (Because the outside pressure is stronger than your breath inside the hole.)

Conclusions: Atmospheric pressure on the bottom of the cardboard is stronger than the pressure inside the spool and holds the cardboard.

(Note: This is an application of Bernoulli's Principle.)

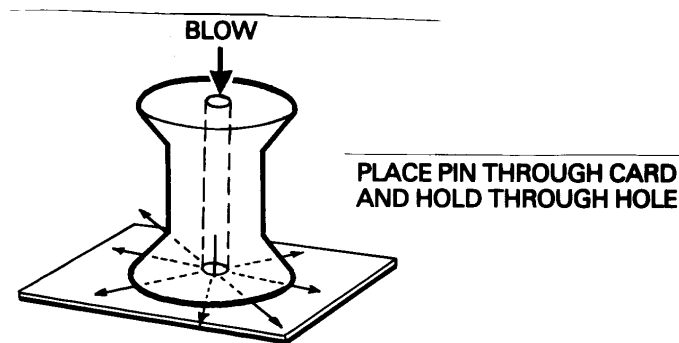

PRESSURE

THIS EXPERIMENT IS FOR DEMONSTRATION ONLY!

- Objective: To demonstrate that air has pressure.
- Materials: An empty duplicating fluid can with screw-on cap, water, electric hot plate and an asbestos pad for safety. (Rinse and clean out can thoroughly before use.)
- Procedure: Pour about an inch of water into the can. Turn the hot plate to the high setting and place the can on it.
Heat it until the steam is coming out of the opening. Wait a few seconds, then TURN OFF THE HEAT. Screw the cap on tightly with a pot-holder.
For safety reasons have all students remain in their seats during this demonstration. For a dramatic effect, set the heated can in a large bowl filled with ice cubes. Wait for the can to cool.
- Observations: When the can was heated, the water turned into steam, driving out most of the air. AS the can cooled, the steam turned back into water, leaving neither air nor steam inside the can, creating a partial vacuum. This caused the can to suddenly collapse.
- Questions:
1. How long did it take for steam to come out of the can? (Usually only a few minutes).
 2. How long did it take for the can to collapse? (Time will vary but about five minutes or so depending on room temperature.)
 3. What caused it to crumble so quickly? (The vacuum inside and the air pressure outside the can.)
 4. Why is this demonstration possibly dangerous? (Heat, steam, and possible danger of the can exploding.)
- Conclusions: As the pressure of the air outside the can became greater than the pressure inside the can, the can just crushed and caved inward.

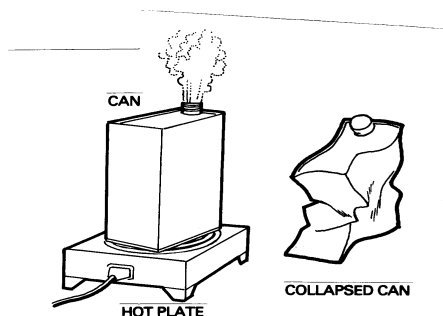

PRESSURE

Objective: To show that air has pressure.

Materials: Water, 2 large flat rubber sink-stoppers for each pair of students. Also 2 new plungers from the hardware store.

Procedure: Wet the entire inside surfaces of the sink-stoppers. Press these two sides together tightly so that no air is between them. With the ring side out, ask your partner to pull on one, while you pull on the other ring. Try to get some short brand-new plungers from the hardware store to use for this experiment. (Compare the efficiency of these vs. the sink-stoppers).

Then, let a little bit of air in between the stoppers.

Observations: When there is no air between the stoppers, it is almost impossible to separate them. After the air is let in between the stoppers, they separate immediately.

- Questions:
1. What happened when you pulled on the wet stoppers? Why? (Nothing happened because the air pressure held them tightly together.)
 2. What happened when a little bit of air came between the stoppers? Why? (The air rushed in and the stoppers came apart.)

Conclusions: Pulling on the stoppers was a tug-of-war since they did not separate. After a little air was let in, the stoppers separated.

This experiment shows that air has pressure. The air pressure separated the stoppers.

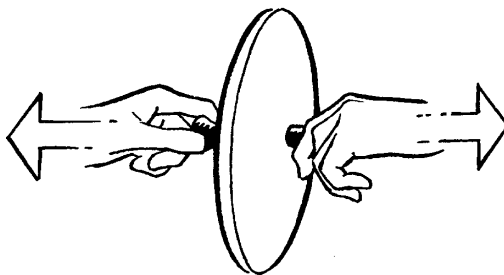

EXPANSION AND CONTRACTION

Objective: To discover that warm air expands and rises.

Materials: Household thermometer.

Procedure: Measure the temperature of the air near the ceiling and then near the floor. Compare the readings.

Observations: The cooler temperature is at the floor level and the warmer temperature near the ceiling.

Questions: Heating ducts are usually located near the floor why? (Because the air near the floor is colder than the air near the ceiling.)

Conclusions: Warm air rises above cooler air.

EXPANSION AND CONTRACTION

Objective: To discover that heat causes air to expand.

Materials: Round balloons, rubber bands, thin string, measuring tape or ruler, refrigerator/ freezing compartment.

Procedure: Blow up a balloon and seal it tightly with a rubber band. Take a piece of string and measure around the balloon. Record the dimensions.
Place the balloon in the freezer compartment for five to ten minutes. Remove, then use the string to measure around the balloon and record these new measurements. (Make sure no air has escaped.) Subtract the two measurements and record this data.

Observations: The warm air from your breath made the balloon big and round.
After the balloon was placed in the freezer it became smaller.

Questions: Did the balloon change in size after it was chilled? Why?
(It shrank in size because the air contracted inside the balloon).

Conclusions: Air has the properties of a gas since it expands when warm, and contracts when cold.

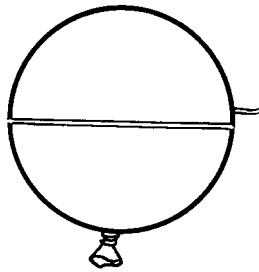

**DIMENSIONS
WHEN WARM**

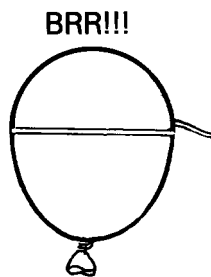

**DIMENSIONS
WHEN COLD**

EXPANSION AND CONTRACTION **(Lesson 1)**

- Objective: To discover that heat causes air to expand.
- Materials: Balloons, water glass, pan of hot water, electric hot plate, scissors.
- Procedure: Heat the pan of water. Cut the neck off a balloon. Place the empty glass into the pan of hot water. Slip the opening of the balloon over the mouth of the glass. Let the glass cool.
- Observations: If one partner holds the glass firmly, it is easier for the other one to slip the balloon over the mouth of the glass. When the glass was cool the balloon is sucked into the glass.
- Questions:
1. What happened to the balloon in the hot water? (It expanded because the heated water warmed the air.)
 2. When the air inside the glass cooled, how did the balloon change? (It contracted and was pulled inside the glass. This showed that heat causes air to expand.)
- Conclusions: When the air inside the glass was heated it expanded. When the air cooled, it contracted and pulled the balloon inside the glass. This showed that heat causes air to expand.

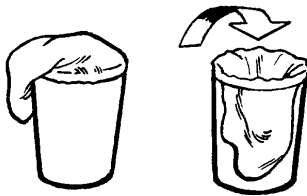

(Lesson 2)

- Objective: To demonstrate that heat causes expansion and contraction.
- Materials: A jar of bubbles or soapy water with liquid detergent in it, bubble pipe, either commercial, or home made.
- Procedure: Blow soap bubbles.
- Observations: The bubbles went up into the air and seemed to float. Then the bubble came down and settled on some objects and burst.
- Questions: What caused the bubbles to float upward and then downward? (Warm breath provided air which rose upwards. When the air in the bubble cooled it sank downward.)
- Conclusions: As the air cooled, it contracted and the bubbles came down and broke.

WATER VAPOR

Objective: To show that air contains moisture.

Materials: Small pan, electric burner, water.

Procedure: Boil a small amount of water in the pan. Observe what happens.

Observations: Discuss what happens when water evaporates. Water also evaporates from rivers, lakes, streams, and ponds.

- Questions:
1. Where was the steam going? (Into the Air.) What is the proper word for this? (Evaporation.)
 2. Ponds, rivers, streams, and lakes also lose water. We know this because the water level recedes, indicating that water also evaporates from these bodies of water.

AIR HOLDS MOISTURE

Objective: To show that warm air holds more moisture than cold air.

Materials: 2 water glasses (aluminum if possible) and a tray of ice cubes.

Procedure: Fill one glass with warm water. Fill another glass with water and ice cubes.

- Questions:
1. What changes did you notice? (The glass with the ice cubes had droplets of water on it.)
 2. Do you know the proper name for the moisture formed on the outside of the glass? (Condensation.)

Conclusions: Water condenses because the cold glass comes in contact with the warm air in the room.

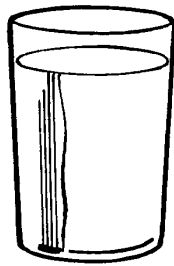

WARM, WATER

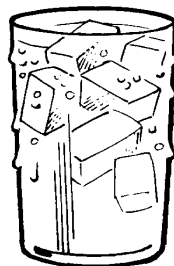

WATER AND ICE CUBES

DENSITY AND TEMPERATURE

Objective: To demonstrate how the density and pressure of a gas varies with temperature.

Materials: Balloons, water, hot plate, large pan or pot, old newspapers.

Procedure: Partially fill the balloon with air and tie it shut. Place it in the boiling water.

Observations:

1. Why was the balloon filled only half full to start with? (To give it room to expand.)
2. The pressure inside the balloon and the density (closeness of the molecules) were changed by what factor? (Rise of temperature of the air inside the balloon.)

Questions: The balloon expanded.

Conclusions: When the balloon was heated, the molecules filled the balloon. When the balloon cooled down, it returned to its original size. This shows that the density and pressure of air varied with temperature.

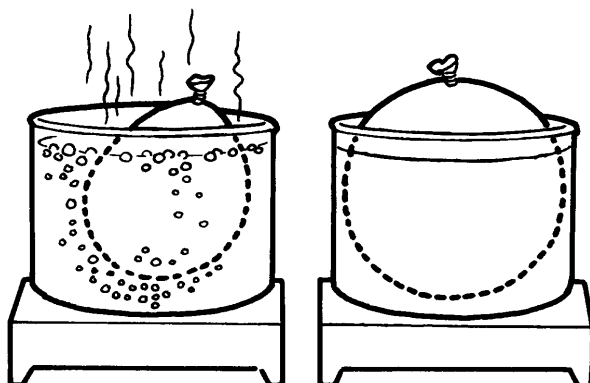

LAYERS OF AIR

Objective: To illustrate that air separates into layers the same as oil and water.

Materials: Jar and lid, cooking oil, water, food coloring, old newspapers, soap and water to wash hands.

Procedure: Fill the jar half-way with cooking oil. Add colored water and fill the jar to the top. Put the lid on the jar and shake it for 10 seconds. Let it stand and look at it again in 30 minutes.

Observations: The oil separated and went to the top layer of the jar.

- Questions:
1. Why was the water colored before using it? (To make it more visible.)
 2. What happened when the colored water was added to the oil? (The oil and water separated, the oil came to the top.)
 3. What happened after the jar was shaken and let stand for 30 minutes? (The oil and water separated, the oil came to the top.)
 4. In the atmosphere when cold (heavy) air is mixed with hot (light) air, it will act like the oil and water. (Describe what occurs. (Hot air always goes to the top and cold air goes underneath, to the bottom layer.)

Conclusions: Hot air is lighter than cold air, therefore it pushes upward to the top in a similar manner as the layers of oil and water.

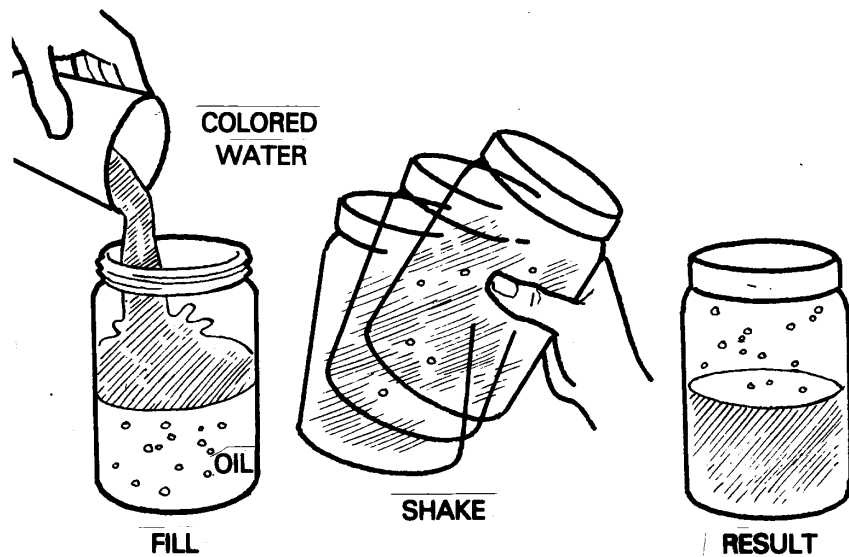

MEASUREMENT OF AIR

Objective: To demonstrate that air moves.

Materials: Paper cut into a 6 inch square, straight pins, pencils with erasers or thin dowel rods.

Procedure: Draw diagonal lines across the 6 inch square of paper. Cut along the lines to a point about one-half inch from the center of the square. Bring alternate points together so that they overlap in the center. Push the pin through the points of the paper and the center of the square, then into the eraser on the end of the pencil. Blow on the pinwheel. Run with it, holding it at different angles as you run. Hold it near an electric fan.

Observations: The pinwheel moves when you blow on it, also when you run with it, and it moves very fast when it is in the path of an electric fan.

Questions: Which direction does the pinwheel turn? How can you make it go faster? Slower? (The pinwheel will turn opposite the wind direction. It goes faster when you run and very fast near the fan, blowing gently makes it go slower.)

Conclusions: The pressure of air can cause other objects to move.

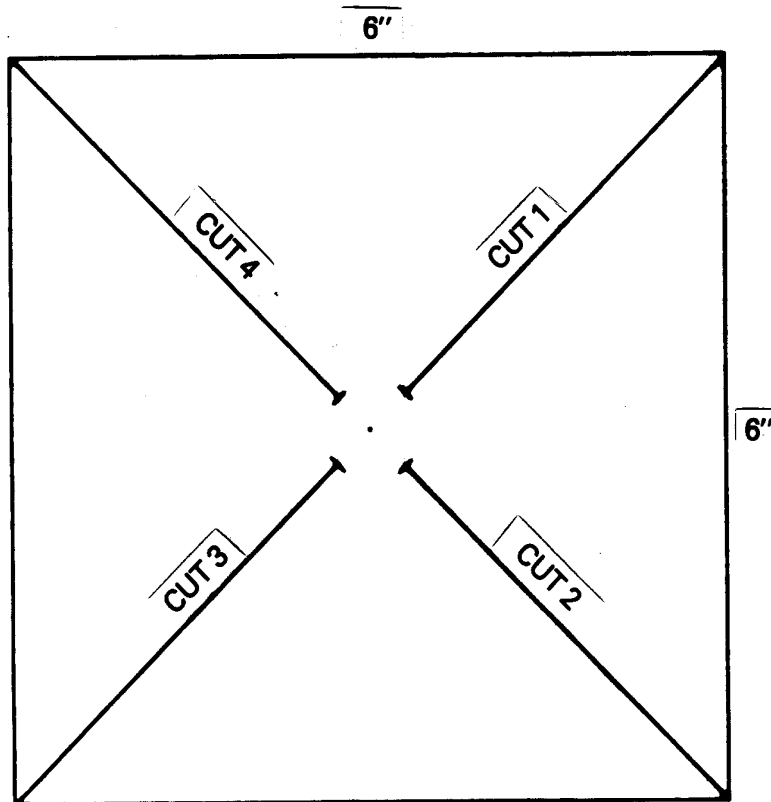

PIN TO CENTER CORNERS

MOVEMENT OF AIR

Objective: To demonstrate that air moves.

Materials: Perfume, matches and punk, piece of string, dish, a paper fan.

Procedure: Put some rather strong perfume on a piece of cotton. Let this sit on the teacher's desk. Students will raise their hands as soon as they smell the odor.

DEMONSTRATION ONLY: Burn the punk or string in a dish. Watch the movement of the smoke when the door is opened/closed.

Use a folded paper fan to fan yourself. Move your arms rapidly while rotating around the room. Feel the air. During a storm look out of the windows. Note how the wind affects the trees, leaves, and other objects.

Observations: The perfume gradually reached the back of the room and students were able to smell it in a short period of time. When the air in the room was calm, the smoke went straight up. When the door was opened, the breeze caused the smoke to go in different directions. The paper fan and use of the arms caused the air to move around the body. The wind moved the leaves, trees, and other objects outside.

- Questions:
1. How long did it take for you to smell the perfume? (Varies, from one minute to long enough for smell to reach back of room.)
 2. Why didn't everyone smell it at the same time? (It took time for air molecules to circulate in the room.)
 3. Why did the smoke move when the door was opened? (The air outside the door moved in and caused the smoke to move.)
 4. Did your fan cool you off? Did you feel the air on your arms as you moved them? (Yes.)
 5. Where do the leaves go when the wind blows? What makes them flutter down? (First they fly up into the air, then gravity pulls them down.)

Conclusions: Wind is moving air all around us. It affected all the materials described in this experiment.

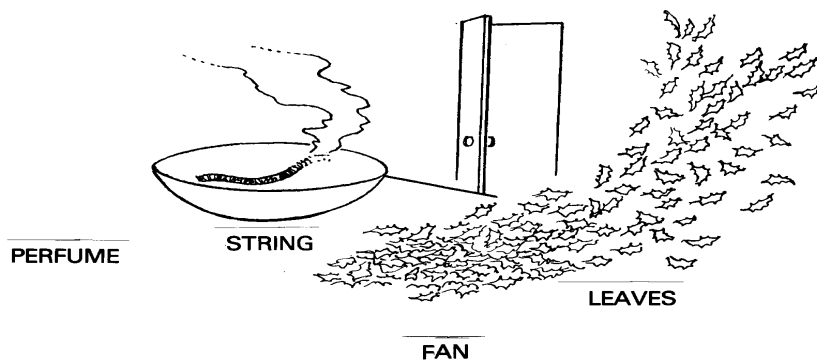

LIFT/RESISTANCE

- Objective: To demonstrate that air will support some things such as a parachute aloft.
- Materials: Circles 12" or above, of lightweight nylon, pliable plastic or other materials, cardboard cutout of a pilot, a medium size bolt or other small lightweight objects, pipe cleaners, needles and heavy duty thread.
- Procedure: Cut 6 pieces of thread the size of the diameter of the circle. Using the needle, attach them at equal intervals around the circumference of the circle. Knot the six lines. Be sure they are the same length. Attach the cardboard pilot to the lines with the pipe cleaner. Toss into air and let the parachute descend. Make a small hole in center of the chute. Experiment with different size chutes. Tie one of the lines shorter than the rest and experiment.
- Observations: The resistance of the air limits terminal velocity. The hole in the center of the chute provides an air vent which helps stabilize the parachutes descent.
- Questions: How does the surface area of the parachute help in its descent? (It acts as an air brake which slows it down.)
- Conclusions: The large surface of a parachute acts as an air brake, checking the velocity of the person or object attached and making possible a safe landing.

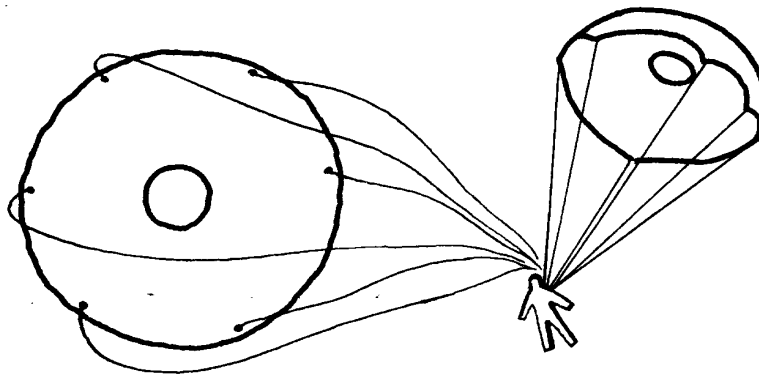

LIFT/RESISTANCE

Objective: To demonstrate that air will support some things (such as a kite) aloft.

Materials: 2 sticks, $1/4" \times 3/8" \times 24"$; paper, strong, $16" \times 24"$; glue; long, narrow strip of cloth; string.

Procedure: Assemble the kite (see diagram) and let the glued parts dry thoroughly. Wait for a windy day and fly it.

Observations: The kite flies when held at an angle to the wind. This allows the air to strike against the undersurface of the kite. This will direct the kite upward as the air striking the kite is deflected downward.

When the kite string is released, the kite falls to the earth. This is because the angle at which the surface of the kite has been held toward the wind has been changed.

The string keeps the kite headed into the wind. The tail keeps the kite upright. Gravity tends to pull the kite down.

- Questions:
1. What is the use of the kite string? (Answers will vary but the string keeps the kite headed into the wind.)
 2. Should the tail be long or short? Why do you need the tail? (Long ones work best. The tail keeps the kite upright.)
 3. What brings the kite down? (Gravity)
 4. Is wind pressure important to this experiment? Explain. (This is the force that holds up the kites.)

Conclusions: Wind helps a kite fly, unless the kite is being pulled through the air. The lift upward caused by the angle at which the kite attached the air is greater than the pull of gravity downward.

Wind pressure (air) beneath the kite tends to hold it up in the sky.

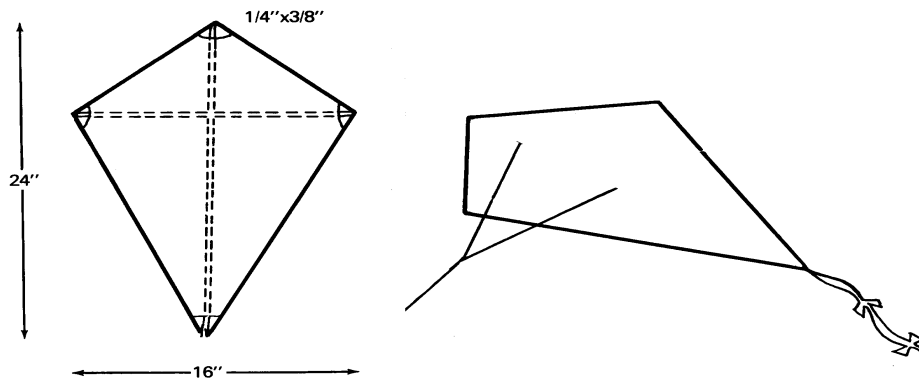

II. LIGHTER-THAN-AIR FLIGHT

Balloons and blimps float in the air. "Around the World in 80 Days" was a movie showing how, with skillful maneuvering and planning, a journey was made around the world by many modes of transportation including the hot air balloon. The hot air balloon was very popular as recently as the late 1800's.

Lighter-than-air flight has been a dream of mankind from time immemorial. Leonardo da Vinci made detailed drawings of flying machines and countless unfortunate people tried to imitate the birds.

Temperature of the air and awareness that hot air is lighter than cool air are prime factors in lighter-than-air flight. The hot air created inside the balloon causes it to rise. When heat is shut off--the balloon will descend. Launching a hot-air balloon is a classic project for a class of future aviators. They will long remember the preparation and "take-off" of their lighter-than-air flight.

FLOATING IN AIR

Objective: To demonstrate why balloons float in the air.

Materials: Balance, cooking oil, water, 2 beakers or containers of equal weight.

Procedure: Balance the two containers on the scale. Add equal amounts of water and cooking oil to each container. Mix some water and oil in a bucket and shake it. Put a hollow rubber ball in a bucket of water. Push the ball to the bottom and let go. Let stand.

Observations: The beaker containing water is heavier than the one containing the cooking oil. It goes down to the table top. The oil floats to the top when mixed with water. The rubber ball floats to the top of the water.

Conclusions: Water is heavier than oil, therefore the oil will float to the top of the beaker if mixed. The hollow rubber ball is lighter than the water, therefore it will float to the top of the water.

Make the analogy that blimps, balloons, and other lighter-than-air craft fly because they are lighter than the air surrounding them. They float upward like a hollow ball floats to the top of water.

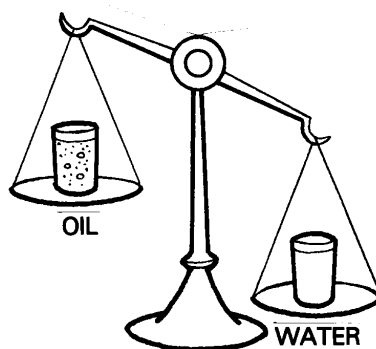
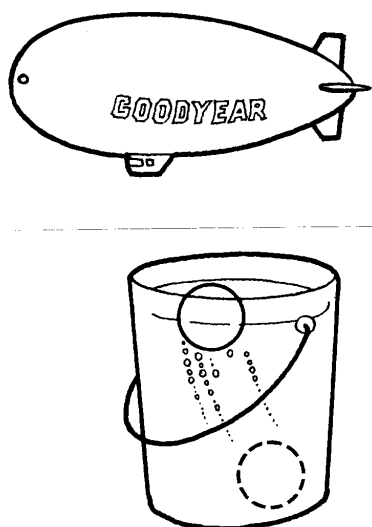

RISING HOT AIR

THIS EXPERIMENT IS FOR DEMONSTRATION ONLY

Objective: To demonstrate that hot air rises.

Materials: A balance, candle, aluminum foil, washer (or other light weight).

Procedure: Make a large hollow ball out of aluminum foil. Attach it to one arm of the scale. Attach enough weight to the other arm to balance the scale. Hold a lit candle under the foil.

Observations: As the flame heats the air, it becomes lighter and the surrounding air will push the hot air and foil upward.

- Questions:
1. Did you see that the hollow foil ball and the weight really balanced? (Yes.)
 2. What changes occurred after the ball was heated? (The balance showed the ball went up and the weight down.)
 3. What caused this change? (The hot air inside became lighter and rose.)

Conclusions: Because hot air is lighter, it is pushed upward by cooler, heavier air. (Other gases that are lighter than air are hydrogen and helium, both of which have been used in dirigibles.)

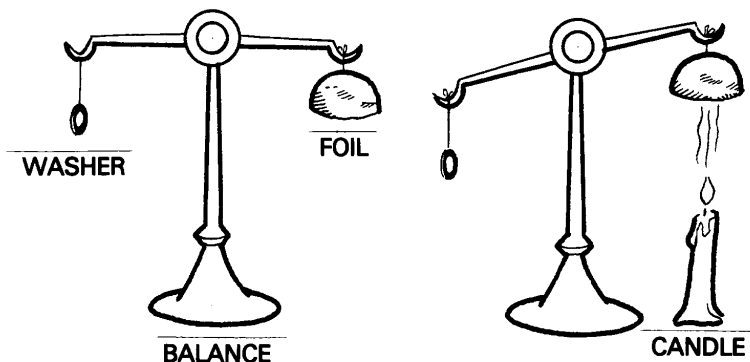

HOT AIR MOLECULES

THIS EXPERIMENT IS FOR DEMONSTRATION ONLY

Hot air is light because the molecules of air move faster when heated. Water molecules also move faster when heated. You can see the results of heated water as you watch it boil. As air molecules "boil" or move rapidly, they spread out and there are fewer in a given area.

Objective: To show what happens to air molecules when they are heated.

Materials: Electric hot plate, balloons, empty soda bottles, water, deep sauce pan, pot holders, scale.

Procedure: Weigh the soda bottle.
Put some water in a sauce pan and place it on the hot plate. Place the balloon over the top of the soda bottle and put the bottle in the water. Heat the water. Weigh the soda bottle again.

Observations: As the air molecules in the bottle warm up, they begin to spread out and fill the balloon.

- Questions:
1. What took place when the water was heated? (The limp balloon filled with air and expanded.)
 2. Why did this happen? (As the air molecules in the bottle warm, they begin to spread out and fill the balloon.)
 3. What will happen when the water cools? (Balloon will shrink.)

Conclusions: There are fewer air molecules left in the bottle so air in the bottle weighs less than it did before it was heated.

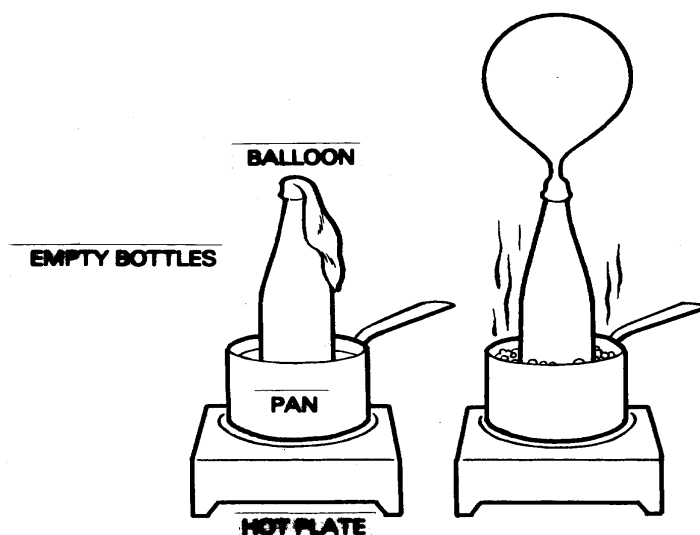

SOAP BUBBLE BALLOON

- Objective:** To demonstrate that hot air rises and can be used to make things fly.
- Materials:** Box of ivory soap flakes, bottle of glycerine, small thin paper disks, water, thread, scissors, tissue paper and small pattern, straight straws, mixing bowl, spoon.
- Procedure:** Use about a cup of soap flakes and add enough water to make a stiff lather. Add a little glycerin for elasticity. Mix. Cut out a tissue paper figure about 1" high and glue it to a 1/2" thread attached to paper disc.
Go outside when it is chilly or find a cold room to do this experiment. Dip the straw into the soap solution. Blow carefully until you get a perfect bubble.
Have a partner carefully place the dry paper disc onto the bubble. As soon as the disc sticks firmly, turn the straw upward to set the balloon free.
- Observations:** The bubble may break several times before a disk will stick firmly.
The balloon (bubble) did rise up into the air.
- Questions:**
1. Why does this experiment only work when it is in a cold place? (Hot air always rises. Your breath has hot air so if the room is cold, it will quickly rise.)
 2. How would the bubbles act in a heated classroom? (In hot weather they would not rise high; at room temperature they would rise slowly but not too high.)
- Conclusions:** A soap bubble balloon will fly up rapidly in a cold place due to the warm air inside of it.

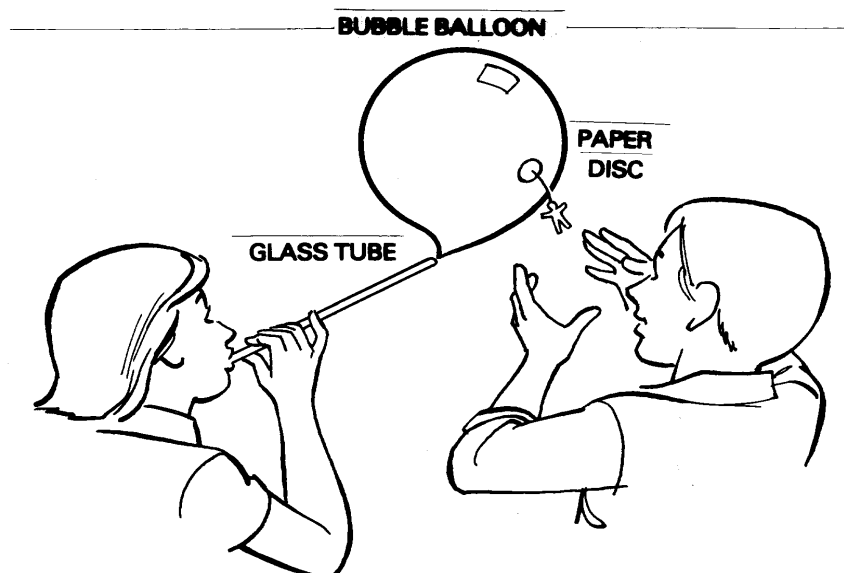

BALLOON FLIGHT

Objective: To demonstrate how a balloon can zoom through the air.

Materials: Round balloons.

Procedure: Blow up a balloon and hold it tightly around the neck. Release the balloon.

Observations: As long as the neck is kept closed, the air inside the balloon presses equally on the entire inside surface of the balloon. By poking gently at the balloon, you feel that the tension on the entire surface is even. When the balloon is released, it moves through the air until air is exhausted from inside the balloon.

Questions: What could be done to make the balloon fly straight? (Answers will vary, but squeezing the neck and releasing it at an angle may help.)

Conclusions: The balloon generally travels opposite the opening. As air escapes, it is an action which, according to Newton's third law of motion, produces an equal and opposite reaction.

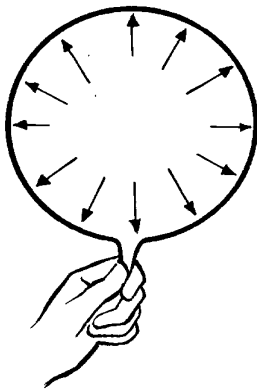

PRESSURE EVEN ALL AROUND

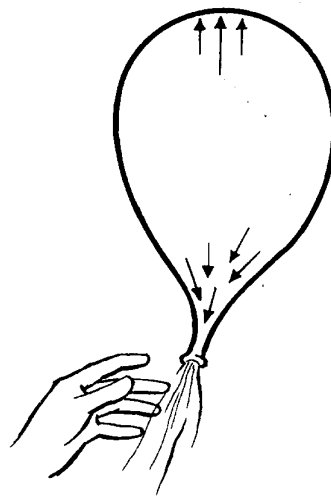

BALLOON CHANGES SHAPE AND STARTS TO MOVE FORWARD AS PRESSURE IN BACK EXCEEDS PRESSURE IN THE FRONT

HOT-AIR BALLOON

ADULT SUPERVISION ESSENTIAL! DO THIS OUT DOORS ONLY!

Objective: To make a hot-air balloon with a controlled heat source.

Materials: A light-weight paper bag, cotton balls, work gloves, heavy scissors, rubbing alcohol, thin wire mesh (screening will work), thin wire, wire cutters, cigarette lighter, an open box of baking soda to put out fire if necessary -- safety precautions.

Procedure: Form a basket from screening and wire to fit securely under the opening of the paper bag. (See picture.)
Dampen cotton balls with the alcohol (DO NOT SATURATE, and place in the basket.
Use the lighter to ignite the cotton and step back out of the way!

Observations: The hot air produced on the burning cotton caused the bag to rise.

Questions:

1. Why did the balloon rise? (The fire made hot air inside the bag causing the bag to rise above the cooler air level near the ground.)
2. Name the controlled heat source. (The amount of cotton and the amount of fuel (alcohol) used. This can be measured, therefore, it can be controlled.)

Conclusions: The paper bag hot-air balloon rose up in the air until the controlled heat source was used up.

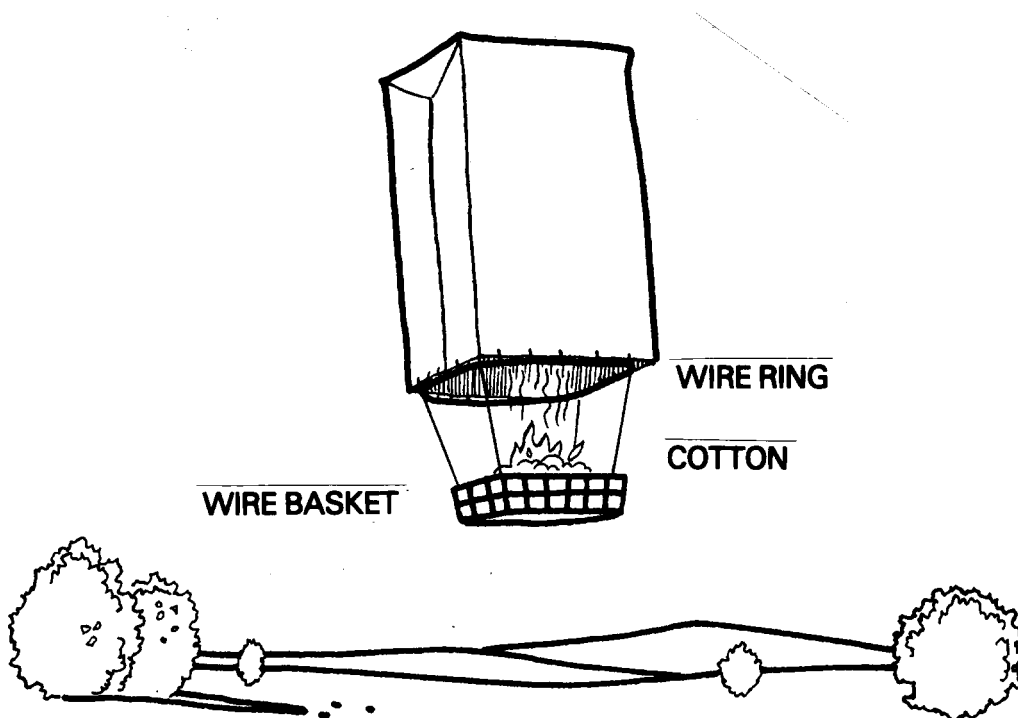

HOT-AIR BALLOON

Objective: To make and launch a hot air balloon - out of doors.

Materials: Round, large size balloons, tissue paper, liquid starch, string, thin cardboard, small candle, lighter.

Procedure: Inflate the balloon and tie. Cut small squares, about 4" x 4" from the tissue paper and dip them in the starch. Cover the entire balloon with several layers of paper overlapping the previous one. Allow to dry at least a day. Puncture the balloon and remove it from the model by making an opening in the bottom. Make a small basket from the cardboard. Line it with a small piece of foil. Attach the basket to the balloon with four pieces of string. Attach several pieces of string to the gondola that will hang down as ground lines. Secure the candle to the gondola, light it and be ready for lift-off.

Observations: The balloon started to rise very quickly after the candle was lit.

- Questions:
1. What gas was used in early days to fill passenger balloons? Why? (Hydrogen was used because it is a gas lighter than air and could lift balloons easily.) Why isn't it used anymore? (Hydrogen is highly flammable and therefore dangerous.) (Helium is often used now because it is not flammable.) It is used in large blimps and air ships that remain inflated for some extended period of time.
 2. Most large balloons in use today use hot air. Why is this a better choice? (Air is safe to use, there is plenty available and it is free.)
 3. What is done to make the balloon rise? (The air inside the balloon is heated to at least 100°F(38°C). Since warm air always rises above cool air, the balloon begins to float on the cool air and rises.)
 4. Can you name some of the parts of a hot air balloon? (The envelope of nylon is the balloon part. The gondola, or basket is attached to the envelope by ropes. This is where the passengers ride and it also holds the materials that make the heat. Ground lines are the ropes which hang down and keep the balloon tied tightly until it is ready to be launched.)
 5. What are the duties of the pilot and crew? (The pilot must check wind speed and direction. The readings must be less than 8 miles per hour (13 kilometers per hour) for a safe take-off. The crew will open the envelope and attach the gondola. The ground lines are tied tightly. A fan is then turned on to blow the air into the balloon. Then a blowtorch is turned on to warm up the air. The balloon is ready to fly when it is full of hot air and standing upright.)
 6. After the pilot gives the signal to launch, what does s/he do? (S/He must constantly check the temperature with a special thermometer called a pyrometer, to make sure the temperature is kept just right. S/He makes the balloon go either up or down by regulating the heat. But s/he cannot control the wind, so sometimes the balloon goes either too fast or too far away from his original route.)
 7. When the pilot decides it is time to land, what does s/he do? (S/He slowly opens a vent in the top of the balloon to let some air out. S/He does this carefully so the trip down is as smooth as possible. Then a waiting truck picks everyone up and takes them back to the launch site.)

Conclusions: A pilot and crew control the launching and landing of a balloon by regulating the amount of hot air needed to make it rise and fall.

HOT AIR BALLOON

THIS EXPERIMENT IS FOR DEMONSTRATION ONLY!

Objective: To show how air can have lifting properties.

Materials: Plastic clothes bag, aluminum foil to make a small chimney, scotch tape, can of Sterno, lighter.

Procedure: Make a small vertical chimney large enough to fit over the canned heat. Open the bottom of the bag. Fold over the top of the bag and tape it tightly shut. Fill the bag with air by moving it with your arms. Slide the air filled bag over the hot chimney. Hold the bottom edge of the bag gently with your hand on the table top.

Observations: Hot air from the chimney began filling the bag. As the bag filled with hot air it pulled away from the table top and rose to the ceiling.

- Questions:
1. Was the air in the bag at room temperature at the beginning of this experiment? (Yes -- relatively cool.)
 2. How did the temperature inside the bag change? (The heat from the can rose up the chimney causing the air in the bag to heat up.)
 3. How did the bag float up the ceiling? (Hot air rises over cool air. When there was plenty of hot air in the bag, the bag seemed to lift itself off the table.)
 4. What was keeping the bag from lifting off too soon? (The force of your hand holding the bag down.)
 5. How did you know when to release your hand? (When you felt a slight pulling on the edge of the bag.)
 6. If the bag stops suddenly before touching the ceiling, what might cause this problem? (The bag may have hit a pocket of hot air whose density is the same as the air inside the bag. If this should happen, have someone stand on a chair and hold up a hand to feel the hot air.)

Conclusions: Air when warmed rises and has lifting properties. The air inside the bag was hot enough to move it from the cool air on the table up to near the ceiling of the room.

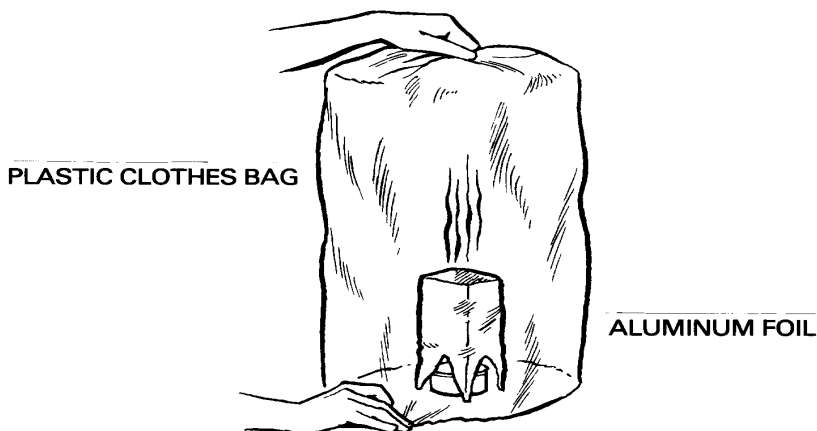

ARCHIMEDES PRINCIPLE

Objective: To verify Archimedes' Principle

Materials: Spring balance suspended on a rod on a ring stand, small brick, large size glass container, water, ruler.

Procedure: Archimedes' Principle: Any object immersed in a liquid is buoyed up by a force equal to the weight of the liquid displaced. (About 200 B.C.)

Carefully measure the length, width, and height of the brick. Record results. Calculate the volume: length x width x height = ___ cu. in. Suspend the brick from a string on the spring balance. Read its weight and record (ounces). (If using metric measurements, the weight will be in grams, and the volume will be in cubic centimeters.)

Observations: The brick "lost weight" when it was put into the container of water.

- Questions:
1. Why did the brick "lose weight" when it was submerged in the water? (The water exerted a buoyant force (power of supporting a floating body) upon the brick.)
 2. Did the level of the water in the container change? Why? (Yes, the level went up as the brick was added -- in other words, the water was displaced as the brick went into the water.)
 3. How does Archimedes' Principle apply to lighter-than-air craft? (A blimp moves through the air easily because air has fluid properties just as liquid does. The air actually supports the blimp as a floating body because it flows all around it by a force equal to the displaced air.)

Conclusions: The difference in weight between the brick in air and in the water is equal to the weight of the displaced water. Archimedes' Principle concerns fluids in motion, so that it applies equally well to a flow of water or air.

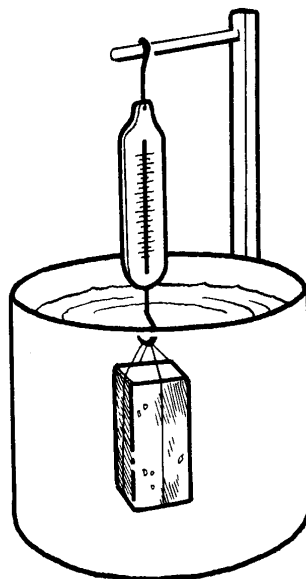

III. WHAT MAKES AN AIRPLANE FLY?

The force that lifts an airplane and holds it up comes in part from the force of the air that flows over and under its wings.

The force was identified and is called Bernoulli's principle. Bernoulli is a family name. There were eight male members of this family who were all scientists working together. They modified and refined their observations and conclusions. Thus, Bernoulli's principle, in its present form is applicable to many scientific situations.

This principle states that an increase in the velocity of any fluid is always accompanied by a decrease in pressure. Air is a fluid. If the air can be made to move more rapidly on one side of the surface, the pressure is less on that side. The pressure is greater on the opposite side.

Bernoulli's principle works with an airplane wing. In motion, air hits the leading edge (front edge) of the wing. Some of the air moves under the wing, and some of it goes over the top. The air moving over the top of the curved wing must travel farther to reach the back of the wing; consequently it must travel faster than the air moving under the wing, to reach the trailing edge (back edge) at the same time. Therefore, the air pressure on top of the wing is less than that on the bottom of the wing.

Wings give an airplane lift, but they do not drive it forward. In some airplanes, the propeller (turned by an engine) drives the plane forward by pushing the air backward. The air reacting to the action of the propeller, pushes it forward (Newton's Third Law of Motion states: For every action, there is an equal and opposite reaction). So, because the propeller is attached to the plane, it pulls the plane through the air.

What makes a jet aircraft fly? It has no propeller--instead it has a reaction engine in which fuel is burned to expand the air and build up great pressures. It also has a tailpipe through which the expanded air and other gases can escape. The plane moves forward because of the pressure of the gases inside its engine.

How is an airplane controlled in flight? It must be steered to go right and left as well as up and down. The parts on the wings and tail that control these movements are called control surfaces. Folded paper gliders and balsa gliders may be used to show that control surfaces can be maneuvered successfully.

NEWTON'S THIRD LAW

Objective: To demonstrate Newton's Third Law of Motion.

Materials: A collision ball apparatus. This can be obtained from a science museum store or a science supply house.

Procedure: Raise one ball and let it fall. Raise two balls and let them fall.

Observations: When one ball was let fall, one ball on the opposite end, moved up. When two balls were let fall, two balls on the opposite end, moved up.

- Questions:
1. Why did the balls on the opposite end fly up? (Newton's Law says: to every action there is an equal and opposite reaction. Note: In reaction, two different bodies are always involved. So, if one ball is lifted up, an equal force of one ball will fly up on the other end, etc.)
 2. Give another example of action and reaction. (The reaction of the air against the wings of a bird enables it to fly. This applies for airplane flight also.)

Conclusions: Newton's Third Law showed that for every action there is an equal and opposite reaction -- the force of one raised ball, hitting the center balls, transmitted this equal force to the end ball and caused it to fly up.

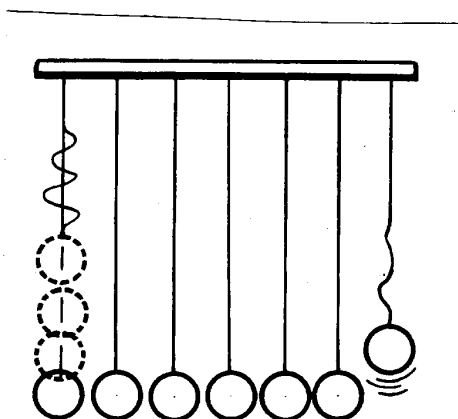

NEWTON'S THIRD LAW

Objective: To test Newton's Third Law of Motion.

Materials: Tin can, string, nail or awl, sink or large dish pan, pitcher of water.

Procedure: Punch a hole in the side of the can near the bottom. Suspend the can from a string and hold it over the sink. Pour water into the can.

Observations: The water rushes out of the hole at the bottom of the can.

- Questions:
1. What makes the can move when water comes out of the hole? (Newton's Law states: to every action there is an equal and opposite reaction. When the water comes out of the hole, which is the action, the can moves away from the hole, which is the reaction.)
 2. How does this experiment apply to an airplane's motion? (The air reacts against the propellers of an airplane as they drive the plane forward, and the reaction against the plane has two elements, one of which lifts the plane. The other element, gravity, pulls it down.)

Conclusions: Newton's Third Law of Motion works -- the can did move in the direction opposite the water stream.

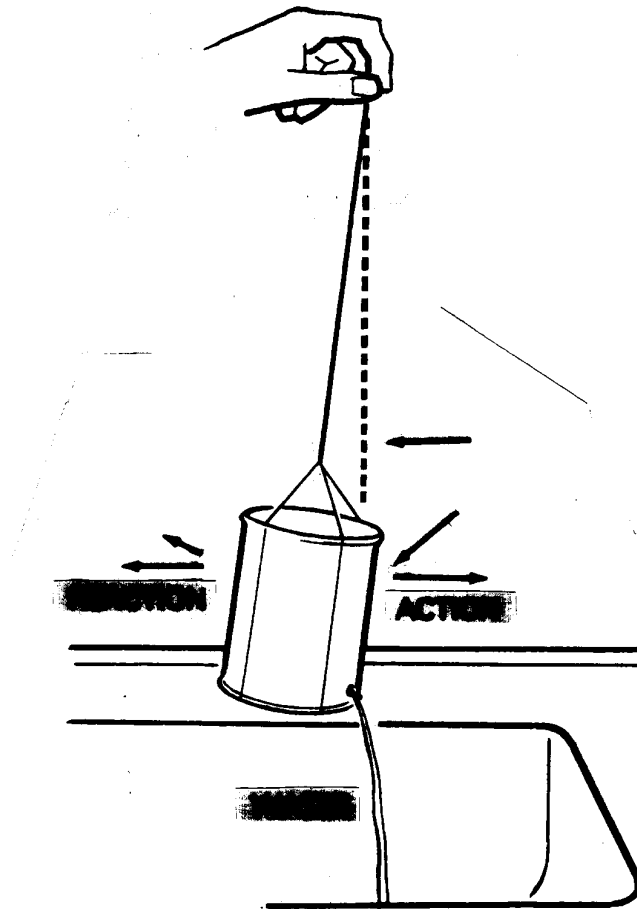

AIR FLOW

- Objective: To show how air flow over and under wings influence flight -Bernoulli's Principle
- Materials: 2 sheets of notebook paper.
- Procedure: Hold two sheets of notebook paper about four inches apart. Blow between them.
- Observations: Instead of flying apart the sheets come together.
- Questions:
1. What did you expect to happen? (Probably separate.)
 2. How would moving air affect the wings of an airplane? (The faster moving air on the top has less pressure and the slower moving air underneath has more pressure.)
 3. Can you say, and also spell the man's name, "Bernoulli"? (Bernewly -- B E R N O U L L I.)
- Conclusions: The air moving rapidly between the two pieces of paper has less pressure than the air pressing on the outer sides of the paper.
- NOTES: Bernoulli's Principle states that an increase in the velocity of any fluid is always accompanied by a decrease in pressure. Air is a fluid. If you can cause the air to move rapidly on one side of a surface, the pressure on that side of the surface is less than that on its other side.
- Bernoulli's Principle works with an airplane wing. In motion, air hits the leading edge (front edge) of the wing. Some of the air moves under the wing, and some of it goes over the top. The air moving over the top of the curved wing must travel farther to reach the back of the wing; consequently, it must travel faster than the air moving under the wing to reach the trailing edge (back edge) at the same time. Therefore, the air pressure on top of the wing is less than that on the bottom of the wing and the difference in pressure results in lift.

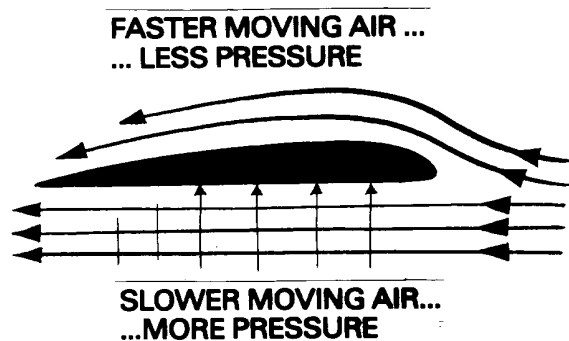
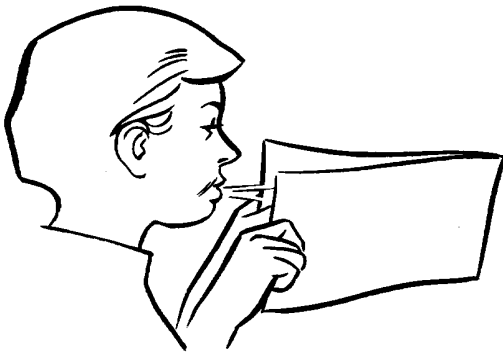

AIR FLOW

Objective: To discover that air flow can keep objects suspended in the air.

Materials: Ping pong balls, tank-type vacuum cleaner, or blow dryer; (try using beach balls, balloons, etc. in place of the ping pong balls).

Procedure: Connect the hose to the blower rather than to the suction end of the vacuum cleaner. Turn the switch on. Hold the hose vertically so the stream of air goes straight up. Release the ping-pong ball into the stream of air about a foot from the nozzle. Slowly tip the nose so that the air shoots at an angle.

Observations: The ball will stay suspended in the airstream. The force of gravity upon the ball tends to make it drop out of the airstream. However, the fast moving airstream lessens the air pressure on the portion of the ball remaining in the airstream.

- Questions:
1. What happened to the ball when it was held too close to the nozzle? (Drops to the floor.)
 2. What happened to the ball when it was held too far away from the nozzle? (Drops to floor.)
 3. What happened to the ball when it was held about a foot from the nozzle? (Hopefully it will stay suspended in the stream of air.)
 4. Why doesn't gravity pull this ball down? (The stream of air exerts more force on the ball than gravity does, so it remains suspended in the stream of air.)
 5. Try a tennis ball or rubber ball. Does the air in the nozzle suspend these balls too? Tell what happened. (The balls probably will be too large or too heavy and will fall down.)

Conclusions: When the force of gravity is overcome, the result is that the ball remains suspended.

Note: This activity can be done also by having students blow through a flexible straw.

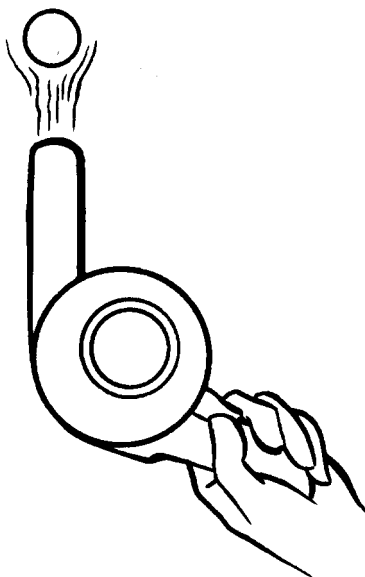

DRYER

GLIDERS

Objective: To observe that changing movable parts of a glider will change the flight pattern.

Materials: Outline of glider, light cardboard, paper clips, tracing paper, scissors.

Procedure: If using balsa wood, etc., this will take several class periods. Some construction could be assigned for homework.

Use tracing paper to copy the glider pattern. Trace the diagram on the folded piece of cardboard, placing the long straight line on the folded edge. Cut along the traced line. Bend the wings and tail as indicated. Using drawing B, outline the ailerons, rudders and elevators. Cut along the solid lines and score the dotted lines. The finished glider should look like the picture at the bottom of the page.

Observations: Write down what you observe from questions 1-6.

Questions: How does the glider change when:

1. Bend both rudders right.
2. Bend both rudders left.
3. Bend both elevators up.
4. Bend both elevators down.
5. Bend the right aileron up and the left one down.
6. Bend the right aileron down and the left one up.

Conclusions: This model glider seems to correspond to a small plane in flight. The adjustment of the control surfaces causes the glider to fly different ways.

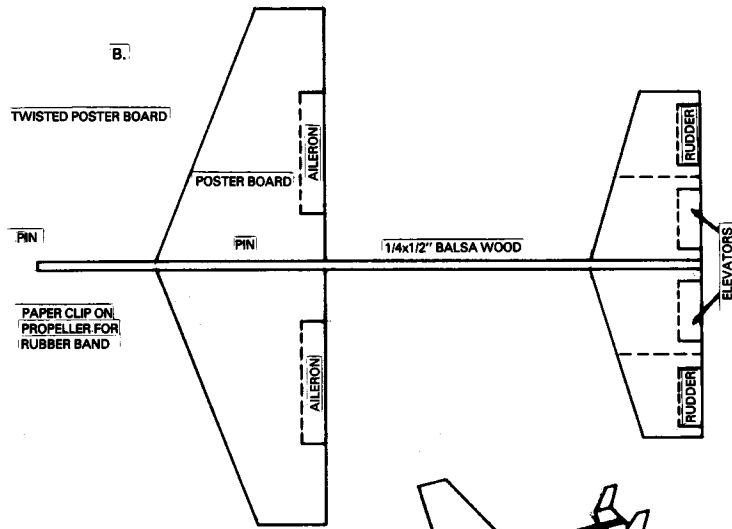
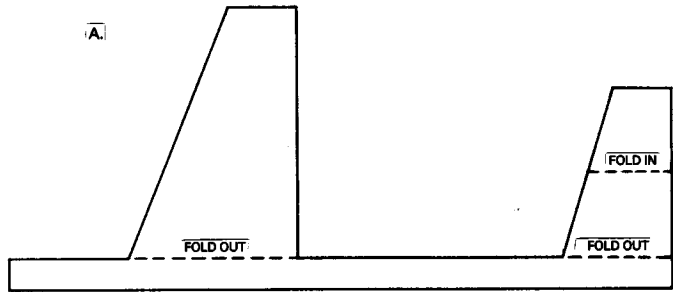

NOTE: ENLARGE XEROX COPY FOR PATTERN OUTLINE

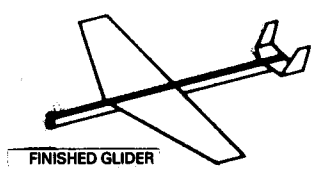

FINISHED GLIDER

PARACHUTES

- Objective: To make and compare the effects of different parachutes on the speed of falling objects.
- Materials: Cloth or handkerchiefs of different sizes, string, small objects which can be tied to the string, such as, tiny toys, erasers.
- Procedure: Tie string to four corners of a square of cloth and then attach the other ends to a small toy or other object. Drop two similar objects from the same height, one with a parachute, the other without a parachute.
- Try different shapes of parachutes, multiple parachutes or parachutes of different materials.
- Observations: The parachutes float down to the ground. Similar objects without parachutes fall rapidly to the ground.
- Questions:
1. What happened when you tried two different size parachutes with the same weights? (The larger size parachute took longer to come down.)
 2. What part does a parachute play in the safety of a person jumping from a plane or in the recovery of a space capsule? (The person will float down to the ground -- without a chute there is danger of the person being killed. The space capsule will also come down for a softer landing on the water saving the lives of the astronauts inside and the capsule's valuable instruments.)
- Conclusions: Larger parachutes and multiple parachutes come down slower than smaller sized parachutes.

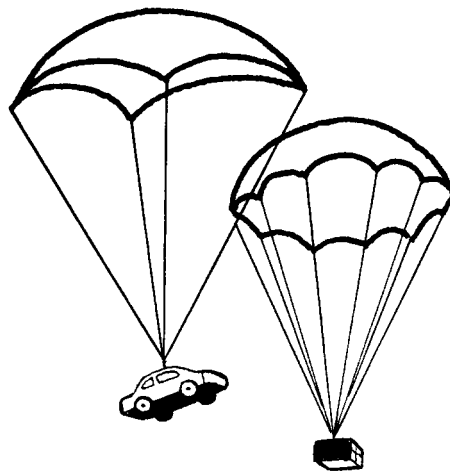

PARACHUTES

Objective: To design and make a parachute which will protect a raw egg from breaking on impact.

Materials: Eggs, string, cloth, plastic and "you name it."

Procedure: Design and make a regular small parachute. Demonstrate your model. Design a second parachute for the specific purpose of protecting a raw egg from breaking after a drop from the height of a two-story window. When parachute is completed, demonstrate its usefulness.

Observations: It took a long time and several tries to make a soft landing for the egg.

- Questions:
1. What were some of the problems you had? (Breaking, tangling lines, etc.)
 2. Which materials proved the most successful? (Answers will vary.)
 3. How many times did your try before the egg landed safely? (Answers will vary.)
 4. Did the color of the material make any difference (No.)
 5. What advice would you give to others doing this project? (Accept all advice given.)

Conclusions: It is possible to design a parachute that will protect an egg from breaking.

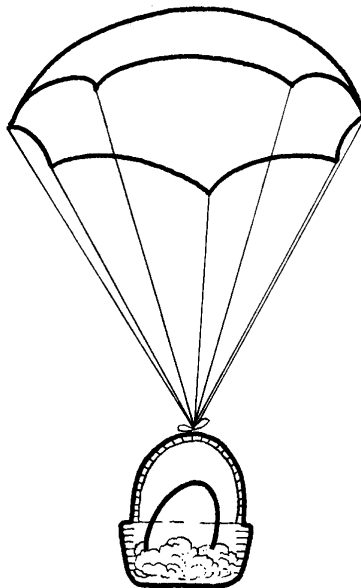

GRAVITY

- Objective: To discover whether a heavy or light object reaches the ground first.
- Materials: Chair or sturdy table, two objects such as one heavy stone, one light object such as a ping-pong ball, watch with a second hand.
- Procedure: Stand on the table and drop the two objects at the same time. Repeat several times and try to time them.
- Observations: Both objects hit the floor at the same time.
- Questions:
1. Were you surprised at the results? Why? (Yes, possibly reasoning that the heavy object would fall faster.)
 2. Why doesn't a feather fall as fast as a stone? (The shape of the feather offers a larger surface to the air and is slowed down by the air's resistance, so it floats down.)
 3. Why does a parachute slow down a person's descent? (The chute is slowed down because it is so large and catches a lot of air in it, it drifts down, instead of just falling.)
- Conclusions: The weight of an object does not affect its speed as it falls, if the friction of the air is not considered. (This is in accordance with Newton's second law of motion).
- Note: The force of gravity is greater on the body which has the greater mass but the body of greater mass requires a greater force to accelerate it. Thus, both bodies fall at the same rate and reach the ground at the same time. To demonstrate the effect of the friction of air on falling bodies, try this experiment in a vacuum condition.

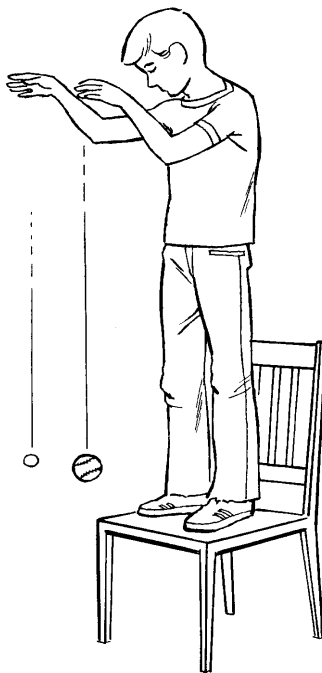

THRUST

Objective: To demonstrate how a propeller pulls an airplane through the air.

Materials: Small wagon or roller skates, small electric fan with long extension cord.

Procedure: Put a propeller on anything that can move with wheels--a wagon or a roller skate. Use a small electric fan with a very long extension cord for a propeller. Set it firmly on the roller skate or wagon. Turn on the fan.

Observations: The fan drives the wagon or skate backwards.

Questions:

1. Why did we use a small wagon for this experiment? (The large and heavier ones would not move.)
2. What happened when the fan was turned on? (Hopefully, the fan will move the wagon backwards.)
3. Did you get different results with the skates. What happened this time? (The skates moved backwards too.)
4. What might happen if you used a more powerful fan? (Maybe the object would move faster, or. . . .)
5. Why do you think the propeller blades on an airplane are designed in such a special way? (So it will pull the propeller and plane through the air.)

Conclusions: The propeller makes the roller skate go backwards because the blades are set to throw the air in front of the fan.

NOTES: Wings give an airplane lift, but they do not drive it forward. In some airplanes the propeller (turned by an engine) drives the plane forward by pushing the air backward. The air, reacting to the action of the propeller, pushes it forward. (For every action, there is an equal and opposite reaction--Newton's Third Law of Motion.) As the propeller is attached to the plane, it pulls the plane through the air.

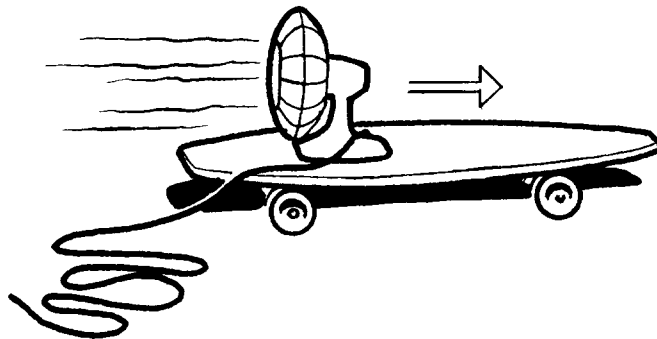

THRUST

Objective: To demonstrate thrust or how a propeller pulls an airplane through the air.

Materials: A balsa wood propeller, a pencil or chopstick

Procedure: Twist a pencil or chopstick tightly into the hub of the propeller. Hold the stick between the palms of both hands, propeller up. Roll it back and forth quickly three or four times and push it forth into the air.

Observations: The propeller, stick and all, fly off into the air and attain good height.

Questions:

1. Does rolling the stick faster help? What happened? (Rolling the stick faster seems to help.)
2. Did you show that your revolving propeller creates thrust? (It took off into the air).
3. Would your class like to try this outside in the wind? What do you think would change? (The wind blowing would be the variable.)

Conclusions: This demonstration shows that a revolving prop creates thrust.

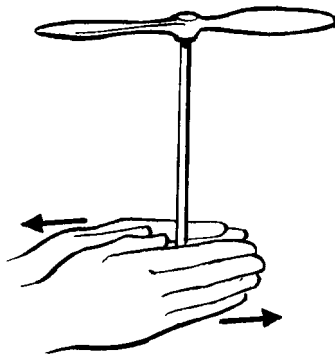

CONTROL SURFACES

Objective: To show how a plane is controlled.

Materials: Folded paper gliders. Use a piece of paper 9" x 6", paper clips.

Procedure: Fold the paper glider by following the steps on the bottom of this paper. Make several until you get one or two that are satisfactory. The finished glider can be held together at the bottom with a paper clip.

Observations: It takes practice to get a good paper glider to work. Also, it takes time to get the clip to balance the glider properly.

Questions:

1. Why do you think some of the gliders didn't go straight? (Bent points, bent wings, etc.)
2. How can this problem be corrected? (Answer varies.)
3. Where did you put the paper clip. What happened? (Put it at the bottom, then moved it around to balance the glider.)
4. The wings and paper clips are called control surfaces on a plane. What might happen to the plane and pilot if these were damaged? (Probably crash.)

Conclusions: Parts on the wings and tail called control surfaces are necessary for controlling the plane's flight.

NOTES: A car can go only right or left, but a plane must be steered up or down as well. It has parts on the wings and tail called control surfaces to help it. These surfaces can be demonstrated by the use of folded paper gliders and balsa gliders.

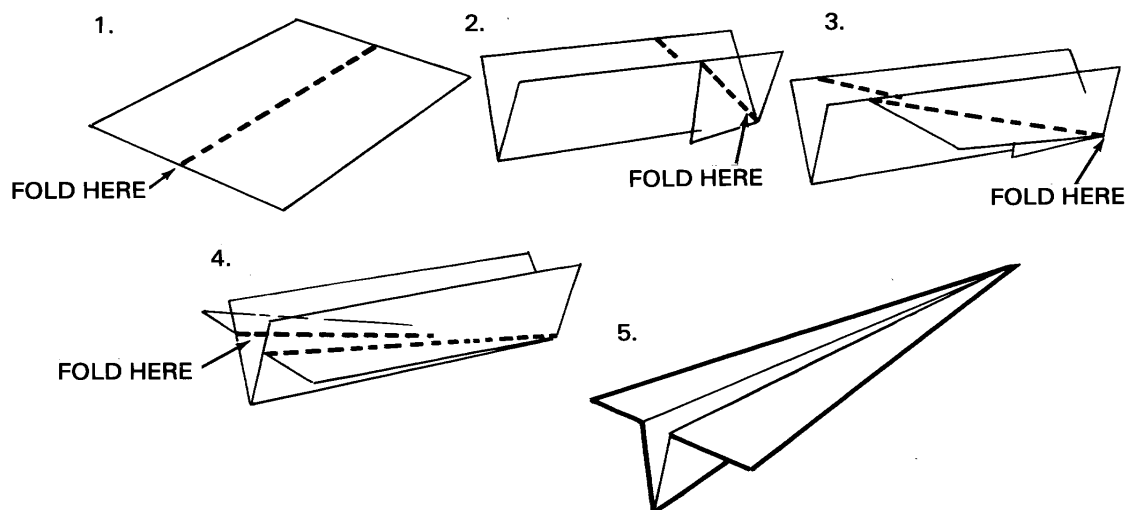

CONTROL SURFACES

Objective: To illustrate the function of control surfaces on a glider.

Materials: A supply of student-made gliders.

Procedure: By folding the control surfaces, the glider will respond to certain directions of flight.

1. Up. Fold the back edges of the paper glider up. When you launch the glider, the tail should go down and the nose should point up. It may take some practice to get the control's set so the glider does what you want it to do. (When the pilot wants his plane to climb, he moves his controls so that the elevators tilt up in the same way that you folded the back edges of the glider. The air hitting the elevators pushes the tail of the plane down, tilting the nose upward, so that the plane can climb.)
2. Down. Fold the back edges of the glider down. (When you throw the glider, the tail should go up and the nose should go down. The same thing may happen when the pilot tilts the elevators downward.)
3. Left and Right. Turn the vertical fin on the glider a little to the right. The glider will fly toward the right. Reverse go to the left. (The pilot moves his rudder to the right for a right turn. But he must also bank his plane for the turn, the same as you would do if you were turning on a bicycle. You would lean to the right for a right turn. The pilot tilts his plane to one side by using the ailerons. When one tilts up, the other tilts down. To tilt the plane to the right, the pilot tilts the left aileron down so the left wing is pushed up. The right aileron is tilted up so the right wing will be pushed down. For a left turn, the pilot reverses the process described above.)

Observations: By adjusting the control surfaces, the glider can go up and down, left and right.

- Questions:
1. What can you do to get your glider to climb? (Tilt elevators.)
 2. How can you get the tail to go up and the nose of the glider to go down? (Fold back edges.)
 3. What should be done to make the glider turn right or left? (Turn vertical fins.)
 4. How does a pilot bank to make a turn? Which control surfaces must he use? (A glider and some planes operate on these same principles. You are operating your glider much the same way a pilot operates his plane.)

Conclusions: Gliders, like planes, are controlled by adjusting the various control surfaces.

CONTROL SURFACES (Cont'd)

NOTES: Control Surfaces. Real planes have segments inserted in wings, in the vertical stabilizer, and in the horizontal stabilizer. These are called the ailerons, rudder and elevator. The pilot moves them into the airstream, then it causes the plane to react to air pressure. The pilot controls their position from the airplane cockpit. By using them he can go to the right or left and also up and down.

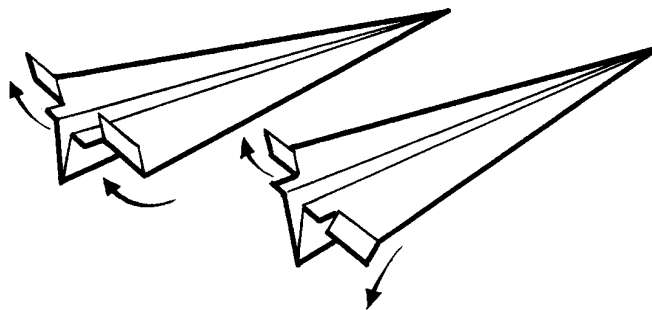
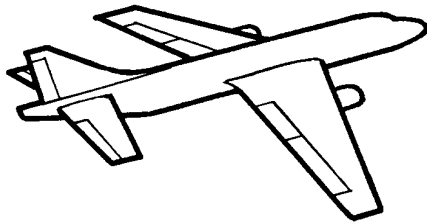

CONTROL SURFACES

Objective: To give examples of the functions of control surfaces using a balsa glider.

Materials: Packaged balsa glider, sheets of paper, glue.

Procedure: Assemble the glider and launch it a few times for practice. Make ailerons, elevators, and a rudder from rather lightweight paper. Glue them to the wings and stabilizers. Now see what you can do with the glider.

Climb	The elevators are up.
Glide or Dive	The elevators are down.
Right Turn	Turn the rudder right.
Right Bank	The right aileron is up, left aileron is down.
Left Turn	Turn the rudder left.
Left Bank.	Turn the left aileron up, right aileron down.

Observations: It takes a lot of practice to make the glider go where you want it to go. The plane rises because of air pressure. Motion is regulated through movement of control surfaces.

- Questions:
1. What is the Bernoulli principle? (The pressure within fluid in motion is lower than the pressure outside the stream; and the greater the speed of the stream, the less the pressure is within it.)
 2. Why does an airplane go up? (Because the pressure on the upper surface of the wing is lower than that on the under surface.)
 3. State Newton's Third Law of Motion. (For every action there is an equal and opposite reaction.) How does this law apply to a plane? (When the pilot moves the control surfaces on the plane, they react to make the plane go in a certain direction.)

Conclusions: The balsa glider is a good way to practice using control surfaces.

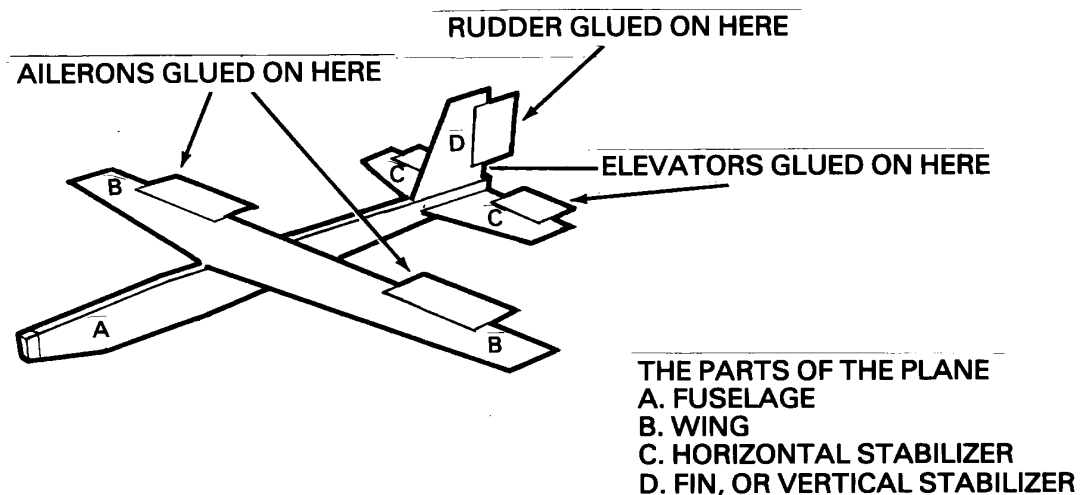

JET PROPULSION

Objective: To demonstrate how a jet airplane works.

Materials: Balloons

Procedure: Blow up the balloon and pinch the neck tightly to keep in the air. Let the balloon go.

Observations: The balloon shoots across the room. The air inside the balloon is pushing in all directions to get out.

- Questions:
1. Did the size of the balloon have anything to do with the distance it went. (The larger ones had more air so they may go farther.)
 2. When you see a jet take off, does it move like your balloon? Where does the air come out of a jet? (Back.) In what direction will the balloon and jet move? (Forward.)

Conclusions: As the air escapes through the open neck it follows the path of least resistance and the air at the opposite end of the balloon reacts in accordance with Newton's third law of motion - to every action there is an equal and opposite reaction.

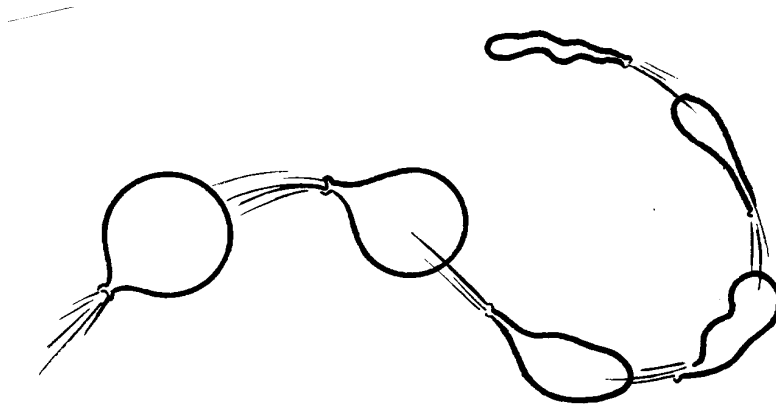

IV. WEATHER IS IMPORTANT TO AVIATION

Weather takes many forms, it may vary from day to day. Changes may also occur rapidly and it is important for pilots as well as other aviation-related personnel to be acutely and constantly aware of even small changes which may affect flying conditions.

Precipitation can take the form of rain, snow, sleet, hail, etc. This moisture comes from the clouds. Observing the sky and classifying the types of clouds along with their movements are most valuable in predicting changes in weather. Wind conditions also are of great importance, they predict weather changes which may affect changes in air routes.

In keeping records, the following categories should be noted: precipitation, air temperature, air pressure, relative humidity, wind direction, wind speed, sky condition, and type of clouds.

To record these observations, different types of weather instruments can be used. For wind, a pinwheel or windmill will show motion. To demonstrate the force of the wind an anemometer can be used. Also, a weather vane will show wind direction. At airports they usually have a windsock. It always swings freely with the wind and shows force and direction to the pilot or observer. Temperature is determined with a thermometer. Changes in temperature may bring about changes in flight plans also, particularly when going from one section of the country to another.

Weather maps which the newspapers compile daily are of great importance to everyone - especially so since the radio and TV broadcasts these changing conditions constantly. Students will be well informed if they are directed to learn about all phases of the weather and how it affects not only their everyday lives but also may be an introduction to a career in aviation as a meteorologist or aviator.

CHARTING WEATHER

Objective: To describe weather conditions which affect aviation.

Materials: Weather calendar or weather charts.

Procedure: Circle each day with colors representing the type of weather, such as orange for sunny, blue for cloudy, black for rainy. Chart the weather for a month, using weather symbols. Record variations in weather during the day. If a storm arises, note how quickly it may have arisen.

Note types of precipitation accompanying hot days/cold days. Note daily cloud formations and their approximate heights above the earth. Note the degree of visibility. Is it affected by haze, fog, rain, or other forms of precipitation, or is it clear? Note types of clouds: cumulus: fluffy, cottony masses; may precede heavy rains and turbulent winds, forecasting colder temperatures; stratus: horizontal layers, may be accompanied by haze, fog, drizzle, or rain, forecasting warmer temperatures. Note force of wind. High winds mean weather changes are coming.

Observations: Day-to-day changes are occurring constantly. Students can keep track of the weather both at school, while at play, or at home.

Notes: The sample list of questions is intended to be used over a period of time. Select the ones most appropriate for the day's lesson.

- Questions:
1. Can you give some reasons why weather is always changing? (The sky and the clouds change, and the sun is sometimes shining and sometimes the clouds cover it, etc.)
 2. Do you think the people who live in Alaska or in Africa can change their weather? Why or why not? (The climate usually remains the same over many hundreds of years, etc.)
 3. Why do different kinds of clouds help in predicting changes? (The kind of clouds give us a preview of what is coming.) How many shapes can you name? (Cumulus, cirrus, stratus, etc.)
 4. Where can you find charts or information about the weather? (Newspapers, radio, television, etc.)
 5. Name some facts you discovered when keeping track of your chart for one month? (We had rain for x number of days; the barometer keeps changing almost every day, etc.)

Conclusions: All personnel connected with aviation flights must be constantly in touch with changing weather conditions.

NOTE: Nimbus has been a term for a rain cloud. However, there are many types of clouds that make rain. Where are they?

Low clouds - 0 to 7,000' approximately

- Stratocumulus
- Stratus
- Cumulus
- Cumulonimbus

Middle clouds - 7,000 to 22,000' (approximately)

- Alto cumulus
- Alto stratus
- Nimbo stratus

(Alto indicates middle)

High above 22,000'

- Cirrus
- Cirrocumulus
- Cirrostratus

(Cirrus indicates high)

Cumulus is Latin for "heap"; cirrus for "hair or curl"; stratus for "layer."

CLOUDS

Objective: To identify simple cloud formations and how they affect the weather.

Materials: Illustrations of cloud formations, notebook and pencil.

Procedure: Observe the sky for two or three successive days. Look out the classroom window for about five minutes each hour. Name and record what was seen each time. Draw pictures of the clouds observed hourly.

Observations: The formation of the clouds matched pictures of various cloud formations.

- Questions:
1. How are the cumulus clouds formed? (Warm air expands as it rises. Then it coils down. The water vapor forms into tiny drops which then collect into a cumulus cloud signaling a cold front.)
 2. Tell about cirrus clouds and how they are formed. (Cirrus clouds tell that a warm front is coming. They are high in the sky. They are formed at high altitudes and contain very small ice crystals. They are not fluffy like the cumulus clouds but are more feathery.)
 3. Do the clouds stay in one place? What happens to them? (They move as the wind blows them away. Sometimes the warm air mass has a great deal of moisture and will form a real high cloud called cumulonimbus which may turn into a thunderstorm.)
 4. Do the cirrus clouds stay in the same location? Where do they go? (The winds blow them away too. They may spread out to a whitish haze. These are called cirrostratus clouds and will bring rain.)
 5. Which kind of cloud would a pilot try to avoid? Why? (High cumulus clouds because they may bring violent weather.)

Conclusions: Small cumulus clouds tell of a cold front approaching but bring good weather. Cirrus clouds tell of an approaching warm front which may bring rain.

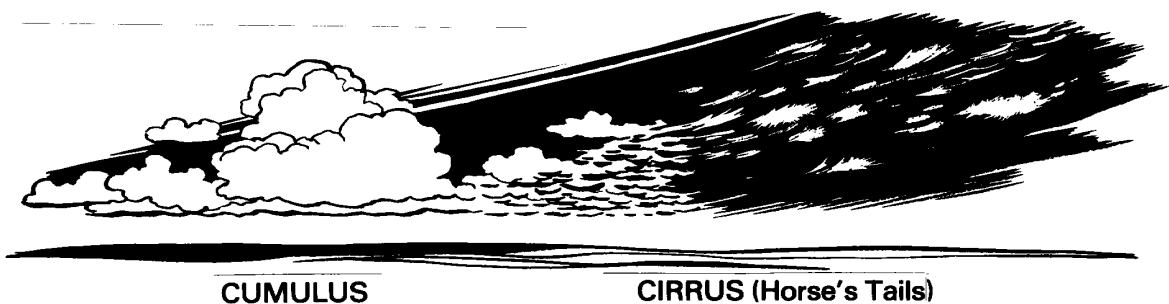

HIGHS AND LOWS

Objective: To demonstrate that a rotating wheel can imitate high and low atmospheric pressure patterns.

Materials: An inflated bicycle wheel.

Procedure: Have a student hold the wheel in a horizontal direction and give it a spin in a clockwise direction. Look down on the spokes moving. Now, give the wheel another spin and get under it to look up. The spokes appear to be moving counterclockwise.

Observation: Looking down, the motion imitates a center of high atmospheric pressure. Looking up, the motion of the wheel looks like a center of low pressure.

- Questions:
1. When you are looking at the earth's surface from below, in the Northern Hemisphere, which way does it appear to rotate? (Counterclockwise; Low.)
 2. When looking at it from the top down, in the Northern Hemisphere, which way does it appear to rotate. (Clockwise; High.)
 3. What effect does the air spiraling away from these highs have? (Brings the tradewinds and stormy westerlies.)
 4. Why should pilots be constantly aware of smaller highs and lows? (The highs and lows move rapidly over great distances and are responsible for much of our day-to-day changes in weather -- which may affect the pilot's course of flight.)
 5. Why does it take less time to fly eastward across the United States than it does for a trip to the West Coast? (Going East, the prevailing westerlies push to plane, while going west, the pilot flies against the wind and it takes longer.)

Conclusions: Atmospheric pressure patterns are very important to a pilot. By noting the clockwise air movement or highs and counterclockwise air movement or lows, the pilot may be able to adjust the flight pattern to avoid problems.

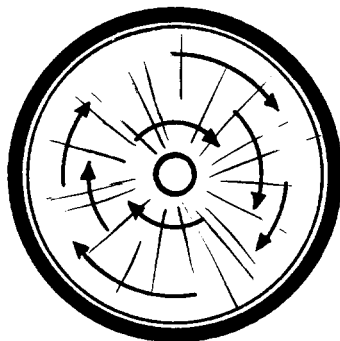

HIGH

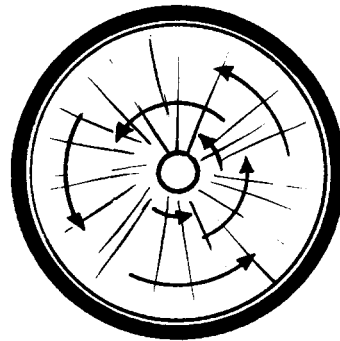

LOW

HYGROMETER

Objective: To make a chemical hygrometer which will show the moisture content of the atmosphere.

Materials: Gum Arabic..... $\frac{1}{2}$ ounce
Cobalt chloride.....1 ounce
Sodium chloride..... $\frac{1}{2}$ ounce
Calcium chloride.....75 grains
Distilled water.....1 ounce

Small doll with cotton skirt, cardboard, cotton cloth, rabbit pattern.

Procedure: Mix the chemicals into one solution. (Use a glass beaker.) Dress a small doll with a skirt of cotton cloth treated with the freshly mixed solution.
Cut out the cardboard rabbits and place them on large cloth ears treated with this formula. (To treat, dip cloth into solution, let dry.)

Observations: The cloth will turn blue only, clear days; lavender on days when weather is changing; and pink when it is raining or the humidity is high.

Conclusions: The doll or rabbit when treated with the chemical solution, will change colors to show the change in moisture content of the air.

Notes: Chemicals used in this experiment are inexpensive and are available from chemical supply houses.

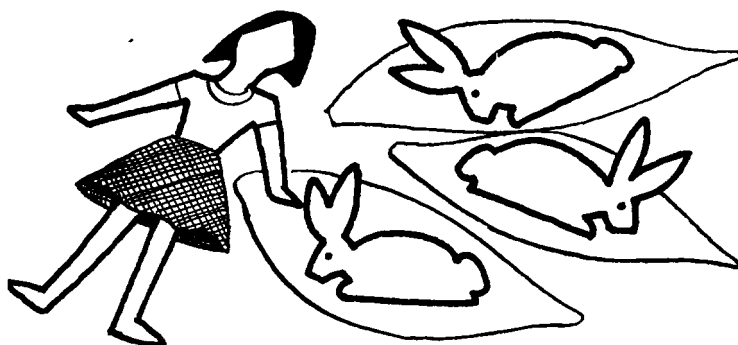

WATER/ICE

Objective: To find what happens to water when the temperature goes below 32°-F.

Materials: Glass bottle, preferably tall and thin screw cap, water, masking tape.

Procedure: Fill the bottle to about an inch from the top and mark water level on the outside with masking tape. Put the bottle outdoors in the shade if the day is very cold -- below 32°F. If the day is warmer than 32°F, put the bottle, standing upright, in the freezing compartment of a refrigerator. Observe what happens to the level of water as ice crystals begin to form in it. Note the change in the level when the water is completely frozen.

Observations: Ice crystals begin to form at the top. When the water is completely frozen, the jar is full because ice expands.

- Questions:
1. What happened when you fill the container too full? (The liquid expands when it freezes and comes up.)
 2. Did you ever put a glass soda bottle in the freezer? What happened to the contents and bottle? (The bottle cracked and the liquid spilled out in the freezer and froze.)
 3. In this experiment what happened to the bottle that was put in the freezer? What caused the change? (The level rose as the temperature dropped. This was caused by expansion.)
 4. Where did the ice crystals start to form in the bottle? (At the top of the liquid.)
 5. Where do the ice crystals start to form in a pond or lake? (At the top of the water, the surface.)
 6. Why don't fish freeze to death during the winter in the lake? (Because the water below the surface is not frozen.)
 7. What is the freezing temperature of water? 32°F.
 8. What happens to rain at 32°F? (It turns to snow or ice.)
 9. How does the weather change when the temperature drops? (It gets much colder.)
 10. Why are pilots fearful of sudden drops in temperature especially during the winter months? (Because ice may form on the ailerons and other control surfaces and make them immobile.) (Ice forming on the top of an aircraft wing can reduce the amount of lift by the wing.)

Conclusions: Weather is determined by the surrounding temperature. When the temperature is below 32°F, snow and ice will form.

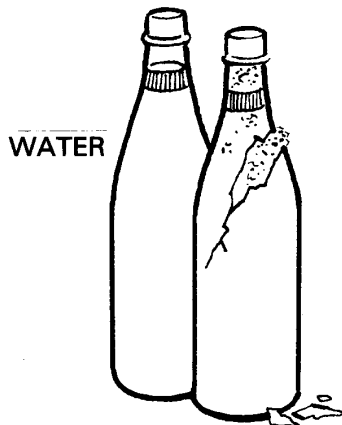

WIND HAS FORCE

Objective: To show that wind has force using a windmill.

Materials: Pinwheel, small frozen juice can (empty, clean), 9" x 9" piece of paper, scotch tape.

Procedure: Wrap the paper around the can. Fasten it with tape. Insert the pinwheel shaft through the paper covering near the top. Place the completed windmill in an open window so that the blades will catch the breeze.

Observations: When the wind is blowing, the windmill will turn.

Questions:

1. Did the windmill catch the wind right away or did you have to move it? What direction? (Toward the wind.)
2. Have you ever seen a windsock at a small airport? (Describe it as a sock flying in the air.) (It shows the direction of the wind. If the force of the wind is strong, the sock will be horizontal. The windsock looks like a sock without the heel, and is mounted on a tall pole.)

Conclusions: The windmill turns because wind has force.

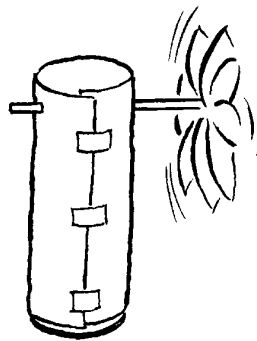

THE ANEMOMETER

Objective: To show how wind may vary in force using an anemometer.

Materials: Reinforced paper cups, dowel stock, 2 glass beads, 2 thin wooden sticks, 18" x 1/2"

Procedure: Attach the cups to two crossed sticks, so that all are heading in the same direction. Join sticks to dowel stock as follows: Nail, bead, crossed sticks, bead, dowel stock. Beads will act as bearings so the wind will turn anemometer freely.

Observations: The spinning is faster as the force of the wind increases.

Questions:

1. Where is a real working anemometer located? (at an airport, maybe on top of a high school, possibly at the local college.)
2. Why is it in that location--who uses it? (It is located there because there is lots of wind. The pilot looks at it, the students look at it, the college students study weather.)
3. What makes a windmill work? (The winds are strong and make the blades on the windmill rotate.)
4. Why does the country of Holland use so many of them? (To control the supply of water from the Atlantic Ocean and also for control of their dikes.)
5. In the United States, many large windmills are used to pump water for irrigation. What other uses are windmills used for? (To generate electricity, etc.)
6. When the wind dies down the vanes on the windmill do not go around, and the cups on the anemometer do not run. At that time you can see with your eyes the force of the wind.
7. How would you calibrate this anemometer? (Count revolutions per minute on two different days. Compare wind speeds.)

Conclusions: The anemometer shows how wind may vary in force.

Notes: The school flag outdoors on the pole may hang limp when wind of little force is present or be blown about by winds of greater force.

Methods of Calibrating the Anemometer

1. Count the number of turns it makes per minute in a wind of known velocity as reported by the weather bureau. Dividing the number of revolutions per minute by the number of miles per hour will give you the number of turns per minute the anemometer will make for each mile per hour of wind velocity.
2. The anemometer can also be carefully held out of a car window when the car moves at 20, 30, 40, 50 miles per hour and count the number of revolutions for each of the velocities. (This should be done on a day when there is no wind blowing.)
3. With the wind blowing, count how many times the anemometer spins around in 30 seconds. Divide the number by five and this will give the approximate velocity of the wind in miles per hour.

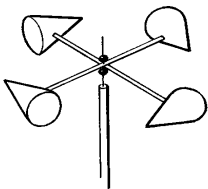

WEATHER VANE

- Objective: To show that wind has direction, using a weather vane.
- Materials: Feathers, straight pins, soda straw, new pencils with firm eraser.
- Procedure: Insert a 6"-8" feather in one end of the straw, gluing lightly. Find the balance point by holding the straw on extended finger so it will not tip; insert pin at this point and stick pin into the eraser. Fasten the pencil to a post outdoors where the vane can swing freely.
- Observations: The vane moves with the wind, always pointing in the direction from which the wind is blowing.
- Questions:
1. Did the vane work the first time? What did you have to do to make it work? (Had to find the balance point more carefully, then stick in the pin).
 2. Did most of the vanes point in the same direction? Why or why not? (The ones that did not might have been tipped over or in a different path of the wind.)
 3. Do you think your vane will hold up under a strong wind? How could you make it more sturdy to study wind direction? (Use stronger materials.)
- Conclusions: A feather weather vane is a good indicator of wind direction.

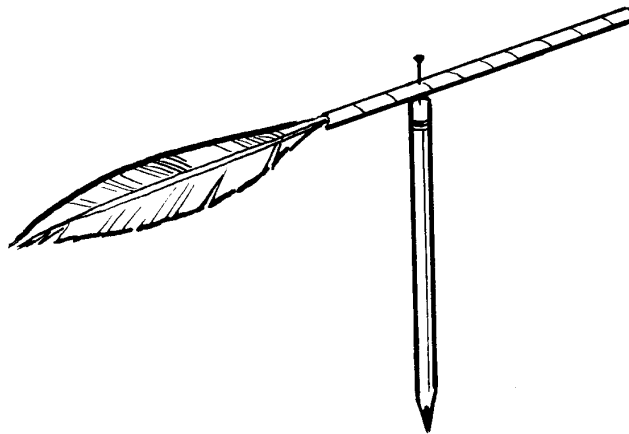

THE THERMOMETER

Objective: To show how a thermometer measures temperature.

Materials: Stiff white paper, about 10" x 3", narrow white ribbon about 18" long, red ink, scissors, rulers.

Procedure: Dip about half the length of the ribbon into the ink, let it dry. Make a cut in the paper 1/2" above and another 1/2" below the space from which the strip was cut. Make these gashes slightly longer than the width of the ribbon. Insert the ribbon, with the red half toward the lower end of the paper. Mark the paper in degrees of temperature to cover the range expected in the classroom, or wherever the thermometer will be used, to agree with a real one -- from 50°-90°. Pull the ribbon up or down to register the proper temperature.

Observations: The paper thermometer gives an understanding of degrees of heat and cold. When assembled it serves as a starting point for learning the common and necessary temperature reading skills.

Questions:

1. How many thermometers do you have in your house? What kind are they, and where are they kept? (Fever thermometer, bathroom cabinet, thermostat, dining room, outdoor thermometer, outside the door.)
2. Temperature is marked in degrees. Are your degree markings measured very carefully? (Check each student while using the ruler to ensure accuracy.)
3. How does temperature affect the airplane in flight? (Cold air can cause icing on the wings, variation in temperature can cause turbulence, etc.)
4. How does the temperature change when the pilots fly high above the earth? (Gets colder the higher up they go.)

Conclusions: The degree of hotness or coldness of the air around us is called temperature. Since the atmosphere and the earth receive their warmth from the sun, this warmth may vary from place to place and from day to day. By using a thermometer, we are able to accurately record temperatures. Temperature affects the ability of an airplane to fly.

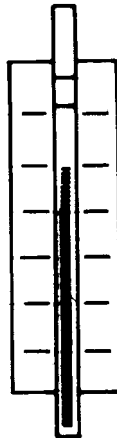

THE ANEROID BAROMETER

Objective: To examine an aneroid barometer and explain its action.

Materials: A working barometer and a picture of the inside working parts.

Procedure: Aneroid means without liquid. The barometer is enclosed in a small disk-like metal box. Part of the air has been removed. When the atmospheric pressure increases, the top of the small box is depressed. If the pressure decreases, the top of the box rises. The movement of the top of the box is sent to a needle on the dial. The scale shows the pressure in inches of mercury. The light colored pointer tells the pressure. The black pointer is set by hand over the light one by the knob in the center. This shows whether the pressure is rising or falling.

Observations: The hand moves to the right or to the left depending on advancing changes in the weather. The hand needs to be moved to coincide with the light colored pointer each time there is a change.

Questions:

1. What function does an altimeter serve in an airplane? (The common type of altimeter that is used to indicate altitude is really an aneroid barometer.)
2. Do you have a barometer in your home? If so, observe and report on the movement of the needle on the dial.

Conclusions: An aneroid barometer records barometric pressure accurately. It is a good weather forecaster. An airplane needs an altimeter to help the pilot read his altitude correctly and to be able to correct for ground elevation changes.

The mechanism of an aneroid barometer. The top of the hollow evacuated box, H, moves up and down with changes in pressure. The box is kept from collapsing by the piece of spring metal, A, fastened to the base, B. The arm, G, fastened to A moves about a pivot, and the arm, F, which is fastened to A moves the chain, E, back and forth. This chain is wrapped around the axle, D, and held taut by the hairspring, C. A pointer (not shown) fastened to the end of the axle, D, moves across a dial (not shown) to show the rise and fall of the pressure. The combination of arms, pivots, and levers is necessary to amplify the motion of the box and to give an easily visible movement of the pointer for small pressure changes.

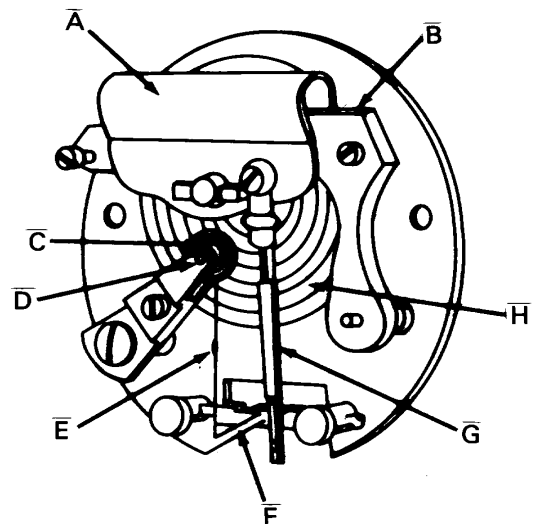

MAKE A BAROMETER

Objective: To show how a "home-made" barometer can be used to measure air pressure.

Materials: Glass jar with wide mouth (pickle jar is good), balloon, soda straw, rubber cement or glue, match (for the wood), 5 x 8 cardboard with the 5" side attached (glued) to the small wood block, rubber band.

Procedure:

1. Make a barometer: Cut out the domed part of the balloon and stretch the rubber tightly across the mouth of the bottle. Secure tightly with a rubber band. Flatten both ends of the straw and cut one of the ends to a sharp point. Place glue on the flattened end and attach it to the middle of the rubber of the balloon. Cut a piece of wood from the match and glue it at the end of the rubber sheet so that the straw rests on top of the wood.

Observations:

1. Have the students observe and record where the straw points on the 5 x 8 card. Make some marks on the card so they can observe if the straw goes up or down.
2. When air pressure increases, the rubber sheet is pushed down and thus the straw moves up . When the air pressure in the room decreases, the greater air pressure inside the bottle now pushes the rubber sheet up, making the straw move down.
3. Keep the barometer in the same place and take readings over the period of 2 weeks. indicate to students that these readings are the way meteorologists measure the highs and lows of the air pressure.

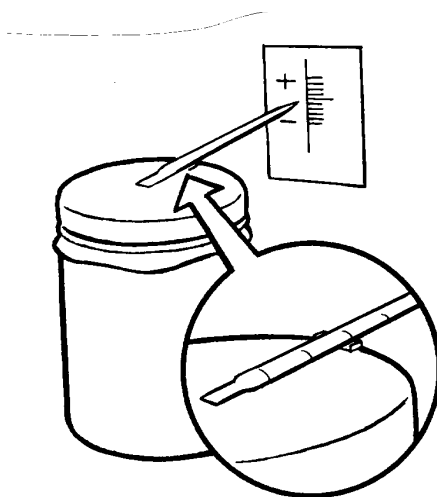

MAKE A BAROMETER (Cont'd)

- Questions:
1. How can meteorologists measure the highs and lows of air pressure with this simple instrument? (Watch to see if the straw moves.)
 2. What happens to the rubber sheet when air pressure increases? Will the straw go up or down? (Up.)
 3. What happens to the rubber sheet when the air pressure decreases? Will the straw go up or down? (Down.)

Conclusions: Meteorologists can measure the changes in atmospheric pressure, that is the highs and lows of the pressure, by using an instrument called a barometer. (The device here is an example of a very simple aneroid barometer.)

DEW POINT

Objective: To determine the moisture in the air by use of the dew point.

Materials: Polished aluminum water glass, crushed ice or small ice cubes, room thermometer, water, dry ice, tongs, asbestos gloves.

Procedure: Fill the glass one-half full of water at room temperature. Make sure the glass is dry on the outside. Place the thermometer into the glass. Add ice slowly, carefully noting changes in the temperature of the water and watching for condensation (tiny drops of water that occur on the outside of the glass.)

TEACHER DEMONSTRATION ONLY FOR THIS PART!

Repeat the experiment, using dry ice (CO_2) instead of ice cubes. Note "frost" forming on the outside of the glass.

Repeat both parts of this experiment on different days and record results.

Questions:

1. What began happening after the ice cubes were added to the water? (Condensation began.)
2. Did the temperature change on the thermometer? How? (Yes, the temperature reading went down as it cooled.)
3. What happened to the outside of the glass when dry ice was used? (Frost formed.)
4. What is the difference between condensation and frost? (Water drops and ice crystals.)
5. Why was the reading on the thermometer important to show the dew point? (When the water became cold enough, the air became saturated with water vapor and began to condense.)

Conclusions: Dew point is the temperature at which the air becomes saturated with water vapor and the relative humidity becomes 100%. This experiment demonstrates dew point.

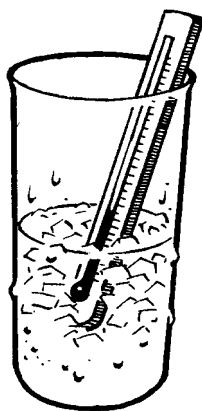

THE SUN

- Objective: To show what happens when light rays strike a surface.
- Materials: Flashlight, paper tube large enough to fit around flashlight, large sheet of paper, table, protractor.
- Procedure: Lay the paper on the table. Tape the paper tube around the flashlight. Turn on the flashlight and direct its rays straight down on the paper. Draw circle on the paper around the outline of light. Notice brightness of the reflected light. Now hold the flashlight at a 45°. Draw around the light reflected on the paper and notice its brightness. Compare the area of the circle with that of the oval.
- Questions:
1. How does the brightness compare when the flashlight is tipped at a 45° angle? (Not quite as bright.)
 2. What pattern is formed this time? (Oval.)
 3. Why is it so hot where we live, in the summer? (Direct rays give off more heat.)
 4. If the sun is closer to the earth in the winter, why is it so cold in the winter? (Rays from the sun comes in at an angle, giving less heat.)
 5. How does the area of the circle compare with that of the oval you drew? (Circle has smaller area--direct rays.)
 6. If a pilot flies from the summer season location, show where he might land where it would be the winter season. (Use a globe to locate these areas.)
- Conclusions: The sun gives more heat in summer because light rays come directly from their source. It is not summer everywhere on earth at the same time because the sun's rays will be on an angle in some places while straight down in others. An airplane can fly from one season to another in a matter of hours. The pilot must be able to adapt to the different seasonal conditions.

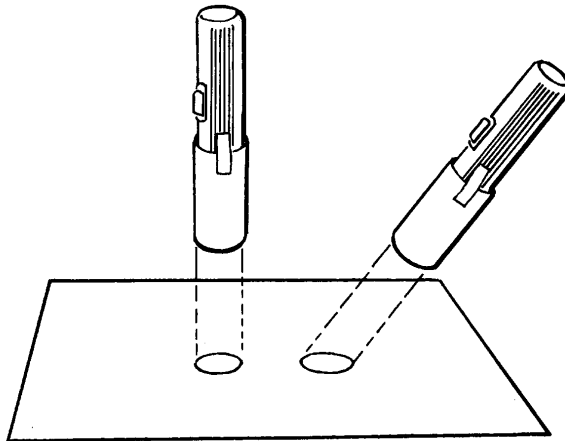

NIGHT, DAY, TIME ZONES

Objective: To compare changes in time zones using a globe

Materials: Globe of the world, flashlight. (Use a basketball, grapefruit, or balloon, as a substitute globe.)

Procedure: Point the lighted flashlight in the direction of New York City on the globe. This side of the globe represents daylight; the opposite or dark side represents nighttime. (When it is twelve noon in New York City, it is midnight in Bangkok, Thailand.) Turn the globe so that the positions of New York City and Bangkok are reversed. What time is it in Bangkok? In New York City? Locate various other time zones.

Observations: The sun is shining all the time on some part of the earth. (When we look at the moon, we see reflected sunlight.) When the sun is shining on New York City at noon, it is midnight in Bangkok.

Questions:

1. Where does the sun go when it sets along the horizon? (It is beginning to shine on another part of the earth.)
2. Which is turning -- the sun or the earth? How do you know? (The earth is turning. The sun stays in the same position.)
3. Do you know why the moon shines so brightly in the sky? (Reflected light from the sun.)
4. Why do airplane passengers need to change the time on their watches when going around the world? (The time zones change.)

Conclusions:The sun gives light all the time. Day, night, and time zones change with the position of the sun as the earth turns.

Comparative Time

SAN FRANCISCO
AM

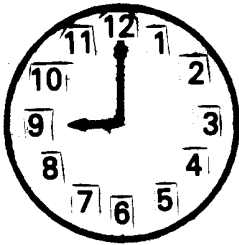

NEW YORK
NOON

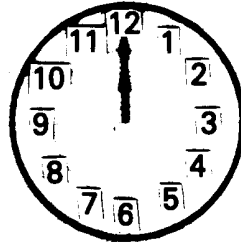

BERLIN
PM

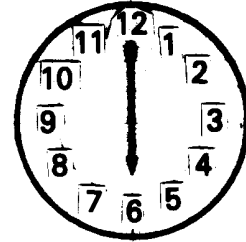

BANGKOK
MIDNIGHT

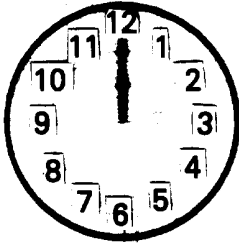

YOKOHAMA
AM

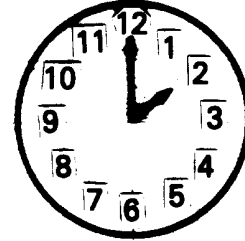

HEAT ENERGY

Objective: To show how heat energy can cause an object to move.

Materials: Paper, pencil, straight pins, scissors, 5" pieces of thread, a lamp and bulb.

Procedure: Turn on the lamp. Trace the spiral on a sheet of paper. Make a pinhole in the center of the spiral. Cut the paper into a spiral strip. Put the thread through the pinhole and tie a knot. Hold the thread so that the spiral is about 1/2" above the light bulb.

The spiral should begin to turn when it is placed over the lamp. Spirals can also be held over a radiator or in other parts of the classroom to find movements of air currents. Have students cut spirals of different sizes and repeat the activities. Have them cut another set of spirals in the opposite direction and check out their results.

- Questions:
1. Did the spiral move when you turned the lamp on? How could you improve this movement. (Try holding the spiral closer to the lamp to get more heat.)
 2. What happened when you cut a spiral in the opposite direction? (Will rotate in the opposite direction.)
 3. Do small sizes work differently than large spirals? Tell us what happened. (Answers will vary.)
 4. Why does a hot air balloon rise? (Because of heat energy from the lamp.)
 5. Can you relate heat energy to the movements of a hot air balloon, and a sailplane? (Hot air balloons get their heat from a blowtorch which can be regulated, sailplanes go up and down according to the thermal energy from the sun heating up the air.)

Conclusions: Heat energy given off by the lamp made the spirals move.

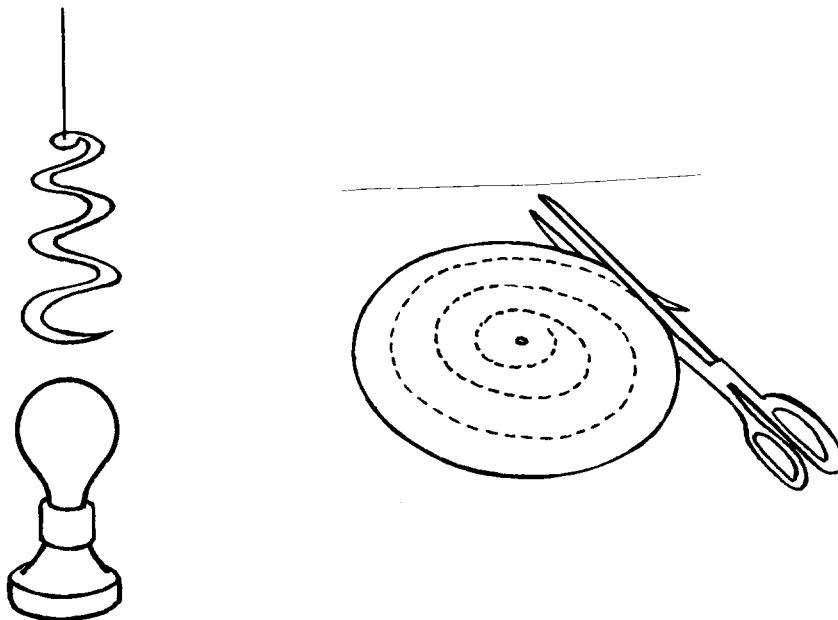

COLOR AND TEMPERATURE

Objective: To show how color affects temperature.

Materials: 2 soup cans, heat lamp, 2 thermometers, water, black spray paint, hot plate.

Procedure: Remove lids and labels from each can.
Spray one of the cans with the black paint and let dry.
Fill both cans with cool water.
Place them over a warm radiator, in warm sunlight, or in front of a heat lamp.
After 15 minutes, record the temperature of both cans.

Next, put the same two cans in a protected place away from air drafts. Fill them both with hot water (not boiling). Record the temperature 15 minutes later.

Observations: In the first experiment the water in the dark can was warmer.
In the second experiment the water in the dark can was cooler.

Questions: Explain how color affects temperature (the black can will absorb more heat than the silver can).
The black can will also lose heat more rapidly).

Conclusions: Color is a factor that can affect temperature.

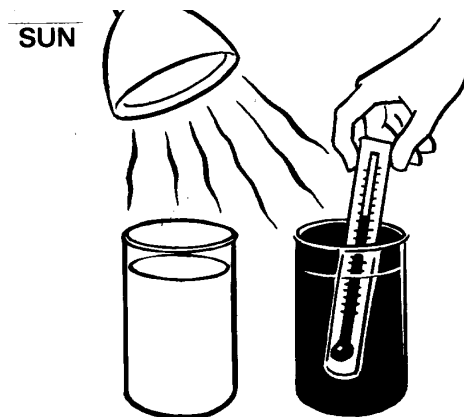

V. NAVIGATION IN THE AIR

In order to go from one place to another you must be able to accurately locate your present location and then pinpoint where your destination is. We use maps which include various legends, direction, latitude and longitude, scale of miles, lines for divisions of states or countries, etc.

When airborne, our senses and alignment changes. In the sky you see land without boundaries, and you look for familiar landmarks, such as a river, lake, forests, etc. If you go up even higher, you will see that our earth is a globe. When you travel great distances in a plane, such as overseas, day may turn into night. You may be either following the sun's path or going in the opposite direction. A pilot must know if the direction she/he plans to travel will go towards the daylight or whether the route will go into pitch darkness which requires even more skill in navigation and instrumentation. There, navigation in the air is concerned with the earth's rotation around the sun.

A compass is a vital necessity for every pilot. Knowledge of key stars particularly the North Star, which is used primarily by navigators at sea and also in the air--assists in determining the plane's bearings accurately and keeps it safely on course. Knowledge of astronomy is vital especially for flights covering great distances and many countries.

Navigators are greatly helped when airborne by receiving satellite signals. These are very accurate and extremely helpful when interpreted properly. Pilots also use satellites to pinpoint their location. Another instrument used is a sextant. Today navigators in the air "shoot the sun" and thereby they can confidently determine their exact latitude and relay this information to the pilot.

THE EARTH ROTATES

Objective: To show how the rotations of the earth causes day and night.

Materials: Large globe, flashlight, small toothpicks, small markers (stickers).

Procedure: Attach the colored marker to the toothpick and tape it to the globe. Place it where your city is located. Shine the flashlight on the slowly rotating globe.

Observations: The shadow changes on the marker. You can see day and night appear. The globe has to be turned carefully to get the effect of day and night on the tiny marker.

- Questions:
1. What direction is the light coming from when you make your shadow in the classroom? (Hold the flashlight above and behind person until shadow becomes visible on the wall or board).
 2. What happens when the light hits the marker on the globe? (First you see light, then you see a shadow).
 3. As the globe rotates very slowly does the shadow change on the marker? (It falls on the marker and then moves on to other parts of the globe).
 4. Can you see day and night appear? (The light shining brings daylight, and on the dark side of the globe is night time).
 5. In order for a pilot of a plane to stay in the daylight for a whole day, which direction should he travel? (As the world turns--counterclockwise).

Conclusions: By slowly turning the globe, one side becomes light and the opposite side becomes dark, demonstrating day and night.

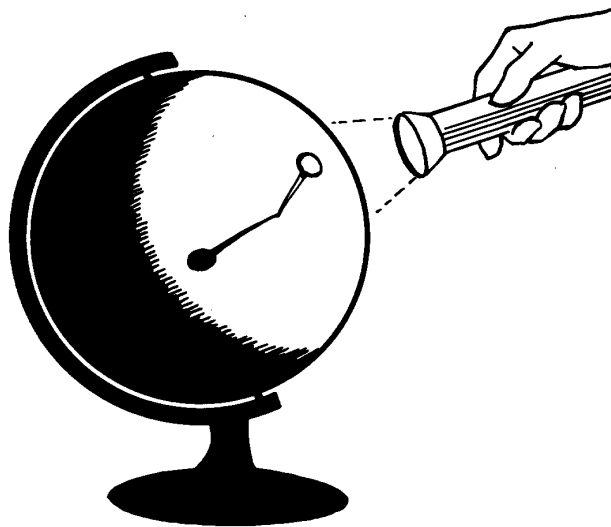

THE COMPASS

Objective: To make a simple compass.

Materials: Strong magnet, sewing needle, 2 small corks, glass container, water.

Procedure: Stroke the needle with the magnet from the center outward at least 10 times.
Reverse the magnet. Reverse the needle. Stroke again from center outward at least 10 times.
Push the needle into the corks.
Place the compass into the water in the container. (Keep container away from metal objects).

Observations: The needle moved in the water and lined up north and south.

Questions:

1. Why was the needle stroked with the magnet? (To magnetize it).
2. Why were the needle and magnet reversed? (To change the polarization).
3. What happens if the magnet is dropped? (It loses its magnetic powers).
4. What purpose did the water serve? (It allowed the compass needle to move freely).
5. Why did the needle point in a north-south direction? (It was lining up with the real north and south magnetic poles of the earth).
6. If you had a metal object near the compass, what would happen? (The needle would point toward the object, and not be useful as a compass).

Conclusions: A compass is a necessary instrument for the pilot to use in locating landmarks.

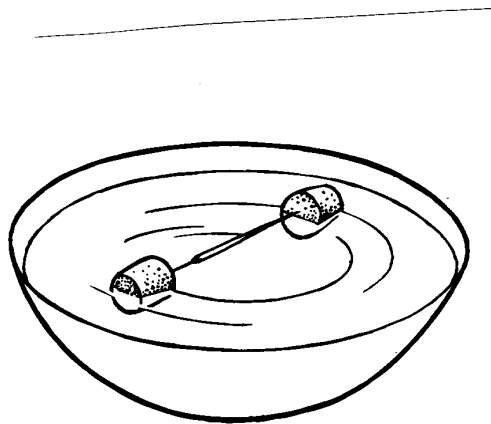

THE DIPPING NEEDLE

Objective: To assemble a dipping needle.

Materials: Steel knitting needle, 2 sewing needles, 2 water glasses, a natural cork, strong magnet.

Procedure: Stroke the knitting needle at least 20-30 times, in one direction, with the magnet.
(Soak the cork in water overnight to make it less brittle).
Push the knitting needle carefully through the center of the cork.
Carefully push the needles into the sides of the cork.
Line up the glasses in an east-west position.
The knitting needle should be balanced on the glasses in a north-south direction, so it can swing freely. (Be careful to prevent it from dropping on the desk).
Move some objects nearby the dipping needle to see the reaction.

Observations: The magnet will dip in the north-south direction.

Questions:

1. Why is a strong magnet needed? (To cause the electrons to move through the thick metal of the knitting needle).
2. Why were brand-new sewing needles used right out of the package? (To make sure they were unmagnetized, so as not to interfere with the magnetized knitting needle).
3. Was direction of the glasses important? (Yes. They were placed in a east-west position so that the swing of the knitting needle would not be affected).
4. What effect would there be if the set-up fell onto the desk? (The knitting needle would lose some of its magnetic force and would have to be stroked all over again).
5. What objects did you bring near the dipping needle and what happened? (A tin can and a large nail caused the needle to move, but a plastic comb caused no change, etc.).

Conclusions: A dipping needle will help to find the direction of the magnetic lines of force for any place on earth. It is like a compass and can help a navigator maintain the correct position during the flight.

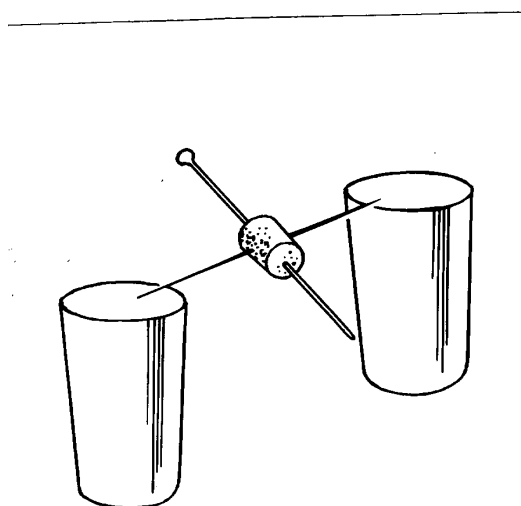

LOCATING COORDINATES

Objective: To correctly plot coordinates on an outline map and globe

Materials: Copies of a World Coverage Outline Map, ruler, pencil, eraser, Atlas for student reference, globe.

Procedure: Show students how to use an Atlas. Describe the latitude and longitude lines. Also, point out a few major cities and how to find exact location using both latitude and longitude coordinates. Put the map flat on the desk and use the ruler to go across to the preselected latitude given. Draw a faint line across the map in pencil. Then use the ruler to go up or down to the longitudinal coordinate. Again, draw a faint line straight across. Where the two lines intersect, mark the point. Then use the Atlas to see if there is a city at that location. Continue plotting coordinates as listed.

Observations: Locating points on the map takes accuracy and patience.

Questions:

1. What are the coordinates of the place where you live? (Answers will vary.)
2. How does the flat map differ when you locate the same coordinates on the globe? (At the polar regions the longitude spaces get narrower, and the equator line at 0 goes all around the globe. Answers will vary.)

Conclusions: With coordinates you can accurately locate any point on earth.

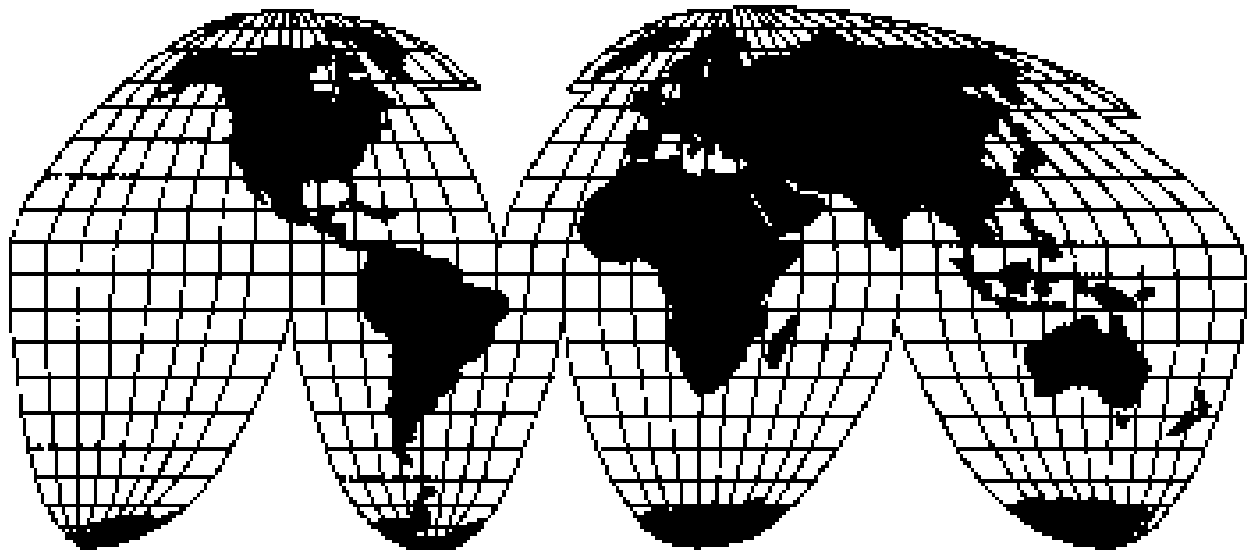

Word Coverage Outline Map

SATELLITE SIGNALS

Objective: To use signals from a weather satellite to pinpoint locations.

Materials: Squared paper, pencils and erasers. A series of coordinate directions.

Procedure: Mark paper with coordinates as shown on diagram, including starting point.

Follow given directions to move your pencil the correct number of squares and location as written. Note the signal picture.

Find the starting point 5 squares down and 7 squares from the left. Move the pencil in the direction and the number of squares indicated.

3W, 1NW, 2E, 3N, 2SE, 2W, 1S, 3E, 1SW

Design your own picture by calling out new directions to your partner.

Observations: By following directions a satellite picture was drawn.

- Questions:
1. How do the signals get back to earth? (Satellites take pictures. These are scanned by a beam of light and changed into a radio signal. The radio signal comes to earth and is then converted back into a picture.)
 2. Why were NE, SE, NW, SW, added to the graph? (To make a more accurate description of the location possible.)

Conclusions: Weather satellites can be used by pilots and navigators to locate their positions accurately and quickly.

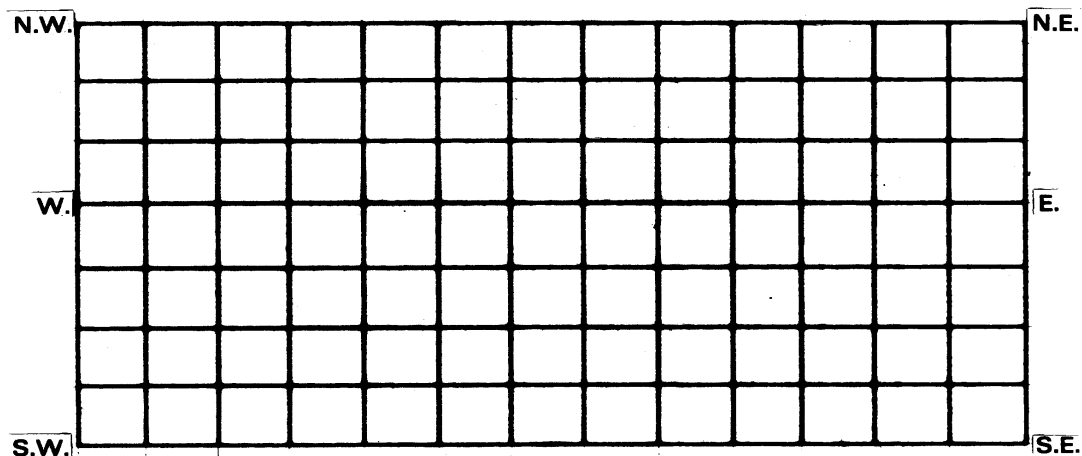
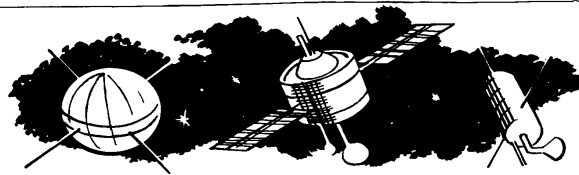

SATELLITE SIGNALS

Objective: To plot satellite radio signals.

Materials: 2 sheets graph paper (15 x15 squares), 2 pencils.

Procedure: This experiment needs one student as "satellite" and the other as a "receiving station".
Satellite student will draw a picture on graph paper by filling in some of the squares. Fill in each square entirely.
The satellite student then scans the picture beginning in the first square (left) in row #1, and goes across square by square to the last square in row #1.
The scan then moves to the first square (left) in row two and scans that row.
As each row is scanned, if the square is empty, the satellite says "zero", aloud. If the square is filled in, the satellite says "one", aloud.
The ground "receiving station" student, listens, and follows the scan and marks the graph paper. Every time the word "one" comes up, the square is entirely filled in.
At the end of row 15, the two pictures are compared.

Observations: Either the two pictures are identical or variations are noted.

Questions:

1. Why did the "satellite" student draw the picture on graph paper? (Because he has to pretend these are photographs actually taken.)
2. What code did the "receiving" student use? (A two number code, 0 and 1.)
3. Is there a difference between the satellite picture and the receiving station recording? (Discuss.)

Conclusions: Radio signals can be translated and plotted to make a picture.

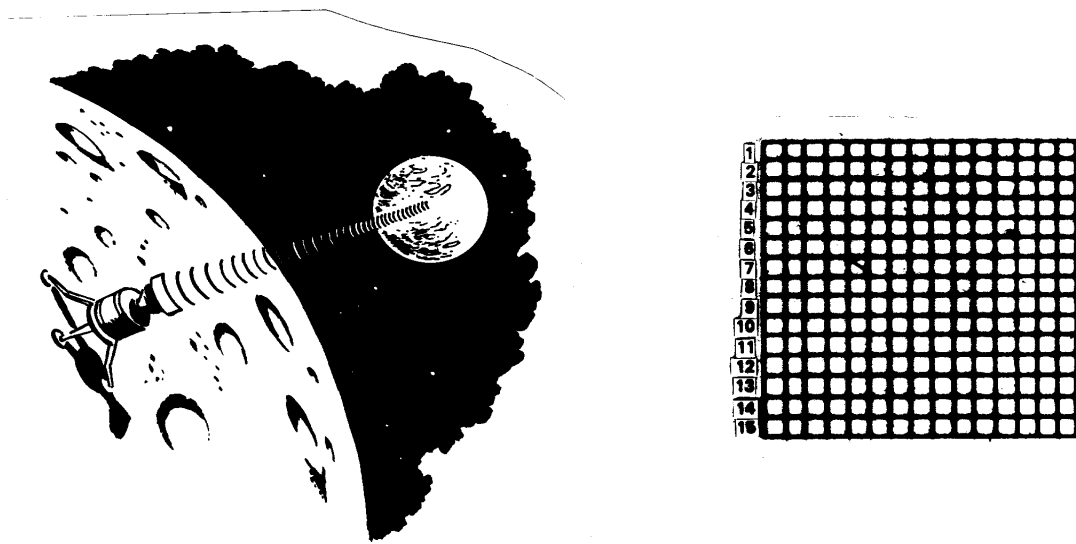

LATITUDE AND LONGITUDE

Objective: To relate points on a circle to the face of a compass used for determining direction.

Materials: A metal compass, protractor, paper, pencil, a store compass, ruler.

Procedure: Using the metal compass, draw a large circle on the paper.
Use the ruler to draw vertical and horizontal lines through the center. Mark north, south, east, and west at the intersections. The N will be 0° . The S will be marked 180° . E will be 90° and W will be 270° .

Use the protractor to mark off points every 30° around the circle.

Point to where a variety of angles would be, such as 30° , 45° , 60° , 120° , etc., all around the circle.

Observations: The complete circle contains 360° .

Questions:

1. How many degrees are there from N to E? (90°); from N to S? (180°).
2. What additional markings does the compass card show? (NNE, NE, ENE, etc.)
3. Would these markings be valuable in navigation? How? (Gives more accurate location and direction.)

Conclusions: A circle that is marked with N, S, E, W, and degrees can be used as the face of a compass for finding direction.

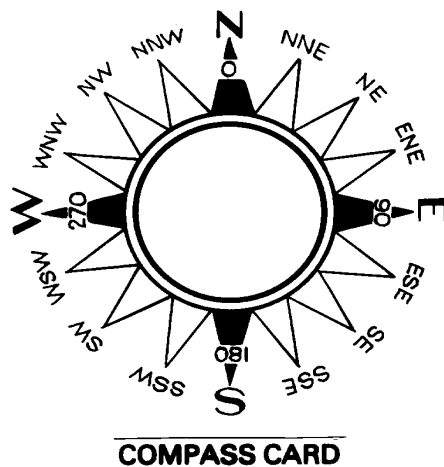

LATITUDE AND LONGITUDE

- Notes: The distance in miles per degree of longitude varies from a maximum of about 70 miles at the equator to zero at the poles. A degree of latitude at the equator is equal to about 68.7 miles; at the poles it is about 69.4 miles.
- Objective: To discover how latitude and longitude are determined.
- Materials: Modeling clay, table knife, compass, protractor, filing card, scissors, ruler, paper clip, waxed paper.
- Procedure: Form a ball of modeling clay 2 or 3 inches in diameter. Make it spherical by rolling it on the waxed paper on the desk. Cut out a quarter section as shown in the diagram. On a filing card, draw a circle of the same diameter as that of the ball. Measure off angles of 15° degrees with a protractor and cut out the disk as shown in the diagram. Fold the disk along a diameter and fit it in the cut out portion of the ball as shown in the diagram. Mark the meridians and parallels on the ball in the positions determined by the points where the sides of the angles meet the surface of the ball. Use a paper clip for marking the clay.
- Observations: The arc on the surface is related to the central angle.
- Questions:
1. Point out the North and South Poles and the Equator on the clay ball.
 2. Why are meridians also called longitude lines? (Because they are "long", they go from the North Pole to the South Pole.)
 3. Why are parallels also called latitude lines? (Because they are each parallel around the clay ball from the North Pole to the South Pole, like slices of an orange.)
- Conclusions: Latitude and Longitude are measured in 15° angles around and up and down the globe of the earth.

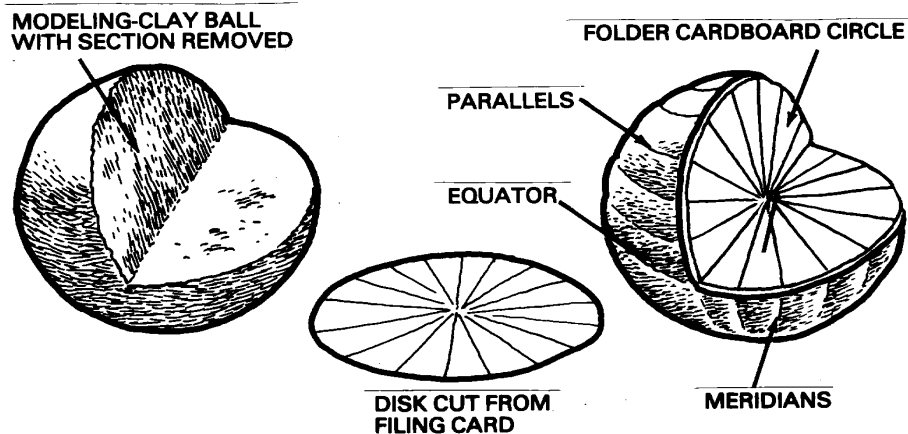

THE SEXTANT

Objective: To measure latitude using a sextant.

Materials: Cardboard protractor, straight stick, thumbtack, thread, large nail.

Procedure: Fasten protractor to stick with thumbtack as shown in diagram. Secure nail to the thread and attach it under thumbtack, also making sure it can swing freely. This is the plumb line. Sight along the top of the stick to the North Star at night or to the Sun during the daylight hours. See diagram. When the North Star or Sun is in line with the stick, press the thumb and finger over the thread and protractor to hold it in position. Read the latitude right from the scale of the protractor.

Observations: Sighting an object near the ceiling in a corner of the room helped to familiarize the students at the beginning of this experiment with the operation of the sextant. When sighting toward the Sun along the angle of elevation, the latitude was determined.

- Questions:
1. What kind of people would most likely use a sextant? (Navigators on the sea, in the air, or in outer space use sextants to find their position so they can determine locations while sailing on the water or flying in the sky.)
 2. What is a common description for finding the latitude of the Sun? (Shooting the Sun.)

Conclusions: Latitude can be measured using a student assembled sextant.

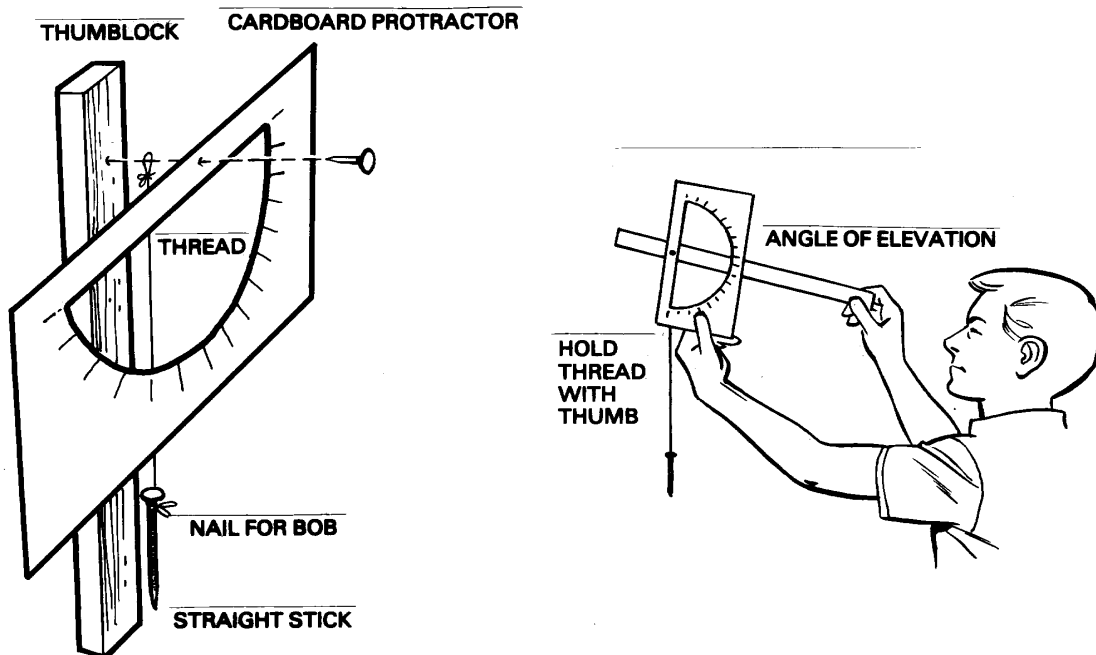

THE SEXTANT

Objective: To name the parts of a sextant and how to operate this instrument.

Materials: Diagram and direction of sextant parts.

Procedure: Background The sextant is a navigator's instrument said to have been invented by Sir Isaac Newton in 1672. It is used for measuring angles between two bodies, usually between the horizon and the sun, the stars, the planets, or the moon. The navigator uses these altitudes, along with information obtained from the nautical or air almanacs in finding his latitude and longitude.

In the famous "noon sight", which has been used for hundreds of years, the navigator "shoots" the sun at its greatest altitude at noon. Using the corrected altitude figure and declination, he finds his latitude.

Directions for use: Look at the diagram. The pilot looks through the telescope and through the unsilvered half of the horizon glass to see the horizon. Move the arm until the reflected image of the sun or star from the index mirror touches the horizon in the horizon glass. The pilot reads the angle between the horizon and the sun or star in degrees and minutes on the scale. Note: The actual divisions on the scale are one-half an angular degree in size.

In airplanes a bubble sextant is usually used. The angle is measured with reference to a horizontal plane established by a leveling bubble or pendulum device.

Observations: In the absence of a real sextant and hands-on experiences, becoming familiar with the diagram is the next best thing.

- Questions:
1. Can you name one early navigator who used a sextant for his voyages? (Columbus. The pilot of the ship couldn't figure out what was wrong because they sighted land and the old maps said there should be water at that latitude and longitude.)
 2. Why is knowledge of the sextant important to navigation in the air? (Exact locations are extremely important since planes travel so fast. Usually a "Navigator" spends all his time giving precise information to the pilot.)

Conclusions: A sextant is valuable for navigation both in the water and in the air for determining exact locations.

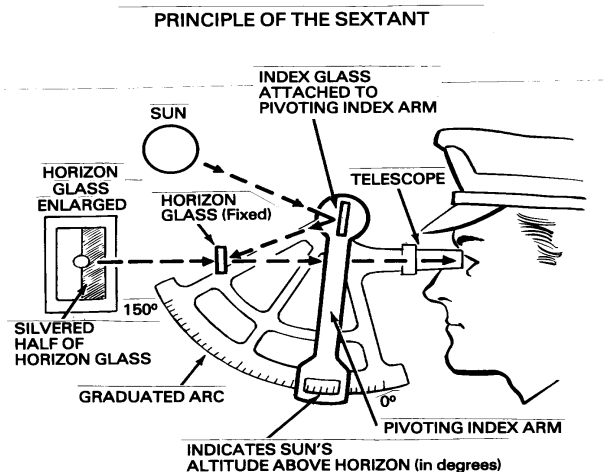

BIBLIOGRAPHY
BIBLIOGRAPHY OF SOURCES FOR THE MIDDLE GRADE EDUCATOR

Beach, L. (1991). World Class Geography, Instructor, 100(6), 27-28, 37-39.

Describes a Louisiana elementary school's multidisciplinary geography program. The class selects a destination to which they travel by imaginary plane (created in the classroom), and the teachers integrates cross-curricular skills. Students research and discuss the trip (resources, flight plans, passports, and travel logs) and write descriptive postcards and journalistic accounts.

Bonnet, R. & Keen, G. D. (1992). Space and Astronomy. Blue Ridge Summit, PA.:TAB

Advised for grades 5 through 8. Forty-nine science fair projects related to space and astronomy are proposed in this book. The projects include creating analogies to help people better understand astronomical figures and making three-dimensional models of planets.

Berliner, D. (1990). Distance Flights. Minneapolis: Lerner.

Recommended for grades 5 through 8. The historical development of flight is traced from Louis Bleriot, the first person to fly across the English Channel, to Dick Rutan and Jeanna Yeager, who in 1986 flew nonstop around the world.

Branley, F. (1990). The Christmas Sky. New York: Harper Collins.

Suggested for grades 3 to 7. Illustrations by Stephen Fieser. This book describes scientific explanations about the stellar and planetary configurations in the sky at the time of Jesus' birth.

Briggs, C.S., (1991). At the Controls: Women in Aviation Minneapolis: Lerner.

Recommended for grades 5 through 8. This book includes biographies of aviators such as Jerrie Cobb, Bonnie Tiburzi and others. The author also traces the history of modern aviation through the achievements of these female aviators.

Brown, P. L., (1990). Star and Planet Spotting: A Field Guide to the Night Sky New York: Sterling.

Grades 6-8. This book guides the reader on how to identify stars in the night sky. It tells the best time to view and what to bring when out in the field at night.

Colton, Ted. Safety in the Air: A Curriculum about Flight and Air Traffic Control Designed for Middle School Students Federal Aviation Administration, Washington, DC. 1983. ERIC, ED 248 135.

This unit of six lessons is designed to familiarize sixth, seventh, and eighth grade students with air traffic safety and the individuals who make air traffic safety possible. Each lesson consists of a statement of the concept fostered, a list of objectives, a short discussion on the focus of the unit, and instructional strategies for lesson topics and activities. The major lesson topics are: behavior and properties of air, the theory of flight and the physical properties of air that contribute to flight; the growing volume of air traffic and the necessity for air traffic control; visual flight rules; instrument flight rules, and airport terminal facilities.

DeSensi, F. & Rostoy, S. (1991). Curriculum Package: Elementary (School) Social Studies Lessons. (A visit to the Louisville. Kentucky Airports: Standiford and Bowman Fields.)ED 352307.

These lesson plans are designed for use by elementary school social studies teachers who take their classes to tour the regional airports of Louisville, Kentucky. Fifteen lesson plans are included. A bibliography is provided along with an appendix that lists organizations from which educational resources about aviation and aerospace are available.

Dye, Aimee. Aviation Curriculum Guide for Middle Grade School Level, Secondary School LevelCoalition of Indian Controlled School Boards, Inc., Denver, Colorado, 1984. ERIC, ED 248 134.

This curriculum guide consists of activities and experiences which are organized into four sections by curricular area. These areas are: Language arts (listening, speaking, and viewing; reading comprehension; media center skills); mathematics (aircraft instruments and aviation applications of mathematics); science (theory of flight and aviation applications of science); and social studies (history and growth of aviation; maps, charts, and globes; methods used in aerial navigation; changing concepts of time and space; and aviation careers). Each section includes a separate table of contents, an overview, a list of objectives, and lists of recommended activities and materials. The guide is designed especially for teachers who have had no special training in aviation education and is not intended to be used as a separate course of study in aviation. Consequently, it can most effectively be used to supplement existing curricular materials.

Eckford, Jim. "Ballooning Comes of Age: Make Your Own Balloon."Aviation/Space. 1 (Summer 1983): 72-73.

This article provides instructions for building a working model of a hot-air balloon. It offers suggestions for a successful flight, and it indicates that children can be involved in the projects.

Ethnographic Resources for Art Education Project.Play-things as Art Objects: Ideas and resources. Kites and Sound Making Objects and Playing Cards and Dolls Birmingham, Polytechnic Department of Art, Birmingham, England, 1983. ERIC, ED 249 158.

Here are five booklets on playthings as art objects. They draw together information about historical, ethnographic, and play traditions of various world cultures. The first two booklets are most relevant. Booklet one gives an overview of ideas and resources about kites, etc. The second booklet discussed the distribution and origin of kites--Japan, Korea, Guatemala, and Southeast Asia. There is a section included which related kites to science and provides songs about kites.

Forschauer, L. (ed). Teaching Elementary Science with Toys, CESE Sourcebook VII. Washington, DC.: Office of Educational Research and Improvement.

By playing with toys, children sometimes wonder how and why toys do what they do. This book presents 53 classroom-tested activities to teach science with toys.

Freeland, K. & Smith, K. (1993). "A Thematic Teaching Unit on Flight"Social Studies and Young Learner, 5, 15-17.

Presents an interdisciplinary unit on flight and space designed for the fourth grade. Describes class activities and a field trip that are integral parts of the unit. Provides suggestions for teachers wishing to create similar interdisciplinary units.

Frensch, H. (1990). Flight. Science Series Grades 4-5,6

The activities in this book are designed to reinforce the elementary concepts of flight. General background information, suggested activities, questions for discussion, and answers are provided.

Giessow, J. (1990). Exploring the Universe. Science Series Grades 4-5, 6

The activities in this book are designed to reinforce elementary concepts in the study of the universe. General background information, suggested activities, questions for discussion, and answers are provided. Twenty-eight reproducible worksheets are contained in this guide.

Gehardt, Lillian N, ed. Subject Guide to Children's Books in Print 1989-1990New York; R.R. Bowker, 1989.

Here is an annual subject index which provides educators with information about which trade books are in print, their price, and publishing information. Books on our topic may be found under these subject headings: Aeronautics; Aeronautics--Accidents; Aeronautics--Biography; Aeronautics--Commercial; Aeronautics--Flights; Aeronautics--History; Aeronautics--Military; Aeronautics--Safety Measures; Aeronautics--Vocational Guidance; Air Pilots; Aircraft; Aircraft Carriers; Airplanes; Airplanes, Military; Airplanes--Models; Airplanes--Piloting; Airships; Astronautics; Astronautics--Biography; Astronauts; Balloons; Bombers; Flight; Flying Saucers; Interplanetary Voyages; Jet Planes; Kites; Manned Space Flight; Outer Space Exploration; Pilots and Pilotage; Rocketry; Rockets(Aeronautics): Space Exploration (Astronautics); Space Flight; Space Sciences; and Space Vehicles; Space Vehicles--Models; Weather; Weather Forecasting; and Women in Aeronautics.

Gerlovich, Jack and David Fagle. "Aerospace Education: A Pilot Program." Science Teacher. 50 (May 1983): 68-69.

Here is a description of a K-12 aerospace program. The ninth-grade (pilot program) consists of history, applications (principles of flight, weather, navigation), research, and careers. The program evaluation is reported.

Greger, Margaret. "Kites in the Classroom." School Art. 84(January 1985): 18-20.

There are class-tested designs of easy to make and decorate kites. Inexpensive materials are used. One will find within this article instructions for making a Vietnamese kite.

Hatchett, Clint. (1988). The Glow-in-the-Dark Night Sky Book New York: Random.

This book is suggested for grades 2 through 5. Illustrations by Stephen Machesi. Information about star groups is presented, along with glow-in-the-dark illustrations depicting the people and animals that have given these constellations their names.

Hartsfield, John W. and Kendra J. Hartsfield. Human Spaceflight. Activities for the Primary Student Aerospace Education Services Project. National Aeronautics and Space Administration, Cleveland, Ohio, 1985. ERIC, ED 714.

This space science activity booklet was designed to provide information and learning activities for students elementary grades. It contains chapters on: primitive beliefs about flight; early fantasies of flight; the United States human spaceflight programs; a history of human spaceflight activity; life support systems for the astronaut; food for human spaceflight; clothing for space- flight and activity; waste management systems; a human space flight log; and additional activities and pictures. There is also a bibliography of books, other publications and films.

Hartsfield, J & Sellers, M. (1990). An Outline of the Solar System: Activities for the Elementary StudentCleveland, Ohio: NASA Lewis Research Center.

This booklet provides information and five worksheets for elementary students studying the solar system. Fact sheet provide information on the Sun, Mercury, Venus, Earth, Moon, Mars, asteroids, Jupiter, Saturn, Uranus, Neptune, Pluto, and comets. The worksheets are entitled: (1) Astronomical Unit; (2) Solar System Trivia; (3) Solar System Flash Cards; (4) Solar System Crossword; and (5) Solar System Word Search.

Hosking, Wayne. Flights of Imagination. An Introduction to AerodynamicsNational Science Teachers Association, Washington, DC, 1987. ERIC, ED 282 712.

This document traces some of the history of kites and provides teachers and students with basic information about kite components and flight dynamics. The major portion of the book provides students with 18 projects that deal with: shapes that will fly; kites compared with gliders; lift; air flow; the angle of attack in flying kites; measurements; the use of dihedral angles for stability; positioning kites using a tail; materials; box kites; making height readings; making wind gauges; constructing a wind vane; the study of wind; the aspect ratio of a kite; the weight to area factor; wind speed and lift; and force. The appendices contain information on materials for kites, when to fly a kite, where to fly a kite, how to fly a kite, and kite safety, along with a glossary, resource list, and a bibliography. There are also included a metric conversion chart and reproducible template for making a wind gauge and a weather vane.

Irons, C. & Irons, R. (1991). Ideas. Arithmetic Teacher, 49(2),

Presents activities for the K-2, 3-4, 5-6, and 7-8 levels focusing on the role of numbers and language in real-world situation. Students are asked to discuss, describe, read, and write about numbers they find in toy shops, the post office, in sports, and at airports. Provides appropriate worksheets.

Kelch, J. (1990). Small Worlds: Exploring the 60 Moons of Our Solar System New York: Julian Messner.

Suggested for grades 6 through 8. The author provides a description of the origin, characteristics, and discovery of the sixty moons in our solar system.

Kline, R. The Ultimate Paper Airplane

This book contains seven different models of aircraft featured on "Sixty Minutes."

Krupp, E.C., (1989). The Big Dipper and You New York: Morrow Junior Books.

Recommended for grades 3-5. Illustrations by Robin Rector Krupp. This book describes the movement of the earth and the stars and explains the components of the Big Dipper constellation. It also refers to the North Star as a guide to locate the constellation.

Lampton, C. (1988). Stars and Planets. New York: Doubleday.

Grades 2-4. Illustrated by Ron Miller. The author describes the nature of meteors, black holes, galaxies, and space explorations, and talks about the possibility of extraterrestrial life.

Mander, J., Dippel, G. & Gossage, H. The Great International Paper Airplane Book

Competition winning entries are clearly diagrammed to cut, fold and fly.

Maurer, R. (1990). Airborne: The Search for the Secret of Flight New York: Simon & Schuster.

Suggested for grades 4-8. Illustrations by Brian Lies. The author and illustrator vividly describe the development of flight from balloons and gliders to helicopters and airplanes. The text is accompanied by activities that simulate the principles of flight.

Millspaugh, B.P. (1992). Aviation and Space Science Blue Ridge Summit, PA: TAB Books.

This books includes projects dealing with air density, wind, balloons, gliders, spacecraft, and many more aviation and space related categories.

Milson, James L. "How High is Up?" Science and Children 25(April 1988): 18-20.

Milson describes how to construct a simple device that students can use to estimate how high their kites are flying as well as the heights of other objects.

National Aeronautics and Space Administration. (1991). Aviation & Space Education: A Teacher's Resource Guide Washington, DC, ERIC ED 341579.

This resource guide contains information on curriculum guides, resources for teachers, computer related programs, audio/visual presentations, model aircraft and demonstration aids, training seminars and career education, and an aerospace bibliography for the primary grades. Each entry includes all or some of the following items: title, an address and phone number, and a brief description. Topics include the history of flight and model rockets.

National Aeronautics and Space Administration. Film Catalog: John F. Kennedy Space Center Washington, DC, 1987. ERIC ED 300 277.

This is a catalog listing the titles and abstracts for over 150 films that are available from NASA on topics regarding space flight, meteorology, astronomy, NASA programs, satellites, research, safety, technology, and earth sciences. Ordering and usage information are also included. For 37 of these films, a lesson guide is provided. Each guide lists objectives, vocabulary, preparatory activities, follow up activities, evaluation ideas, related information sources, and ideas for presenting the lesson.

National Information Center for Educational Media(NICEM). Index to 35mm Educational Filmstrips 8th ed., Albuquerque, New Mexico: National Information Center for Educational Media, 1985.

Here is a three volume subject index and directory of producers/distributors with brief annotations. Other indexes available from NICEM are: Index to Educational Audio Tapes, Index to Educational Slides, and Film & Video Finder.

Look under these headings: Industrial and Technical Education(look under Aviation, General Aeronautics; Aviation, Military: Aviation, Rockets; Aviation, Space; Aviation, Structures); Earth Science (then look under Physics--Aerodynamics); and Social Science (look under Transportation--Air).

Nicholson, I. (1991). The Illustrated World of Space. New York: Simon & Schuster.

Suggested for grades 3 and up. This book covers the history of astronomy, from ancient astronomy including Stonehenge and the pyramids, to current information about the solar system such as black holes and life beyond Earth.

O'Connell, Susan M., ed. The Best Science Books & A-V Materials for Children Washington, DC: American Association for the Advancement of Science, 1988.

The annotated bibliography is divided into two sections: books and audiovisual materials consisting of films, filmstrips, and videocassettes. In the Table of Contents of the books section, look under these headings: Mathematics and Physical Sciences (then look under Earth Sciences--Meteorology, Climatology, Atmosphere. Under the heading, Engineering, look under Transportation- Aerodynamics; air-craft types, aviators, aeronautics and astronauts). In the Table of contents of the A-V Materials, also look under Earth Sciences and Engineering-- Aerospace Engineering.

Oklahoma Curriculum Improvement Commission High Flight: Aerospace Activities, K-12 Oklahoma State Department of Education, Oklahoma City, 1982. ERIC ED 222 345.

Within this document are discussions of Oklahoma aerospace history, the history of flight, and the interdisciplinary aerospace activities. Each activity includes the concept, purpose, list of necessary materials, and

procedures. Topics include planets, the solar system, rockets, airplanes, air travel, space exploration, principles of flight, kites, air motion/pressure, satellites, and others. Activities include: vocabulary exercises, word searches, crossword puzzles, simple science experiments, various art and mathematics activities. Also included are key words, a list of instructional aids, and an evaluation sheet.

Pilger, Mary Anne. Science Experiments Index for Young People Englewood, Colorado: Libraries Unlimited, 1988.

Here is a guide to experiments and activities which are available in elementary and intermediate science books. The experiments run from the very easy to the more difficult. Begin by looking in the index for these subjects: Aerodynamics, Air, Airplanes, Flight, Gliders, Gravity, Kites, Rockets, Space Science, Space Travel, and Spacecraft. Then note the book entry number and page number(s). Turn to the back of the book entitled "Books Indexed." Here you will find the book citation by entry number.

Porcellino, M. (1991). Young Astronomer's Guide to the Night Sky Blue Ridge Summit, PA.: TAB.

Recommended for grades 5 and up. This book is a good reference for young astronomers. It gives the reader a guide to locate constellations, identify stars, know when to look for meteor showers, and observe the changing phases of the moon. It also tells the readers how to join amateur astronomy clubs throughout the country.

Saterstrom, Mary H., ed. Educators Guide to Free Science Materials 30th ed. Randolph, Wisconsin: Educators Progress Service, 1989.

This is an annual annotated index which is very helpful for finding 16mm films, filmstrips, slides, audiotapes, and printed materials. Aerospace education materials are found only in the sections listing 16mm films and printed materials. Although the guide is not free, educators will find a gold mine of material which is. Subjects which will locate the most information on this subject are: Aerial Combat; Aerial Defense; Aerobatics; Aerodynamics; Aerospace Education; Air Combat; Aircraft Carriers; Aircraft Design; Aircraft History; Aircraft Industry; Aircraft Maintenance, Aircraft Rescue; Aircraft Safety; Aircraft Testing; Air Defense; Air Demonstrations; Air Force; Air Masses; Airplanes, Model; Air Navigation; Airports; Air Shows; Air Traffic; Air Traffic Control; Air Transportation; Apollo; Astronauts and Astronautics; Aviation, Model; Flight Safety; Flight Testing; Flying Boats; Gyroscopes; Jetliner; Missile Development; Missiles and Missile Testing, Missile Sites, Moon Flights; NASA; National Airspace System; Naval Aviation; Navy; Pilots and Piloting; Polar Flights; Radar; Rockets and Rocketry; Satellites; Spacecraft; Space Entry and Re-Entry; Space Exploration and Research; Space Flight; Spacelab; Space Launches, Space Medicine, Space Navigation; Spaceport; Space Programs; Space Science; Space Shuttle; Space Technology, Space Transportation, Space Walk; Test Pilots; Thunderbirds; Weather and Weather Forecasting; and Weightlessness.

Scarnati, J.T. (1992). The Hooley Machine, Science Activities 29(2), 30-35.

Describes how students can make and use Hooley Machines to learn how mechanical energy can be transferred from one object to another within a system. The Hooley Machine is made using a pencil, eight thumbtacks, one pushpin, tape, scissors, graph paper, and a plastic lid.

Schaff, F. (1990). Seeing the Sky: 100 Projects Activities and Explorations in Astronomy New York: Wiley.

Advised for grades 4 and up. These hands-on activities and science fair projects are related to astronomy. The book offers ideas on how to set up experiments and design projects about the planets, stars, and constellations. It provides good illustrations on how to use telescopes, binoculars, and other tools of astronomy.

Schatz, D. (1991). Astronomy Activity Book New York: Simon & Schuster.

Recommended for grades 3- 5. Drawings by Roy Doty. This book is divided into five sections: moon, sun, stars, planets, and meteors. Included in each section are suggested hands-on activities.

Schkenker, R. (1990). "Why Kites Fly. Teacher Background for DSO for DoDDS Japan Day with Kites." ED326395.

This paper discusses the physical principles behind the flying ability of both kites and airplanes. This background material was developed for a program in which a Japanese kite maker conducts kite making and flying classes in the Japan School District Elementary Schools of the Department of Defense Dependents Schools (DoDDS), Pacific Region. The two principles critical to understanding of Newton's Law and Bernoulli's Principle. While other factors such as the friction between the air particles moving over the flying surface and the material comprising the flying surface are important, these two factors explain the major components of lift and therefore the major reasons kites fly.

Schmidt, N. Discover Aerodynamics with Paper Airplanes

Activities and reproducible plans for building paper airplanes make principles of flight real.

Simon, S. (1986). Stars. New York : Morrow Junior Books.

Grades 3-6. From the birth of a star to the death of a supernova, this book describes with clarity the composition and life cycles of stars.

Simon, S. (1988). Galaxies. New York: Morrow Junior Books.

Suggested for grades 3-6. This book describes the origin and existence of spiral and elliptical galaxies that whirl through space.

Simon, S. (1991). Neptune. New York: Morrow Junior Books.

Recommended for grades K through 5. Illustrated with color photographs. The text describes new discoveries about Neptune as Voyager 2 passed through its orbit.

Sneider, Cary and others. "Learning to Control Variables With Model Rockets: A New-Piagetian Study of Learning in Field Settings." Science Education 68(July 1984): 465-486.

Here is a report on the testing of the effectiveness of a program designed to teach young people how to conduct and interpret a controlled experiment. The results show that the ability to control variables can be taught using the program of activities related to designing, building, and launching model rockets.

Spitzer, Michael. "Tie Your Lesson to a Kite." Outdoor-Communicator 13(Fall 1982): 15-18.

Spitzer describes kites and kite flying in different countries and throughout history. He notes that the same principles govern kite behavior and the flight of airplanes.

Strickler, Mervin K., Jr. Guidelines for Federal Aviation Administration Regional Aviation Education Coordinators and Aviation Education Facilitators Federal Aviation Administration, Washington, DC, 1983. ERIC ED 247 118.

Information in this document is on the history of aerospace/aviation education, FAA educational materials, aerospace/aviation curricula, FAA responses to requests from schools and colleges, etc. In the appendices there is additional information which includes: the scope of aerospace education; a list of aerospace course opportunities in various subject areas; a guide to FAA aviation education supplementary materials (listing materials by curricular areas for primary, intermediate grade, and junior high school levels; and a list of FAA, CAP, and National Aeronautics and Space Administration regional offices).

Stine, G.H. Handbook of Model Rocketry 6th edition

This revised and updated editions of model rocketeer's "bible" show how to safely build, launch, track, and recover model rockets- and have fun doing it.

Strongin, H. & Others. Science on a Shoestring 2nd edition

Often elementary and junior high teachers search for effective, inexpensive, and easy-to-understand science activities. This document was designed with those teachers and their students in mind. It provides hands-on science activities that focus around three components: (1) themes broad, unifying ideas that pervade science, math and technology; (2) processes-- the techniques used to develop and test scientific concepts; and (3) concepts-- including the vocabulary and the key information children need to develop and communicate scientific ideas. Over 45 activities related to matter, change, and energy are presented.

Turner, Thomas N. "Flight-of Fancy: Teaching the Lure and Love of Flight to Elementary School Students."Social Studies 79(January-February 1988): 37-38.

This article describes how the history of flight can be used to encourage elementary school children to read, discuss, and do research on an aviation topic. It outlines several activities that can be used to encourage student interest.

Vogt, G. (1992). Rockets: A Teaching Guide for an Elementary Science Unit on RocketryWashington, DC.: National Aeronautics and Space Administration.

Utilizing simple and inexpensive equipment, elementary and middle school science teachers can conduct interesting, exciting, and productive units on rockets. This teaching guide includes a brief history of rockets, Newton's law of motion, many activities, and a list of commercial suppliers of model rocketry.

The journal articles and ERIC documents have been located via the Silver Platter Compact Disk Program 1983-September, 1995.

VIDEOS

AVIATION

Freedman, R. (1992). The Wright Brothers: How They Invented The Airplane [Videocassette]. American School Pubs. SRA School Group.

This is an informative biography of how the Wright brothers, Orville and Wilbur took to the sky.

Holiday Video Library. The History of Flight Video [Videocassette].

An hour presentation of the first flying machines to the sophisticated space shuttle. Students relive the excitement of these amazing inventions.

National Free Flight Society. (1993). The Joy of Flying Free [Videocassette].

In this video, the hobby of flying scale model aircraft is introduced with participants describing their experiences.

Westmoreland, N. (Producer & Director). (1994). Cleared to Land. [Videocassette]. Westmoreland Productions.

This hour video comes highly recommended from the Video Rating Guide for Libraries. What makes this especially captivating is the creative use of film and music to narrate the experience of flight. Suggested for Pre-Kindergarten to Primary.

JUVENILE LITERATURE

Aaseng, N. (1992). Breaking the Sound Barrier. New York: J. Messner.

Chronicles the events leading up to the breaking of the sound barrier, focusing on the test pilots who risked their lives to achieve supersonic flight.

Bendick, J. (1992). Eureka! It's an airplane!. Brookfield, Conn.: Milbrook Press.

Describes the development of the airplane and some of the inventions that have made it a more common means of transportation.

Berliner, D. (1990). Before the Wright Brothers. Minneapolis: Lerner.

Berliner, D. (1990). Distance Flights. Minneapolis: Lerner.

Recommended for grades 5 through 8. The historical development of flight is traced from Louis Bleriot, the first person to fly across the English Channel, to Dick Rutan and Jeanna Yeager, who in 1986 flew nonstop around the world.

Blackman, S. (1993). Planes and Flight. New York: F. Watts.

Describes some of the different devices, including hot air balloons, gliders, airplanes, and jets, used to get people into the air. Includes various projects.

Branley, F. (1991). The Big Dipper. New York: Harper Collins.

Burleigh, R. (1991). Flight: The Journey of Charles Lindbergh. New York: Philomel.

Coerr, E. (1992). The Big Balloon Race. New York: Colliers.

Freedman, R. (1991). The Wright Brothers: How they invented the Airplane

Follows the lives of the Wright brothers and describes how they developed the first airplane.

Gallant, R. (1991). The Constellations: How They Came to Be. New York: Four Winds.

Gunning, T. G. (1992). Dream Planes. New York: Dillon Press. Describes some recent advances and future technological possibilities in the field of air transportation.

Haynes, R. M. (1991). The Wright Brothers. Englewood Cliffs, NJ: Silver Burdett Press.

Traces the lives of the Wright brothers and describes how they showed the world how to fly.

Jennings, T.J. (1993). How Flying Machines Work. New York: Kingfisher Books.

Examines, in text, labelled diagrams, and illustrations, how various types of airplanes and other flying machines work and the kinds of functions they perform. Includes instructions for related projects and experiments.

Jeunesse, G. & Verdet, J.P. (1992). The Earth and the Sky. New York: Scholastic.

Lindlelom, S. (1991). Fly the Hot Ones. Boston: Houghton Mifflin.

Maynard, C. (1993) I wonder why planes have wings and other questions about transport. New York: Kingfisher Books.

Answers questions about transportation and vehicles, including "Do airships run on air?" and "Why don't ships sink?"

Nahum, A. (1990). Flying Machine New York: Knopf.

A photo essay tracing the history and development of aircraft from hot-air balloons to jetliners. Includes information on the principles of flight and the inner workings of various flying machines.

Pearl, L. (1994). The Story of Flight Mahwah, N.J.: Troll Associates.

Surveys the history of aviation, from the first attempts to modern supersonic planes.

Robson, P. (1992). Air, Wind & Flight New York: Gloucester Press.

Schulz, W. A. (1991). Will and Orv. Minneapolis: Carolrhoda Books.

Taylor, J.W.R. (1990). The Lore of Flight New York: Mallard Press.

Taylor, R.L. (1993). The First Flight Across the United States: The Story of Calbraith Perry Rodgers and his airplane, the Vin Fiz. New York: F. Watts.

A biography of the pioneering aviator, trained by the Wright brothers, who completed the first flight across the United States in 1911.

Wade, M. (1992). Amelia Earhart: Flying for Adventure. Brookfield, CT.: Millbrook.

Welch, B. (1992). The Wright Brothers: Conquering the Sky. New York: Fawcett Columbine.

Wood, T. (1993). Air Travel. New York: Thomson Learning.

Discusses the development and different parts of aircraft, how air traffic is controlled, and the effects of air transport on the world.

Kits

The various kits available through Delta Education: The Middle School Catalog, Nashua NH phone 1-800-442-5444.

Whitewings Collection Series

This kit includes 15 cut-and-paste gliders.

These Kits and supplies are available through Pitsco, Pittsburg, KS phone 1-800-835-0686

Or Kits and Supplies available through

American Science & Surplus

Delta Education

Estes

Pitsco

Juvenile Literature

----- (1992). *The Visual Dictionary of Flight*. New York: Dorling Kindersley.

GOVERNMENT RESOURCES

The Eisenhower National Clearinghouse is to:

encourage the adoption and use of k-12 curriculum materials and programs which support national goals to improve teaching and learning in mathematics and science by providing better access to resources for all who are interested in creating an effective learning environment.

The Clearinghouse will accomplish this by:

creating and maintaining a comprehensive, multi-media collection of materials and programs which will be distributed in a timely manner through a national system using both traditional formats and advanced computing and telecommunications technologies.

Federal Aviation Administration. (1994). *Guide to Federal Aviation Administration Publications*. Washington, DC: U.S. Department of Transportation. A helpful guide to current FAA publications.

GLOSSARY VOCABULARY WORDS

Aerodynamics Study of the forces of air acting on objects in motion relative to air.

Air A mixture of gases making up the atmosphere which surrounds the earth.

Airfoil A streamlined surface designed in such a way that air flowing around it produces useful motion.

Airplane A mechanically-driven, fixed-wing, heavier-than-air craft.

Airport A tract of land or water for the landing and takeoff of aircraft. Facilities for shelter, supply and repair are usually found there.

Airspeed Speed of the aircraft relative to the air through which it is moving.

Airway An air route marked by aids to air navigation such as beacons, radio ranges and direction-finding equipment, and along which airports are located.

Altimeter An instrument for measuring in feet the height of the airplane above sea level.

Altitude The vertical distance from a given level (sea level) to an aircraft in flight.

Anemometer Instrument to measure speed of wind.

Ascent Climb.

Atmosphere Blanket of air surrounding the earth.

Aviation A term applied to all phases of the manufacture and operation of aircraft.

Barometer An instrument to measure pressure of the atmosphere.

Beacon A light or other signal indicating direction.

Ceiling Height above ground of cloud bases.

Chart An aeronautical map showing information of use to the pilot in going from one place to another.

Cirrus Type of high thin cloud.

Compass An instrument indicating direction.

Control Tower A glassed-in observation tower on the airport from which control tower operators observe and direct airport air and ground traffic.

Course The direction over the earth's surface that an airplane is intended to travel.

Crosswind Wind blowing from the side, not coinciding with the path of flight.

Cumulus Type of cloud formed in puffs or dome-shaped.

Current Stream of air.

Degree 1/360 of a circle, or 1/90 of a right angle.

Dive A steep angle of descent.

Drift Deviation from a course caused by cross-wise currents of air.

Elevation The height above sea level of a given land prominence, such as airports, mountains, etc.

Flaps Hinged or pivoted airfoil forming part of the trailing edge of the wing and used to increase lift at reduced airspeeds.

Flight Plan A formal written plan of flight showing route, time enroute, points of departure and destination, and other pertinent information.

Force A push or pull exerted on an object.

Freight Cargo.

Front (Weather) Boundary of two overlapping air masses. When cold air is advancing on warm air, it is said to be a cold front; warm air advancing on cooler air is a warm front.

Glide A motion of the airplane where the airplane descends at an angle to the earth's surface.

Glider A fixed wing, heavier-than-air craft having no engine.

Gravity Force toward the center of the earth.

Hail Lumps or balls of ice falling to the earth out of thunderstorms.

Hangar Building on the airport in which airplanes are sheltered or stored.

High Pressure Area Mass of air characterized by high barometric pressure.\

Horizontal Parallel to the horizon.

Humidity Amount of invisible moisture in a given mass of air.

Knot A measure of speed, one knot being one nautical mile per hour.

Landing Pattern A set rectangular path around the airport which airplanes follow to land.

Lift An upward force caused by the rush of air over the wings, supporting the airplane in flight.

Low Pressure Area Mass of air having low atmospheric pressure.

Meteorology The scientific study of the atmosphere.

Moisture Water in some form in the atmosphere.

Parachute A fabric device attached to objects or persons to reduce the speed of descent.

Pedals Foot controls in the cockpit by which the pilot controls the action of the rudder.

Pilot Person who controls the airplane.

Pressure Force in terms of force per unit area.

Precipitation Any falling visible moisture; rain, snow, sleet, hail.

Radar Beamed radio waves for detecting and locating objects. The objects are "seen" on the radar screen, or scope.

Stationary Something that does not move is said to be stationary. A front along which one air mass does not replace another.

Stratus Layered clouds.

Streamline An object shaped to make air flow smoothly around it.

Thrust Forward force.

Transmitter Microphone, or part of the radio that sends the message.

Turbulence Irregular motion of air; uneven currents of air.

Updraft Vertical currents of air.

Velocity Speed.

Vertical Ninety degrees from the horizon.

Visibility Distance toward the horizon that objects can be seen and recognized. Smoke, haze, fog, and precipitation can hinder visibility.

Vortex A circular, whirling movement of air forming a space in the center toward which anything caught in the vortex tends to move.

Weather Condition of the atmosphere at a given time with respect to air motion, moisture, temperature, and air pressure.

Wind Air in motion, important in aviation because it influences flight to a certain degree.

How to Get Ahead When Things Keep Changing!

FEDIX/MOLIS

On-Line Access

FEDERAL GOVERNMENT INFORMATION AND MINORITY INSTITUTIONS

*Access via Modem or Internet * Free User's Guide * No Registration Fees*

FEDIX (Federal Agency)

- research programs
- education programs
- program contacts
- free equipment
- procurement notices
- educational scholarships and fellowships

MOLIS (Minority Institutions)

- institutional research capabilities
- Faculty profiles
- contact information
- degrees and enrollments by department

Participating Agencies

- DOE
- AID
- EPA
- DOT
- NASA
- AFOSR
- VA
- ILTO
- NIH
- ONR
- USDA
- DISA

Modem Lines

(301)258-0953 DC Metro Area
(800)783-3349 Toll-Free for Minority Institutions Only

INTERNET Address

fedix.fie.com

World Wide Web

URL: <http://web.fie.com/>

Available:

24-Hours a Day, 7 Days

Modem Setup

8 Databits, NO Parity, 1 Stopbit

NIH!!

**National Institutes of Health
NOW on FEDIX/MOLIS
NIAID, NIEHS, NCI and Other Institutes**

Federal Information Exchange, Inc.

555 Quince Orchard Road, Suite 360, Gaithersburg, MD 20878
(301)975-0103 Phone (301)975-0109 Fax